

PROCHEM®

Fivestar & Comet

UPRIGHT CARPET SOIL EXTRACTOR



SAFETY, OPERATION & MAINTENANCE INSTRUCTIONS

MODELS: TR300 FIVESTAR
TR419 COMET

- **CAUTION – READ THE INSTRUCTION MANUAL BEFORE USING THE APPLIANCE**
- **ORIGINAL INSTRUCTIONS**
- **MANUAL ALSO AVAILABLE ON LINE AT WWW.PROCHEM.CO.UK**

CE

MACHINE DATA

MODEL NO.	
SERIAL NO.	
DATE OF PURCHASE	
DISTRIBUTOR NAME	
DISTRIBUTOR TEL NO.	
MANUFACTURER CONTACT	Prochem Europe Ltd. Oakcroft Road, Chessington, Surrey KT9 1RH, UK Telephone: + 44 (0)20 8974 1515 Fax: + 44 (0)20 8974 1511 Email: sales@prochem.co.uk Website: www.prochem.co.uk

All information and specifications in this manual are current at the date of issue. However, because of Prochem Europe policy of continual product improvement, we reserve the right to make changes at any time without notice. Please note that this manual applies to all models and explains variations including accessories used. Therefore, you may find some explanations for variations and options not installed on your equipment.

CONTENTS

	PAGE NO.
WARRANTY	5
WARNING SECTION	6
IMPORTANT SAFETY INSTRUCTIONS	7
GENERAL DESCRIPTION OF APPLIANCE & IMPORTANT OPERATING INSTRUCTIONS	8
GENERAL OPERATING INSTRUCTIONS	9
PRACTICAL CLEANING	10
ACCESSORIES & CHEMICALS	13
GENERAL MAINTENANCE	14
GENERAL FAULT FINDING	16
MACHINE PARTS LIST	17
PUMP PARTS LIST	23
HAND TOOL PARTS LIST	24
WIRING DIAGRAM	25
CE DECLARATION OF CONFORMITY	27



This product is marked according to the **European Directive (2002/96/EC) on Waste Electrical and Electronic Equipment (WEEE)**.

The symbol on this product indicates that this product must not be disposed of with normal household waste. Please protect human health and the environment by disposing of this product responsibly in the correct manner.

For further information regarding the disposal, treatment, recycling and recovery of this product, please contact:

Prochem Europe Sales Department
Telephone: +44 (0)20 8974 1515

Prochem Europe Ltd. EEE Producer Registration Number: WEE / AJ0044SY

European Directive (2015/863/EU) Restriction of use of certain Hazardous Substances in Electrical and Electronic Equipment (RoHS2).

This equipment does not contain more than the maximum permitted levels by weight of the following substances:

Lead (Pb), Mercury (Hg), Cadmium (Cd), Hexavalent Chromium (Cr (VI)), Polybrominated Biphenyls (PBB), Polybrominated Diphenyl Ethers (PBDE)



MACHINE WARRANTY

DATE EFFECTIVE: 1/7/15

As of the above date, this warranty supersedes all previous warranties and forms part of the contract of sale. Prochem Europe Ltd. (hereafter referred to as "Prochem") guarantees this machine to be free from defects in materials and workmanship for the relevant time period as shown below, and from the actual date of purchase by the user. Proof of the purchase date from a Prochem Authorised Distributor will be required for performance of this warranty.

Rotationally moulded polyethylene tanks2 Years
All other parts except maintenance items (see below)1 Year

THIS WARRANTY EXCLUDES NORMAL MAINTENANCE ITEMS, including but not limited to HOSES, FILTERS, O-RINGS, DIAPHRAGMS, VALVES, DRIVE BELTS, GASKETS, CARBON BRUSHES and damage to motors and other components as a result of failure to replace normal maintenance items. THIS LIST IS NOT EXHAUSTIVE.

To obtain performance of this warranty, contact the Prochem Authorised Distributor who supplied the product.

The Prochem Authorised Distributor is responsible as the selling agent for the provision of initial training in the correct use and application of the machine and approved chemicals. The distributor is also responsible for service maintenance and repairs during and after the warranty period and the administration of any warranty claims in conjunction with the Prochem Service Department. Failure of any of these provisions and responsibilities may invalidate the warranty and the authorised status of the distributor.

If Prochem receives notice of any defects during the warranty period, Prochem reserves the right to either repair, or replace components that prove to be defective. Goods must be returned before the warranty is approved. Goods sent out prior to the return of faulty items will be invoiced at current prices, subject to standard payment terms (see Prochem Standard Terms and Conditions of Sale). Replacement parts supplied under warranty will be guaranteed for the remainder of the original machine warranty and **NOT** from the date of installation. Spare parts supplied after expiry of machine warranty may be covered by a manufacturer's warranty, subject to inspection by Prochem Europe Ltd. and at its sole discretion. Normal maintenance items, however, are not covered. Replacement or credit of any returned parts will be at the discretion of the Prochem Service Department. Any subsequent refusal to accept their decision will serve to invalidate this warranty with immediate effect.

PROCHEM AUTHORISED DISTRIBUTORS are responsible for machine and accessories service back up during and after the warranty period. Prochem will furnish parts if the warranty is approved, but **DISTRIBUTORS** will be responsible for fitting, service, labour and related charges including travel, if applicable, and the cost of returning the machine or parts to Prochem. If any chargeable work is undertaken by Prochem for **DISTRIBUTORS** the labour, parts (if applicable) and return carriage will be charged at **FULL LIST PRICE**. If warranty is approved due to genuine manufacturing defect, then labour charges and carriage charges may be waived at Prochem's discretion.

Prochem may send replacement parts to customers supplied by a **DISTRIBUTOR** or directly by Prochem, subject to the same conditions of replacement and payment above. The customer, however, will be responsible for fitting, labour and the carriage costs of returning repaired parts. Alternatively, Prochem will undertake warranty work at Chessington, subject to the same conditions, but the customer will be responsible for all carriage charges.

Any of the following circumstances involving the machine will serve to invalidate this warranty:-
NORMAL WEAR, ACCIDENTS, USE OF THE MACHINE FOR A PURPOSE OTHER THAN THAT FOR WHICH IT WAS INTENDED, INCORRECT MAINTENANCE, THE USE OF CHEMICALS OTHER THAN THOSE SUPPLIED OR APPROVED BY PROCHEM, INCORRECT INSUFFICIENT OR NON-USE OF DEFOAMER, EXPOSURE TO EXTREME TEMPERATURES OR CONDITIONS, INCORRECT INSTALLATION OR REPAIR & UNAUTHORISED INTERVENTION.

Liability is excluded for the following:-
All forms of damage and special damage founded in tort (apart from death and personal injury) and contract law including but not limited to consequential loss, loss of income and losses incurred in reliance of the contract; service, labour or third party charges and the cost of returning the machine or defective parts to Prochem or Prochem's Authorised Distributor.
As against a person dealing as a consumer, this warranty creates specific rights in addition to any statutory rights, which are unaffected. As against a person dealing otherwise than as a consumer, however, this warranty excludes any implied term that the machine will correspond with a description or a product sample.
With the exception of some specific products which are labelled and intended to be used by a consumer, all equipment, machinery, accessories, products, services and advice supplied by Prochem is intended for professional and industrial use only.

Your Prochem unit is designed to give you many years of reliable service. If a problem should arise during or after the warranty period, contact the Prochem Authorised Distributor or the Prochem Service Department, for details of the services available. Only the original purchaser of the new equipment may seek performance of this warranty – these rights cannot be transferred to a third party.

Prochem Europe Ltd.
Oakcroft Road, Chessington, Surrey KT9 1RH, ENGLAND
Telephone: + 44 (0)20 8974 1515 Fax: + 44 (0)20 8974 1511

Machine Warranty Issue 10 1/7/15

WARNING!

- **Warning!**
Machines shall not be used by children. Children should be supervised to ensure that they do not play with the appliance. This machine can be used by people with reduced physical, sensory or mental capabilities or lack of experience and knowledge if they have been given supervision or instruction concerning the use of the machine in a safe way and understand the hazards involved.
- **Caution** this machine is for indoor use only.
- **Caution** this machine shall be stored indoors only.
- **Warning!**
This machine must be disconnected from the mains during cleaning or maintenance, when replacing any parts or converting the machine to another function.
- **Warning!**
Do not allow the power cord to come into contact with the rotating brush.
- **Caution** under no circumstances should the machine be carried by or bumped up a flight of stairs using the handle, always empty the bucket before storage or transporting the machine.

IMPORTANT SAFETY INSTRUCTIONS

**PLEASE READ THE FOLLOWING IMPORTANT SAFETY INSTRUCTIONS (!!)
BEFORE ATTEMPTING TO USE THIS MACHINE. FAILURE TO OBSERVE THE
INSTRUCTIONS MAY RESULT IN PERSONAL INJURY.**

!! CAUTION

Read the instruction manual before using the appliance.

!! SOUND PRESSURE LEVEL

The sound pressure of this machine, when in use, does not exceed 85 dB (A).

!! APPLIANCE SUITABILITY

This appliance is suitable for commercial use, for example, in hotels, schools, hospitals, factories, shops, offices and rental businesses.

!! FOR MAINS POWERED APPLIANCES during cleaning and maintenance – the plug is to be removed from the outlet socket.

!! TRAINING

You must be trained in the operation of this machine before use. Please read this manual carefully and obtain operating instruction from your Prochem Distributor or authorised representative in the correct use of this equipment and suitable chemicals before attempting to clean.

!! REPAIRS

Should any repairs, including supply cord replacement be required, we recommend that the appliance be returned to an authorised dealer.

!! ELECTRICAL CABLE INSPECTION & REPLACEMENT

This machine must be earthed while in use to protect the operator from electric shock. It is equipped with a sealed and approved EC three conductor cable and three-prong 13A plug. If the supply cord is damaged it must be replaced by a special cord or assembly available from the manufacturer or its service agent. During operation a hazard may occur when running the machine over the power supply cord. The power supply cord should be regularly inspected for signs of damage. If the power supply cord is damaged, it must be replaced.

!! EXTENSION CABLES

Avoid using extension cables with this machine. If an extension cable is used it should be of a suitable rating and no longer than 30 metres. Use only three wire CE approved extension cable with CE approved three-prong earthed plugs and three pole receptacles that accept the machine 13 amp plug.

!! DO NOT pull the machine by the power cable or hoses and do not handle the plug or appliance with wet hands.

!! RCD CIRCUIT BREAKER

In common with other household and commercial electrical equipment, an 'RCD' circuit breaker plug device is strongly recommended for this type of equipment.

!! DO NOT use a multiple adaptor socket to connect the machine and heating units or other devices to a single extension cable.

!! DO NOT stand the machine in water to operate such as during flood extraction. **SERIOUS INJURY OR DEATH MAY RESULT IF MACHINE IS IMMERSSED IN WATER!**

!! DO NOT use this machine with or near flammable vapours. These machines can ignite flammable vapours such as fuels, solvents or thinners.

!! DO NOT operate the machine unless it is completely assembled.

!! DO NOT attempt repairs or maintenance unless you are suitably qualified or experienced. Repairs and maintenance should only be performed by qualified personnel and the machine should be tested for electrical safety before re-use.

!! SPRAY LIQUID ejection could be hazardous as a result of its temperature, pressure or chemical content.

!! IF FOAM or liquid comes from the exhaust switch off immediately.

!! ALWAYS disconnect machine from mains supply when left unattended, when emptying the waste container or cleaning the appliance.

!! WHEN CLEANING THE WASTE BUCKET use a broad spectrum disinfectant cleaning agent to prevent contamination from any infectious material.

!! MOVING PARTS

Keep hair, loose clothing, fingers and all body parts away from openings and moving parts.

!! CLEANING STAIRS

Use extra care when using this machine in conjunction with extension hoses to clean stairs. Ensure the machine is in a firm and stable position at the foot of the stairs. Do not position machine at top of stairs.

GENERAL DESCRIPTION OF APPLIANCE

The Fivestar and Comet machines are Hot Water Spray Extraction Machines that incorporate a rotating agitation brush to aid with cleaning.

The Machines have a clean solution bucket that also incorporates a waste solution bladder for the collection of dirty water.

The machines can also be fitted with various accessories to convert the machine to upholstery cleaning unit or a small area wand type cleaning unit.

IMPORTANT OPERATING INSTRUCTIONS

PLEASE READ THE FOLLOWING IMPORTANT OPERATING INSTRUCTIONS (!) BEFORE ATTEMPTING TO USE THIS MACHINE. FAILURE TO OBSERVE THE INSTRUCTIONS MAY RESULT IN DAMAGE TO THE EQUIPMENT.

! DO NOT expose the machine to rain or freezing temperatures. Drain solution system and store indoors when not in use.

! DO NOT operate the machine without solution and waste tank filters.

! DO NOT use boiling water or temperature in excess of 71°C.

! DO NOT use chemicals in the machine other than those manufactured or recommended by Prochem Europe.

! DO NOT use the machine for dry vacuuming. The vacuum must only be used for wet extraction in conjunction with the spray system.

! DO NOT run the solution pump dry. Always switch off and disconnect the machine when re-filling with solution.

! ALWAYS use a clean bucket to fill the solution tank.

! AFTER USE flush solution system and rinse the waste tank with clean water and remove loose fibres from the vacuum filter.

! ALWAYS observe directions and safety precautions on chemical products.

! ALWAYS pre-test surface to be cleaned for colour fastness and suitability with ready-to-use cleaning solution before proceeding.

! ALWAYS use defoamer in the waste tank to control foaming from previous shampoo residues in the carpet.

! USE ONLY genuine replacement parts for this machine, supplied by an authorised Prochem Distributor.

! DO NOT use this machine for any purpose other than for its intended design function. Any deviation from its proper use or purpose and any consequential damage that may occur is the sole responsibility of the user.

! ALWAYS discharge soiled solution to a sewage drain linked to a sewage treatment facility.

! DO NOT discharge soiled solution into roadside storm drains.

! DO NOT put any object into openings. Do not use with any opening blocked; keep free of dust, lint, hair and anything that may reduce airflow.

! DO NOT pick up anything that is burning or smoking, such as cigarettes, matches or hot ashes.

GENERAL OPERATING INSTRUCTIONS

BEFORE OPERATING THE MACHINE

Read the manual carefully and completely before attempting to operate the unit. This manual has important information for the use and safe operation of the machine and should be kept available at all times. This machine will ensure years of satisfactory service if operated and maintained according to recommendations in this manual. If additional help or information is needed, please contact your distributor or Prochem.

Prochem carpet soil extraction machines have been designed with the operator in mind. Provided you read the instructions relating to the care of your machine and follow them carefully and take advantage of the helpful hints and advice that we have passed on, you will achieve excellent cleaning results and very quickly pay for your investment. A detailed operational guide is given in the following sections, however, the following important points must be emphasised.

FAILURE TO OBSERVE THESE INSTRUCTIONS MAY SERIOUSLY AFFECT THE PERFORMANCE OF THE MACHINE AND INVALIDATE THE WARRANTY

- Connection instructions - The 220 - 240V AC models have been fitted with the appropriate EC type sealed power cable and 3 prong 13 amp plug for the UK market. Ensure the machine is connected to a 13 amp socket outlet having the same configuration as the plug. No adapter should be used with this machine. Any modification to the plug type may be dangerous and will void the warranty.
- This equipment is intended for commercial use only.
- This machine is designed for use on carpet and upholstery extraction applications and hard floor surfaces (Fivestar model only) as per instructions and recommendations written in this manual. Any deviation from its proper use or purpose and the consequential damage that may occur is the sole responsibility of the end user.
- Disconnect the power cord from outlet before servicing. Do not leave machine connected to an electrical outlet when unattended.
- Do not immerse or use this machine in standing water. Such use may cause electric shock.
- This equipment is not designed to handle or use combustible/volatile substances such as gasoline or kerosene, in, on, or near the machine. The use of such materials will cause an extreme hazardous condition.
- Use defoamer at all times to prevent damage to the vacuum motor(s).
- Do not use water in excess of 160°F (71°C).
- To prevent seal damage and chemical build-up to the pump system, run clean water through the solution lines after each use.
- All repairs must be carried out by an authorised Prochem distributor.
- Repairs should only be carried out by a qualified person.
- Do not use replacement parts other than genuine manufacturer's parts as specified in the parts list.
- Do not use chemicals in the machine other than those supplied or approved by Prochem Europe limited.
- Do not use the machine as a 'dry' vacuum. Always pre-vacuum carpets thoroughly with a separate 'dry' vacuum cleaner.
- Keep the solution tank and filter clean. Always use a clean bucket to fill the solution tank or fill direct from water supply.
- Clean the waste bucket and vacuum filter daily. Do not attempt to re-fill the solution tank before emptying the waste bucket.
- After use, flush through the pump, solution lines and waste tank with at least two litres of hot water (Do not use water in excess of 71°C).
- Do not allow the machine, hoses or tools to freeze. Freezing may seriously damage the pump and fittings. Always drain solution and store indoors when not in use. When in transit during freezing weather, insulate and cover machine, wand and hoses. To prevent hose cuffs splitting in cold conditions, immerse them in warm water before use.

PRACTICAL CLEANING

CLEANING TIPS & PREPARATION

CHECKING THE FITTING AND CONDITION

Check the condition of the area to be cleaned. Look for loose carpet, heavily soiled areas, stains or spots and worn areas. Bring these to the attention of the person in charge before proceeding. Make sure all edges of the carpet are secured or tacked in place and all seams are sewn or glued tight. This is your protection against shrinkage.

IDENTIFY CARPET AND FIBRE TYPE

Synthetic fibres such as nylon and polypropylene respond well to hot water extraction cleaning and are more resistant to alkaline chemicals and shrinkage than wool or wool-mix fibres. When cleaning wool or wool-mix fibres, always use approved cleaning solutions and avoid over-wetting.

TESTING FOR COLOUR FASTNESS

Locate an inconspicuous spot on the area to be cleaned. Test carpet for colour-fastness before proceeding. Apply S709 Multi Pro diluted at 1 part to 4 parts water and cover with a clean white towel or tissue and place a weighted object on top. Wait approximately 10 minutes then remove weight and examine towel or tissue. If there is no colour transfer the carpet should be safe to clean. If there is a colour change on the carpet or transfer of colour to the towel or tissue then carry out the same test with B109 Fibre & Fabric Rinse diluted at 1 part to 20 parts water. It may be possible to clean the carpet using B109 Fibre & Fabric Rinse. For further advice contact Prochem's technical department.

MOVING AND REPLACING FURNITURE

Remove the furniture from the area to be cleaned. Large pieces can be moved to the opposite end of the room from where you start cleaning and replaced when cleaning is completed. Plan your cleaning route. Start cleaning at the furthest point away from where you plugged in the machine and work back towards the outlet so that the power cable will not get in the way. After cleaning carpet, always place foil protector pads under furniture legs to prevent moisture from damaging the finish and dye and rust from transferring to the carpet.

DRY VACUUMING & PRE-TREATMENT

Vacuum clean the area using an upright vacuum. **DO NOT USE THIS MACHINE AS A DRY VACUUM!** Heavily soiled areas or areas of concentrated foot traffic should be pre-treated with recommended pre-spotting or pre-spray solutions.

CLEANING CARPET



FIG.1

PUTTING INTO SERVICE

Ensure the handle is in the upright and locked position suitable for the height and comfortable use of the operator.

Ensure all switches are in the off position.

Remove the bucket from the machine and fill to the max fill level indicator in the cleaning solution side of the bucket. Use only approved correctly diluted chemical (see chemical bottle label for correct dilution rates).

Add defoamer (as per label instructions) to the dirty side of the bucket which is a flexible bladder tank to reduce the build-up of foam.

Place the bucket back onto the machine ensuring that the dip tube travels to the bottom of the bucket and the filter on the end of the tube is free from debris.

Close the lid fully and lock using the bucket handle.

When moving the machine from place to place push down on the handle and wheel using the 2 rear wheels, only place the vacuum shoe onto the area to be cleaned when in use.

The machine must be used in an upright condition on a flat and level surface.

TO CLEAN

Turn switch to carpet position. If the machine is a Fivestar model, turn the solution control valve located on the side of machine to "carpet". Turn pump switch on. While pushing "activate" switch, pull machine while stepping backwards. Release "activate" switch, 6" before ending of cleaning stroke. Repeat cleaning stroke with 3" overlaps. Continue cleaning until cleaning solution is used. Empty bucket into waste sink or toilet then rinse dirty water section and repeat steps 1 and 2.

CHECK BUCKET LID

If excessive foam appears in lid, switch off, check dirty water side of bucket and add more Defoamer solution if required.

CLEAN UP

Clean lid filter screen and rinse out bucket. Wipe all surfaces including bottom of machine. Remove carpet lint and strings from brush and vacuum nozzle.

STORAGE AND TRANSPORTATION

The machine can be prepared for storage (indoors only), by ensuring the power cord is correctly wound around the cord wrap.

The bucket is empty and clean.

The lid is held open by the bucket handle.

The operators control handle is folded to the storage position.

Transporting the machine to another site in a vehicle can be carried out if the previous conditions are met but the lid must be locked down.

If the machine is to be lifted into a vehicle two lifting points are supplied one being the hinge point for the handle with the holding ridges the other a slot in the front of the machine as per fig 1.

Due to the weight of the machine it may require two people to lift it into any vehicle, or carry it upstairs.

Caution, under no circumstances should the machine be bumped up a flight of stairs using the handle, always empty the bucket before storage or transporting the machine.

USE OF PERSONAL PROTECTIVE EQUIPMENT (PPE)

Operation of this machine requires the use of protective latex gloves. Please be aware that the chemicals may require specific PPE to be worn. This can be found on the Material Safety Data Sheet (MSDS) for that particular product.

CLEANING UPHOLSTERY

CAUTION – WE STRONGLY RECOMMEND ATTENDING AN UPHOLSTERY CLEANING COURSE BEFORE ATTEMPTING TO CLEAN FABRIC UPHOLSTERY.

General instructions

Cleaning upholstery with success requires a good knowledge of the type of fabric to be worked on. Look for the cleaning instruction label sewn on the underside of the furniture for the recommended method of cleaning the fabric. If it calls for dry cleaning, do not attempt to clean with the wet extraction method. Otherwise, damage to the fabric could occur. Extraction works well on most wet-cleanable fabrics, including synthetic (acrylic) velvets. Before proceeding, test the fabric for colour-fastness. Apply a small amount of ready-to-use cleaning solution on the fabric in an inconspicuous area. Wait for 2 to 3 minutes and blot the area with a white terry cloth towel. If no colour comes off onto the towel, the fabric should be safe to clean. If a little colour comes off, there is some risk of colours running when you clean. It may be possible to stabilise colours by cleaning with B109 Fibre & Fabric Rinse. Refer to the "Testing For Colour-Fastness" under Cleaning Tips and Preparation. On heavily soiled areas like arm rests, pre-treat with a recommended pre-spray.

PREPARE THE MACHINE

Complete step 1 under Carpet Cleaning Instructions using approved upholstery cleaning solution. Disconnect vacuum hose with black hose cuff from lid and disconnect solution hose from back of machine. Replace them with the upholstery tool hoses.

TO CLEAN

Turn switch to upholstery position. If the machine is a Fivestar model, turn the solution control valve located on the side of the machine to "carpet". Turn pump switch on. Depress upholstery tool trigger while pulling tool across upholstery surface. Clean with the upholstery tool using as little solution as possible. Make overlapping passes to prevent streaking. Go over the area you just cleaned without depressing the solution trigger (vacuum only) and gauge the amount of moisture extracted for dryness. On heavily soiled areas like arm rests, pre-treat with a recommended pre-spray. Continue cleaning until cleaning solution is used. Empty bucket into waste sink or toilet then rinse dirty water section and repeat steps 1 and 2.

CHECK BUCKET LID

If excessive foam appears in lid, switch off, check dirty water side of bucket and add more Defoamer solution if required.

CLEAN UP

Clean lid filter screen and rinse out bucket.

CLEANING HARD FLOORS

(FIVESTAR MODEL ONLY)

If your machine has a "solution control valve" located on the side of the machine, you may clean hard floors using the following instruction.

Turn the solution control valve located on the side of the machine to "Floor".

WARNING: Use only approved floor cleaning solutions. To avoid possible scratching on soft floor surfaces such as vinyl and linoleum and stone floors such as marble and terrazzo, remove all abrasive materials from the surface to be cleaned using dust mopping and dry vacuuming. The Fivestar All-Floor is intended for use in general maintenance to wet clean hard floor surfaces. Do not use the machine to apply floor finish (emulsion polish), floor polish stripper or to vacuum up floor polish stripper.

PREPARE THE MACHINE

Make sure switch is in the "off" position and all hoses are connected. Using only approved floor cleaning solution, mix according to label instructions and add to "Cleaning Solution" side of machine bucket. Do not fill past "maximum fill level" indicated in bucket. To reduce foaming in dirty water section of bucket, add Defoamer solution according to label instructions. For excessive foam problems introduce Defoamer through the vacuum nozzle with vacuum switched on. Do not add Defoamer solution to cleaning solution side of machine bucket. Place bucket onto machine then close and secure lid using bucket handle.

TO CLEAN

Turn the solution control valve located on the side of machine to "Floor". Turn pump switch on. While pushing "activate" switch, pull machine while stepping backwards. Release "activate" switch, 6" before ending of cleaning stroke. Repeat cleaning stroke with 3" overlaps. Continue cleaning until cleaning solution is used. Empty bucket into waste sink or toilet then rinse dirty water section and repeat steps 3 and 4.

CHECK BUCKET LID

If excessive foam appears in lid, switch off, check dirty water side of bucket and add more Defoamer solution if required.

CLEAN UP

Clean lid filter screen and rinse out bucket. Wipe all surfaces including bottom of machine. Remove any accumulated dirt and debris from brush and vacuum nozzle.

ACCESSORIES & CHEMICALS

ACCESSORIES

HAND / UPHOLSTERY TOOL

Complete with 2.4 metre hose, this lightweight cleaning tool is designed for extraction cleaning stair carpeting, edges, small rugs and inaccessible areas. Also ideal for rinse extracting stains after treatment with an appropriate **Prochem** spotting agent. This tool can also be used for extraction cleaning of upholstery fabrics, subject to pre-testing of fabric and suitability of water-based cleaning.

VACUUM & SOLUTION EXTENSION HOSE

A 3 metre extension hose assembly for use with the upholstery tool when cleaning stairs and difficult to reach areas.

CHEMICALS

Prochem specialise in manufacturing chemical products for the soft furnishing cleaning industry, including carpets, floor coverings, upholstery fabrics and curtains. This section refers only to the basic **Prochem** chemicals for general on-site carpet cleaning using the hot water extraction method.

S775 EXTRACTION PLUS

A wide use carpet cleaning formula containing a high concentration of non-resoiling detergents, builders and brighteners for effective cleaning of synthetic and natural fibre carpets. S775 has an approximate pH of 8.5 and should be diluted with hot water at the rate of 10 ml. per litre (1 to 100).

S709 MULTI PRO

A concentrated pre-spotter and traffic lane cleaner for treating spots, stains and heavily soiled traffic areas prior to extraction cleaning. Dilute with warm water at 1 - 4 to 1 - 8 and apply by sprayer.

For best results, brush into pile using **Prochem** carpet pile brush before following up with extraction cleaning process. S709 has a diluted pH of 10.5, therefore always pre-test fibres for colour fastness before use.

B109 FIBRE & FABRIC RINSE

A mild acidic concentrate for use as a rinse to restore correct pH to the fibre. B109 will help to stabilise fugitive dyes and reduce the possibility of 'jute browning' caused by over-wetting or the use of alkaline cleaning solutions. B109 can be used in place of S775 in the extraction machine solution tank, or applied by sprayer after cleaning. Dilute 10 ml. per litre of warm water through your machine. B109 is normally only used when a dye test suggests the possibility of dye bleed or on light coloured carpets when JUTE is part of the construction and may cause BROWNING.

S760 LIQUID DEFOAMER

Always use S760 especially when foam problems from soapy residue left from previous shampoo cleaning are encountered. Mix 20 ml. of S760 with 500ml of cold water and add to vacuum hose and recovery tank. As you drain off to empty the recovered soiled solution, you simply add more S760 as necessary. Remember, it is only necessary to add S760 when extraction cleaning previously shampooed carpets, so always check the recovery tank for foam at the start of each job.

STAIN REMOVERS, SPOTTERS, PROTECTORS & DEODORISERS

Speciality products such as those listed above are available from the **Prochem** range. Refer to the chemical section of the Product Catalogue for more details. Individual Product Safety Data Sheets on all products are available direct from **Prochem** or Authorised **Prochem** Distributors.

GENERAL MAINTENANCE

The Prochem Fivestar machine is engineered and built to require a minimum of maintenance. But like any machine, it does require some care to keep it in optimum working condition. Careful attention to these maintenance instructions will give you maximum operating performance and will increase the life expectancy of the machine. To ensure a trouble-free machine, we strongly advise the following preventative maintenance.

DAILY MAINTENANCE

The following should be carried out at the end of each cleaning session.

POWER CABLE & PLUG

Check the condition of the power cable and plug. Make sure all wires are correctly located and tightly connected. If damaged, the power cable and plug assembly must be replaced.

DO NOT ATTEMPT REPAIR.

Instruction for replacement of power cable with combined plug (all machines)

!! CAUTION - ONLY QUALIFIED MAINTENANCE PERSONNEL SHOULD ATTEMPT THE FOLLOWING REPAIR

Should the power cable require replacement, please follow the instructions below.

1. The replacement cable and plug shall be of the same specification as the original Prochem part number BE4901 (3 core 1.5mm with 13Amp sealed plug unit)
2. Ensure that machine is disconnected from electrical supply and open electrical housing by means of tool required.
3. Disconnect the live (brown), neutral (blue) and earth (green/yellow) wires from the cable terminal block by means of unscrewing the terminal block wire clamp screws.
4. Release the outer cable clamp next to the terminal block by unscrewing the two securing screws, then unscrew the outer cable gland to release the cable which can then be pulled out of the cable gland assembly.
5. Insert the new cable through the gland, then secure and clamp the outer cable by means of tightening the outer cable gland and the two securing screws next to the terminal block.
6. Connect the live (brown), neutral (blue) and earth (green/yellow) wires to the cable entry gland terminal block by means of inserting the wire conductors into the terminal block as follows :-

The conductor of the wire coloured brown shall be connected to the terminal marked (L), the conductor of the wire coloured blue shall be connected to the terminal marked (N) and the conductor of the wire coloured green and yellow shall be connected to the terminal marked with the Earth symbol thus - 

7. Ensure that all connections are secure and close machine electrical housing and secure with tool required.

SOLUTION BUCKET

Rinse the solution tank and pump through with a solution of B109 Fibre & Fabric Rinse and warm water. Check the solution tank filter and clean if necessary. If damaged or compressed, unscrew the filter and re-shape or replace as necessary. **DO NOT** store hand tools, cables or hoses in the solution tank as this may damage the filter.

RECOVERY BUCKET (FLEXIBLE BLADDER)

Rinse with clean water and broad spectrum disinfectant solution. Clean the vacuum filter attached to the lid. Remove soil and lint build-up on the outside and inside of the filter screen attached to the lid. Lint should be cleaned off so that airflow is not impeded. Check the lid seal (dome gasket) and repair or replace to ensure a good seal on the top of the bucket.

CLEANING HEAD, HAND TOOLS AND HOSES

Inspect the wand shoe, rotating brush, bottom cover and hand tool for sharp edges or damage (if accidentally dropped).

Check the **spray jet** for debris, correct alignment and spray pattern. Clean if necessary using **only** a soft bristle brush - **DO NOT use metal or wire**. Rinse the upholstery tool vacuum hose with hot water to prevent soil build-up.

Check all nuts and bolts and tighten if necessary.

Pay particular attention to the base cover and vacuum shoe securing screws.

Always keep the machine clean inside and out.

WARNING! FREEZING PROTECTION

If your Fivestar machine is exposed to freezing weather with solution in the components, the solution will **FREEZE** and in most cases **SERIOUSLY DAMAGE** the machine. To avoid damage, consider the following in the winter season. When the machine is not in use, store it in a **heated building** and pump out all the cleaning solution from the machine and hand tool.

WEEKLY MAINTENANCE

At least once a week, inspect the internal components, solution fittings and electrical connections. Check for signs of **fluid leakage** and tighten or replace fittings as necessary. Make sure all **electrical connections** and **cables** are in place.

Solution Lines and Fittings

Flush the machine with a solution of 1 part water with 20 parts B109 Fibre & Fabric Rinse in order to neutralise the alkaline residue left by the cleaning solution.

Quick connect couplers (Hand Tool connection)

Spray with WD-40 or equivalent lubricant to prevent coupler from sticking.

SOLUTION PUMP

!! CAUTION - ONLY QUALIFIED MAINTENANCE PERSONNEL SHOULD ATTEMPT THE FOLLOWING REPAIRS

A diaphragm type pump is fitted to the Fivestar machine and requires little maintenance other than occasional inspection of the pump head to check for any fluid leakage. The following components should be inspected and cleaned, or replaced as necessary. See parts illustration in this manual for further reference.

- **CHECK VALVE ASSEMBLY**
- **DIAPHRAGM**
- **CAM DRIVE BEARING**
- **MOTOR**

In the event of a reduction in operating pressure, leakage or pump failure, refer to the '**Fault Finding Guide**' and contact your **Prochem** Distributor.

VACUUM MOTOR

!! CAUTION - ONLY QUALIFIED MAINTENANCE PERSONNEL SHOULD ATTEMPT THE FOLLOWING REPAIRS

The vacuum motor is lubricated for life - no additional lubrication is required. The only other maintenance that may be required is changing the motor brushes. **This should only be carried out by an individual with THOROUGH knowledge of electric motors.**

The brushes should be changed before the brush wears to within 3/8" of the brass holder.

With heavy usage we recommend that the brushes be checked every 3 months. The recommended inspection period for normal usage is at least every 6 months. The estimated brush life is approximately 400 to 450 hours, but inspection and replacement should take place at least every 350 hours to prevent the possibility that brush wear may cause damage to the vacuum motor.

On re-assembly, the lead wires must be kept away from the rotating parts and the motor frame. Always ensure that the green earth wire is re-connected to the vacuum motor body to ensure safe operation. To achieve maximum life, the brushes should be seated on the commutator before full voltage is applied. Do this by applying 50% of the rated voltage for thirty minutes. In the event of electrical or mechanical failure, refer to the General Fault Finding Guide page in this manual and contact your Prochem Distributor. Although some service parts are available, we recommend that defective vacuums be replaced.

GENERAL FAULT FINDING GUIDE

CAUTION - Repairs should only be carried out by a QUALIFIED AND FULLY TRAINED PERSON !

PROBLEM	POSSIBLE CAUSE
<i>ELECTRICAL SYSTEM</i>	
No electrical power	<ol style="list-style-type: none"> 1. Defective power cable 2. House or building circuit breaker tripped
Switch is turned on but power is intermittent to all motor(s).	<ol style="list-style-type: none"> 1. Faulty electrical cable 2. Defective switches 3. Loose terminal or terminal connections
<i>VACUUM SYSTEM</i>	
No vacuum	<ol style="list-style-type: none"> 1. Vacuum lid is not sealed against tank 2. Loose vacuum hose or vacuum connection
Low vacuum	<ol style="list-style-type: none"> 1. Accumulated dirt on lid screen 2. Worn out vacuum lid gasket 3. Lint & dirt build-up on vacuum nozzle 4. Defective vacuum hose 5. Loose connection in the vacuum motor
<i>SOLUTION SYSTEM</i>	
Pump motor is on but there is no spray	<ol style="list-style-type: none"> 1. Solution side of bucket is empty 2. Clogged spray tip 3. Clogged solution tank filter 4. Blocked female quick connector 5. Damaged pump diaphragm 6. Damaged or clogged pump check valve 7. Leak from pump head
Uneven or weak spray	<ol style="list-style-type: none"> 1. Partially clogged spray tip 2. Partially clogged solution tank filter 3. Partially clogged pump head or check valve 4. Worn pump bearing (excessive noise) 5. Damaged pump diaphragm 6. Defective motor or rectifier 7. Worn or damaged spray tip
<i>BRUSH SYSTEM</i>	
Motor runs but brush does not turn	<ol style="list-style-type: none"> 1. Broken drive belt 2. Brush jammed
Brush motor fails to turn on after circuit breaker has been reset	<ol style="list-style-type: none"> 1. Brush jammed 2. Blown breaker 3. Defective motor 4. Defective switch 5. Loose wiring connection

MACHINE PARTS LIST

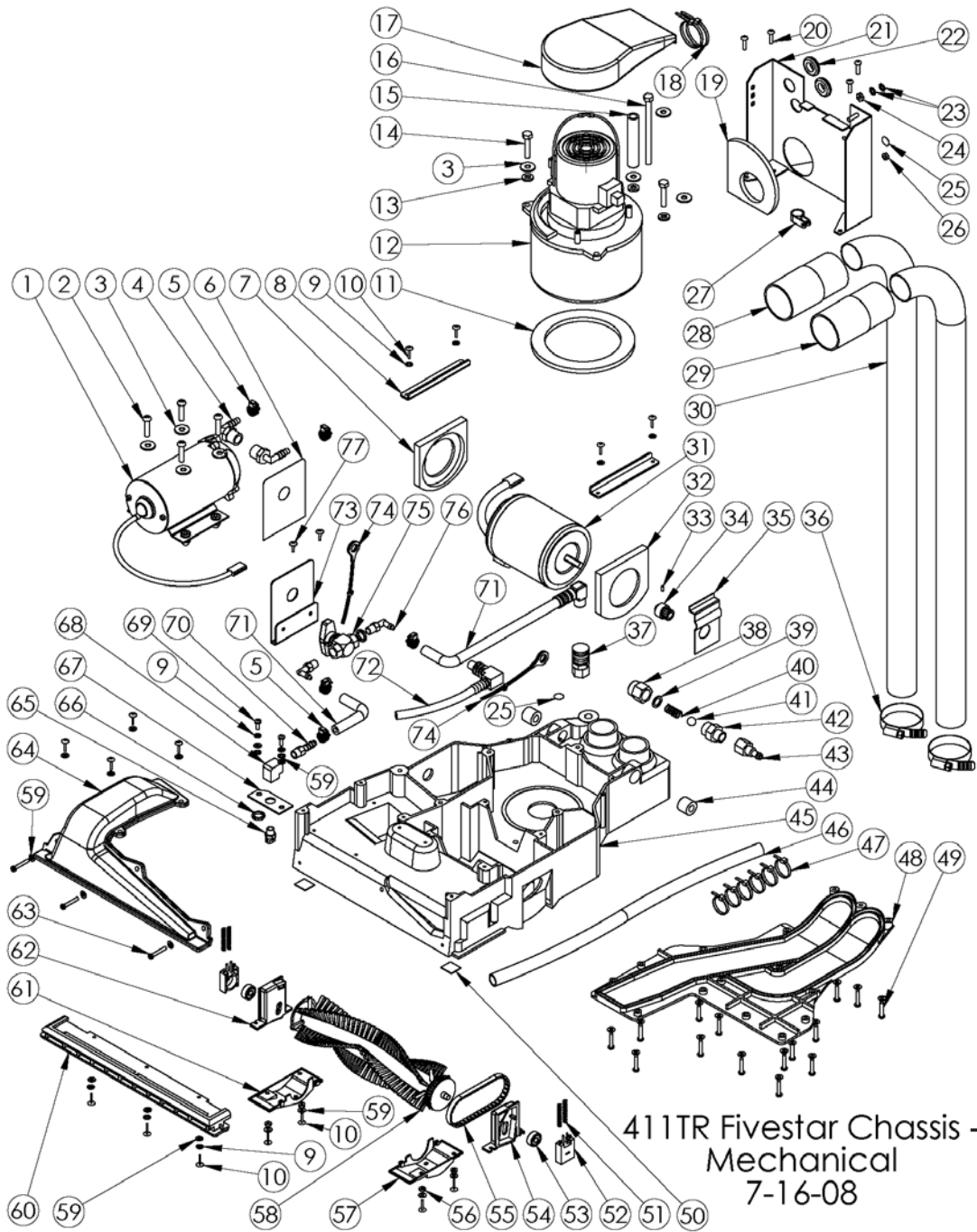

REF.	STOCK CODE	PART NO.	DESCRIPTION	QTY
1	E10763-1	G10763-1	PUMP 85PSI 220-240V CE	1
2		C02308	0.25 -20 X 1 ROUND HEAD SCREW	4
3	JE00233	C00233	WASHER, FLAT 0.25	8
4	FJ00055	PN16-6-38	PLASTIC ELBOW 1/4H X 3/8 NPT	2
5	TT00640 RS5216	J00640 525-177	SCREW CLAMP SS 20MM 3/8 HOSE HOSE CLIP 9.5 - 12MM (ALTERNATE)	5
6		H10778	LABEL SOLUTION CONTROL	1
7		E10446	MOTOR MOUNT REAR FLOJET	1
8		D10447	CLAMP, BRUSH MOTOR	2
9	E02248	C02248	LOCK WASHER #8 INT STAR	9
10	E10737	C10737	SCREW 8 - 32 X 0.625" SS TRUSS	15

11	E02435-A	E10521	GASKET VAC MOTOR 20LB PORON	1
12	LA4503P E90007-1	117148-13 G90007-1	VAC MOTOR 2-STAGE REVERSE FAN 220-240V CE FIVESTAR VAC MOTOR 2-STAGE REVERSE FAN 220-240V CE COMET	1 1
13	E10674	C10674	WASHER CUSHIONING	3
14	E02310	C02310	HEX BOLT ¼ - 20 X 1.25"	2
15	E10691	K10691	PVC PIPE ¼ SCH 80	1
16	E02306	C02306	HEX BOLT ¼ - 20 X 4"	1
17	E10542	F10542	INTERCOOLER BLACK	1
18	RS4907	B00191	NYLON TIE 11" BLACK	2
19		E10650	GASKET BACKPLATE (S3) 5S	1
20		C02288	SCREW #8 X 0.63 PLASTITE PH	4
21		D10475	BACKPLATE BLACK	1
22		E10520	GROMMET NEOPRENE 1" OD	2
23		C00256	LOCKWASHER #10 EX STAR	2
24		C00264	HEX NUT 10 – 32 SS	1
25		H10911	LABEL GROUNDING MARK	2
26		C00280	HEX NUT 8 – 32 BLACK ZINC	1
27		B03176	CABLE CLAMP NYLON 0.5"	1
28	PF4011	J10744-1	CUFF BLACK 1.75" SLIP-ON	1
29	PF4011	J10744	CUFF GREY 1.75" SLIP-ON	1
30	E00618-1	J00618-1	HOSE 1.5" WIRE SUPPORTED GREY 34"	2
31	FJ4402	S2039-001A	BRUSH MOTOR 220-240V CE	1
32	E10445	E10445	MOTOR MOUNT, FRONT	1
33	E02260	C02260	SET SCREW 8 – 32 X 0.25"	1
34	E10437	D10437	PULLEY 16 TOOTH DIECAST ZAMAC 3	1
35	E10665	D10665	BRACKET BELT LIMIT 5S	1
36		J00650	SCREW CLAMP #24 1.25"	2
37	E00109	A00109	QUICK DISCONNECT 1/8F X 1/8FP	1
38	E00097-A	A00097A	CAP, IN-LINE FILTER (LATER VERSION)	1
39	E13046	C13046	FLAT WASHER 0.375" BRASS (LATER VERSION)	1
40	E12094	D12094	SPRING 0.75 X 0.325 (LATER VERSION)	1
41	E12093	D12093	BALL 0.437" 302SS (LATER VERSION)	1
42	DE4906	A00094C	CHECK VALVE BODY (LATER VERSION)	1
43	GU4014 GU4013	A12091	QUICK DISCONNECT PLUG 1/4MP BRASS (LATER VERSION) MALE PLUG ¼ (EARLIER VERSION)	1 1
44	E10470	E10470	TUBE LATEX, AXLE	2
45	E10427	F10427-2	CHASSIS (INCLUDES ITEMS 48, 49, 56, 57 61)	1
46		F00463	CORRUGATED LOOM 0.15"	1
47	RS00190	B00190	NYLON TIE 4"	6
48	E10430	10430A	BOTTOM COVER INJECTION MOULDED	1
49		C11020	SCREW PLASTITE 8-16 X 0.875"	15
50		E10651	PAD TEFLON, BRUSH ASSEMBLY 5S	2
51	E10426	D10426	SPRING, BRUSH	4
52	E10410	F10410-1	SLIDE BLOCK, BRUSH BEARING	2
53	E10425	10425	BEARING, BRUSH	2
54	E10413	F10413	BRUSH RETAINER, RIGHT	1
55	E10448	L10448	DRIVE BELT, 7MM X 300MM	1
56	E10736	C10736	WASHER, CUSHIONING #8	4
57	E10423	F10416-1	BRUSH RETAINER COVER (PULLEY END)	1
58	E10420A E10409A	10420-3A 10409A	BRUSH, SLOPED 4-ROW FIVESTAR BRUSH ASSY 3-ROW COMET	1 1
59	E02231	C02231	WASHER #8 SAE SS	33
60	E10474	10474A	VACUUM SHOE	1
61	E10416	F10423	BRUSH RETAINER COVER (NON-PULLEY)	1
62	E10422	F10422	BRUSH RETAINER, LEFT	1
63	E10785	C10785	SCREW 8-32 x 1" TRUSS PHILLIPS	3
64	E10429	10429A	COVER, SUCTION	1
65	E00089-6	A00089-5	SPRAY TIP 9504 X 0.125" MP	1
66	E02298	C02298	WASHER, NYLON	2
67		D10506	BRACKET, SPRAY NOZZLE	1
68	E00073	A00073	90 ELBOW 0.125"FP X 0.125"PF BRASS	1
69		C00310-12	SCREW 8-32 X 0.5" PHILLIPS	2
70	WL4001	A00136	¼ BARB X 1/8MP BRASS	1
71	WP4001	12132A	HOSE 24" x 1/4" BLACK HOSE	2
72		10990A	HOSE	1
73		D10787	BRACKET, FLOOR VALVE (FIVESTAR)	1
74		B10528	GROUND WIRE QD 21" 5S	2
75	E10758	G10758	BALL VALVE (FIVESTAR)	1
76	E00130	A00130	90 ELBOW 0.125MP X 0.25" BARB NYLON (FIVESTAR)	2
77		C02296	#10 X 0.5" SHEET METAL SCREW	2

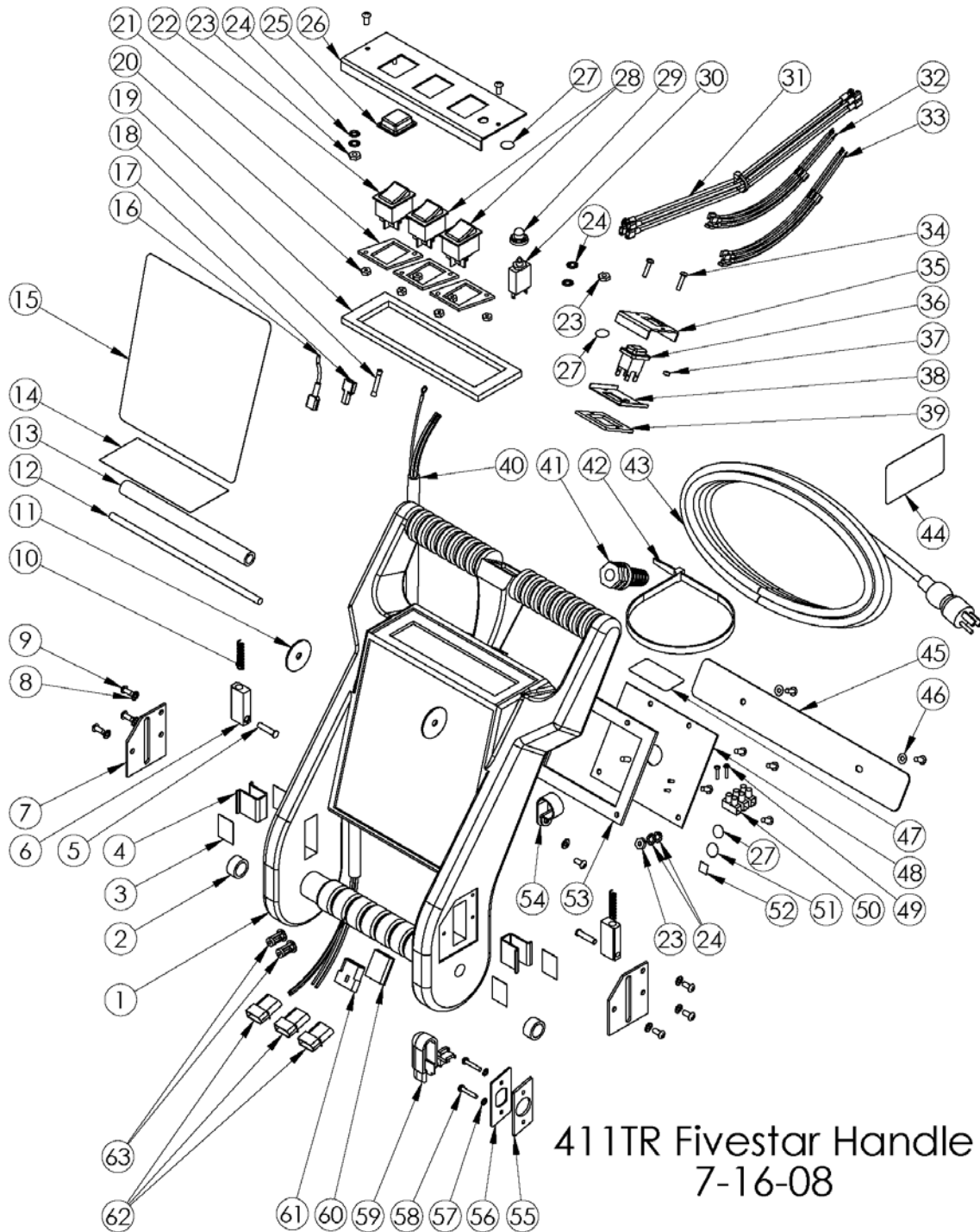

411TR Fivestar Handle
7-16-08

REF.	STOCK CODE	PART NO.	DESCRIPTION	QTY
1	E10482	F10482	HANDLE	1
2		A10600	BUSHING PVC 0.75 X 0.375	2
3		E10805	SHIM, TEFLON, HANDLE LOCK	4
4	E10690	D10690	BRACKET, GUIDE LOCK	2
5	E10692	C10692	DOWEL, SLIDE LOCK, STEEL	2
6	E10689	F10689	SLIDE LOCK, NYLON	2
7	E10487	D10487	PLATE, COVER, LOCKING	2
8	E02248	C02248	LOCKWASHER #8 EXT. STAR	6
9	E00311	C00311	SCREW 8-32 X 0.375 RH	15
10	E10494	D10494	SPRING, LOCK MECHANISM	2

11	E10730	C10730	WASHER, NYLON 1.25" OD	1
12	E10479	D10479	ROD, PULL LOCK	1
13	E10691-1	F10691	TUBE, PULL LOCK 0.025 X 6.75 PVC BLACK	1
14		H10777	LABEL, HANDLE ADJUST	1
15			LABEL, HANDLE. AVAILABLE FROM PROCHEM	1
16		B00177	SPADE CONNECTOR FEMALE	1
17		B00177-1	TERMINAL LUG, FEMALE QD 0.25 X 0.032	1
18		B00181	WIRE SPLICE BLUE, 1 WIRE	1
19		E10698	GASKET, SWITCHPLATE	1
20		C00277-1	HEX NUT 6-32 SS	6
21		D10954	PLATE, COMPRESSION	3
22	AP02211	B00188	SWITCH, ROCKER DPDT BLACK	1
23		C00264	HEX NUT 10-32 SS	3
24		C00256	LOCKWASHER #10 EXT. STAR	6
25	E00214-2	B00214-2	COVER, SWITCH ROCKER	1
26		D10713	PLATE SWITCH, 3 SWITCH 5S	1
27		H10911	LABEL GROUNDING MARK	3
28	E02211-1	B02211-1	SWITCH ROCKER, GREEN LIGHT	2
29	E02193	B02193	SEAL, CIRCUIT BREAKER	1
30	E02191	B02191	CIRCUIT BREAKER 1A RE-SET BUTTON (BRUSH)	1
31		B10570	HARNESS, MOMENTARY SWITCH	1
32		B10747	HARNESS, JUMPER, SWITCHES	1
33		B10866	WIRE HARNESS 3-SWITCH 5S	1
34		C10739	SCREW 6-32 X 0.625 PAN HEAD PHILLIPS SS	2
35		D10481	PLATE, MOUNTING, MOMENTARY	1
36	E10513	B10513	SWITCH, PUSH BUTTON 250V	1
37		K00685	SPACER, CORD WRAP 1204AC	1
38		D10590	PLATE, MOMETARY SWITCH	1
39		E10705	GASKET, MOMENTARY SWITCH	1
40		B10553	MAIN HARNESS 5S	1
41	E11199	B11199	STRAIN RELIEF PIGTAIL	1
42	RS4907	B03229	TIE FOR UPHOLSTERY TOOL	1
43	BE4901A	B10719	POWER CABLE & PLUG UK 220-240V CE 25FT	1
44		H02548-2	LABEL, IMPORTANT, CORD	1
45		D10501	PLATE, CORD WRAP	1
46		C02231	WASHER #8 SAE SS	3
47		H10976	LABEL UL STD 561-507	1
48		D10496	COVER PLATE, BLACK, POWER	1
49		C90008	4-40 X 0.5" PHILLIPS	2
50	E02190	B02190	TERMINAL BLOCK 3 POLE	1
51		H10914	LABEL, NEUTRAL	1
52		H11913	LABEL, LIVE	1
53		E10717	GASKET, POWER CORD 5S	1
54		B00183	CABLE CLAMP, NYLON 0.75	1
55		E10723	GASKET, STRAIN RELIEF 5S	1
56		D10618	PLATE, STRAIN RELIEF BLACK	1
57		C00258-2	LOCKWASHER #6 EXT. STAR	2
58		C90006	SCREW 6-32 X 0.75" PHILLIPS	2
59		B10734	STRAIN RELIEF, HANDLE	1
60		B11729	MOLEX, MALE	1
61		B11730	MOLEX, FEMALE	1
62		B02176	3-C MOLEX FEMALE	3
63		C10725	JACKNUT 6-32 ALUMINUM	2
	E90001A	B90001	FILTER EMC RFI 250V	1

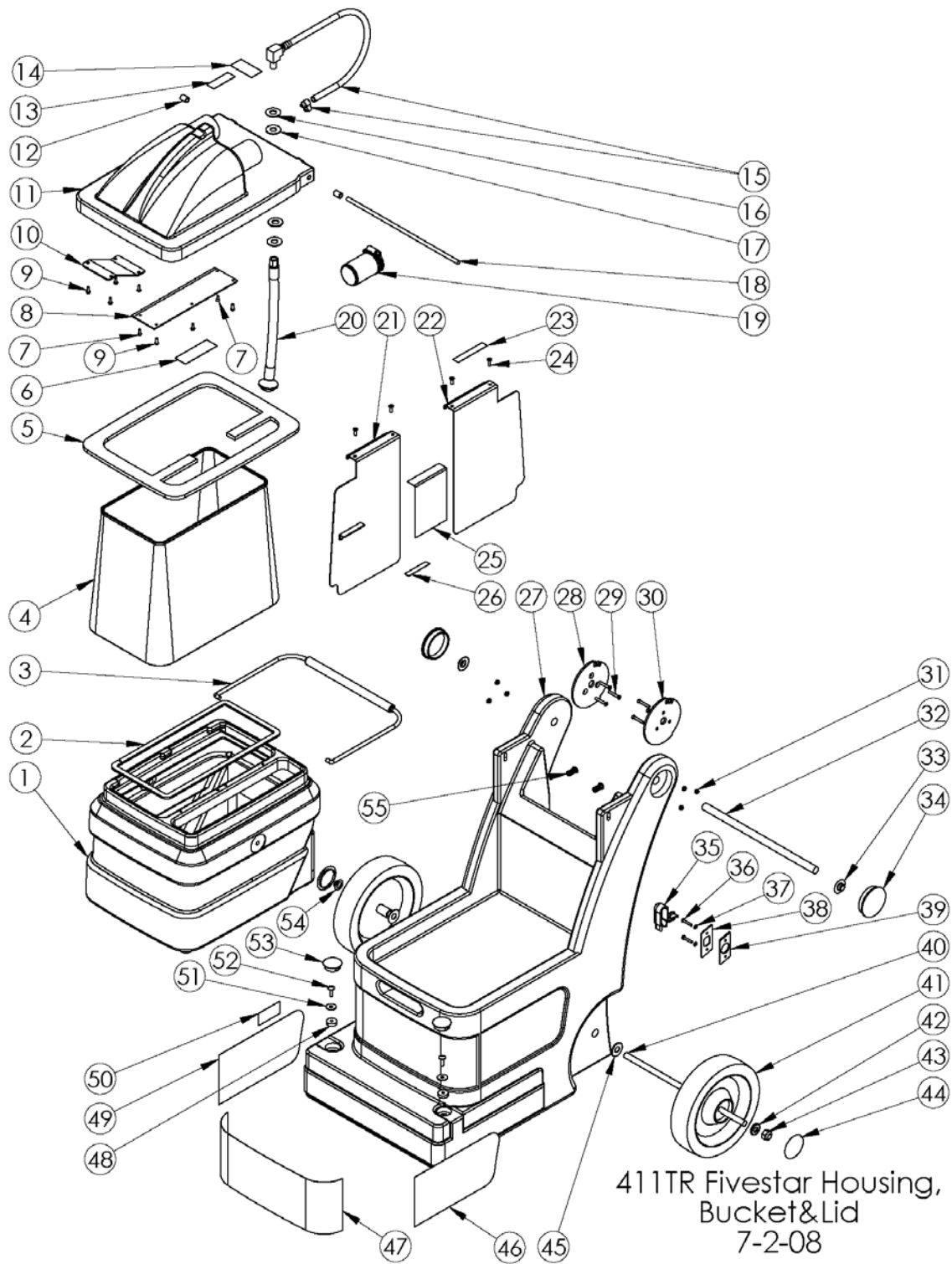

REF.	STOCK CODE	PART NO.	DESCRIPTION	QTY
1	E10484A E10539	10484A 10538-1A	BUCKET ASSY GRANITE FINISH BUCKET ASSY PLAIN GREY	1
2	E10771	E10771	GASKET, BUCKET, .375 X 33	1
3	E10452	D10452	ASSY BAIL HANDLE	1
4	E10490A	10490A	ASSY BLADER	1
5	E10533	E10533	GASKET DOME (S3) 5S	1
6		H10565	LABEL, FILTER SCREEN	1
7	E02238-38	C02238-38	SCREW 6-32 X 0.375 SS	2
8	E10761	D10761	PLATE LID GASKET, BLACK	1

9	E00324-38	C00324-38	SCREW 6-32 X 0.375 RH SS	7
10	E10768	D10768	DEFLECTOR PLATE BLACK	1
11	E10454	10454A	DOME	1
12	E10732	E10732	TUBE LATEX 0.25" ID	2
13		H10574	LABEL PATENTS	1
14		H10483	LABEL WARNING KEEP INSIDE	1
15		10780A	ASSEMBLY, HOSE PUMP TO DOME	1
16		C10503	WASHER DELRIN 0.375 ID	2
17	E10504	E10504	GASKET, WASHER, DOME HOSE	2
18	E10524	D10524	SHAFT DOME HINGE	1
19	E10767	D10767	FILTER AIRFLOW 1.5"	1
19A	E13314		FILTER AIRFLOW 1.5" NEW STYLE	
20	E10543-1A	10543-1A	ASSY. HOSE WITH FILTER	1
	E10543A	10543A	ASSY. HOSE W/FILTER & CHECK VALVE E10731 (EARLIER VRS)	1
	E10478	D10478	SOLUTION FILTER 50 MESH	1
21		D10760	PLATE DIVIDER BUCKET FRONT EPOXY GREY	1
22		D10762	PLATE DIVIDER BUCKET REAR EPOXY GREY	1
23		H10572	LABEL ANTI-FOAM	1
24		C00307-12	SCREW 8-32 X 0.5 FLATHEAD	4
25		H10740	LABEL CLEANING SOLUTION	1
26		H10571	LABEL FILL LEVEL TANK	1
27		F10483	MOTOR HOUSING	1
28	E10486-1	D10486-1	DISC HANDLE LOCKING LEFT	1
29	E90010	C90010	SCREW 8-32 X 1" FH	6
30	E10485-1	D10485-1	DISC HANDLE LOCKING RIGHT	1
31	E02320	C02320	LOCK NUT 8-32 NYLON SS	6
32		D10508	TUBE HANDLE	1
33	E02305	C02305	CAP NUT 0.5" PUSH ON	2
34	E010142	K010142	PLUG 2" BLACK	2
35		B10734	STRAIN RELIEF, HANDLE	1
36		C90006	SCREW 6-32 X 0.75" PHILLIPS	2
37		C00258-2	LOCKWASHER #6 EXT. STAR	2
38		D10618	PLATE, STRAIN RELIEF, BLACK	1
39		E10723	GASKET, STRAIN RELIEF 5S	1
40		D10523-3	AXLE, WHEEL	1
41	E10458	G10458	WHEEL 7" X 0.375" BORE GREY	2
42		C00252	WASHER 0.375" FLAT	1
43		C11558	LOCKNUT 0.375 - 16 NYLON	1
44	E10458-2	G10458-2	HUB CAP WHEEL BLACK.	2
45		C10546	FLAT WASHER 1" x 0.48"	2
46		H10729	LABEL, MOTOR HOUSING, RIGHT	1
47		H10727	LABEL, MOTOR HOUSING, FRONT	1
48	E10757	C10757	WASHER, CUSHIONING, 80 SHORE	2
49		H10728-SP	LABEL, MOTOR HOUSING, LEFT	1
50		H10577	LABEL, CAUTION	1
51	E90009	C90009	WASHER FLAT SS 0.678"	2
52	E90007-A	C90007	SCREW 10-32 X 0.625" PHILLIPS	2
53	E10510	K10510	PLUG, 1" ROUND SNAP-IN	2
54	E02305-1	C02305-1	CAP NUT 0.375" PUSH ON	1
55		C10725	JACKNUT 6-32 ALUMINUM	2
	AC322		HOSE & HAND TOOL ASSEMBLY	
	AC341		VAC & SOL HOSE ASSY 3M FOR USE WITH CARPET WANDS (AC330 / AC1030)	
	GU4013 (X1) + WP4001 (X3)		PRIME HOSE ASSEMBLY ITEMS	

PUMP PARTS LIST

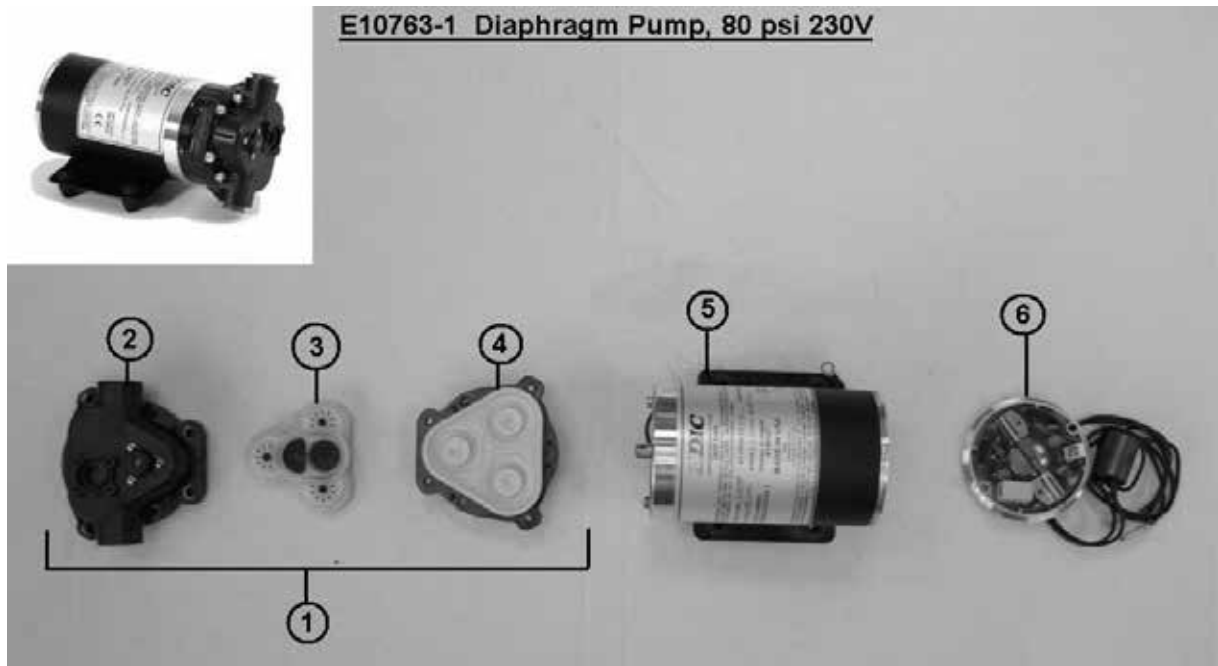

REF	STOCK CODE	PART NO	DESCRIPTION	QTY
1	E11162	G11162	150PSI PUMP HEAD (PLEASE REQUEST WHEN PURCHASING THAT BYPASS BE SET TO 85PSI)	1
2	E11764UHA	G11764-1-UHA	UPPER HOUSING(FOR E11162)	1
3	E11764VHA	G11764-1-VHA	VALVE REPAIR KIT	1
4	E11764LHA	G11764-1-LHA	DIAPHRAGM AND DRIVE BEARING ASSY	1
5			MOTOR 230V AC	1
6	E11764EBK	G11764-1-EBK	CARBON BRUSH KIT	1

FIVESTAR & COMET HAND TOOL PARTS LIST

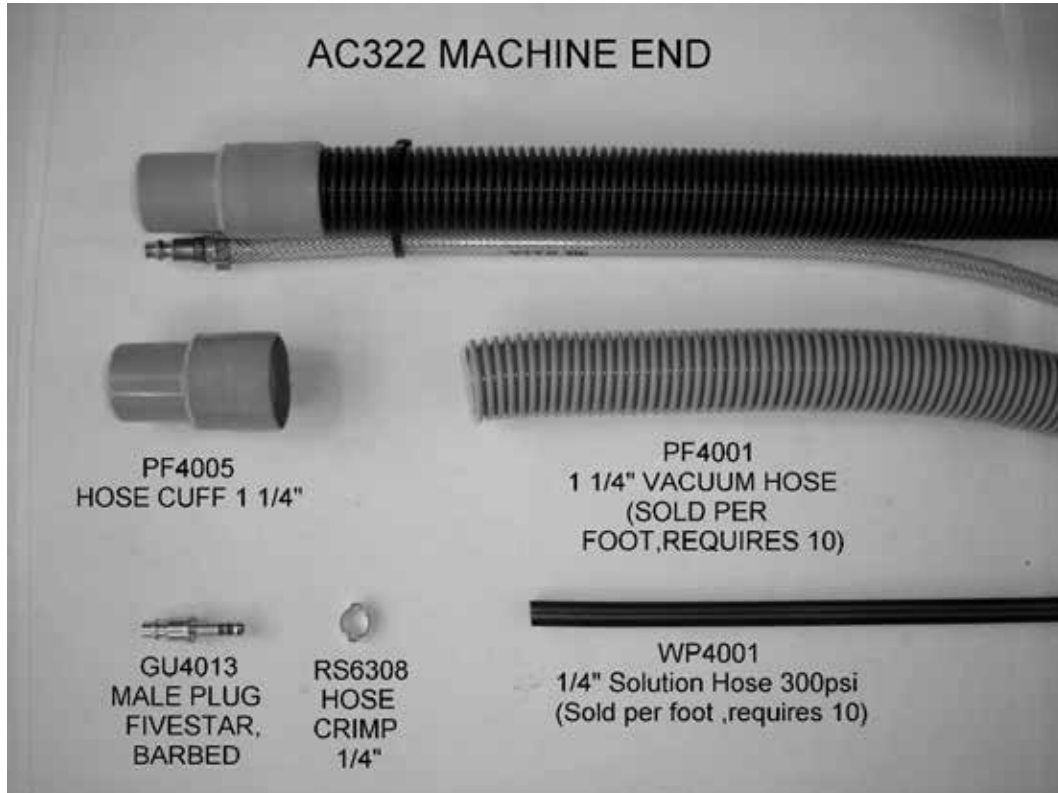

WIRING DIAGRAM

MODELS TR300 TR419
220 – 240V 50HZ, CE

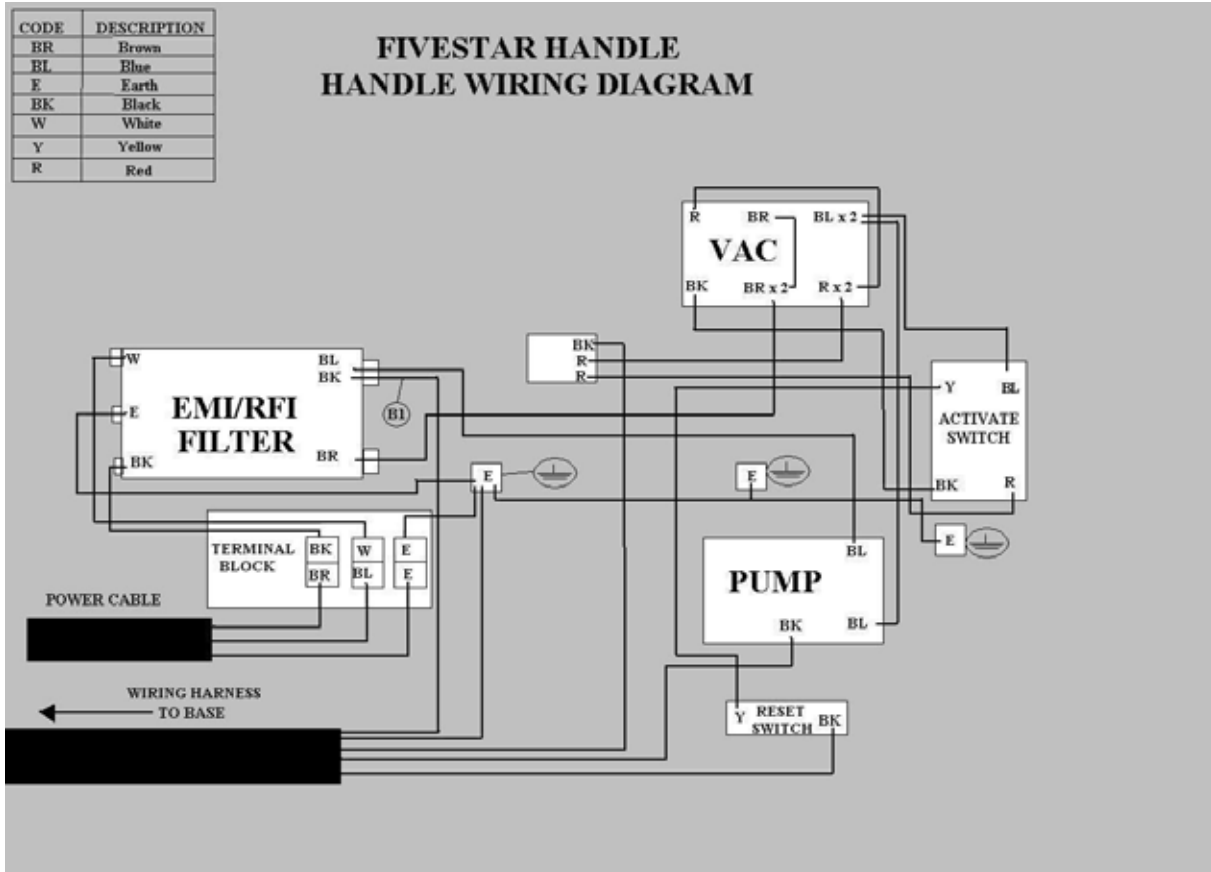

CODE	DESCRIPTION
BR	Brown
BL	Blue
E	Earth
BK	Black
W	White

FIVESTAR BASE WIRING DIAGRAM

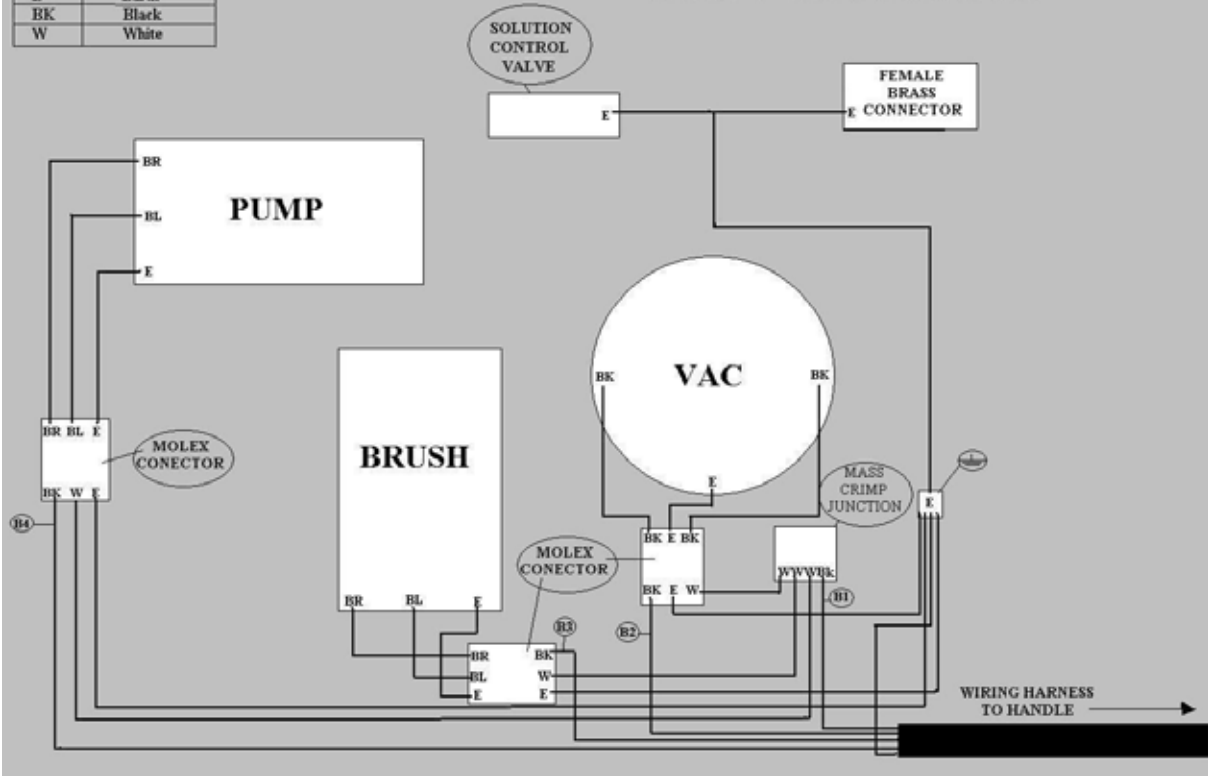

DECLARATION OF CONFORMITY

We:

Prochem Europe Ltd.,
Oakcroft Road,
Chessington,
Surrey, KT9 1RH
UK
(Importer / EC Responsible Person)

E.D.I.C
1753, Blake Avenue,
Los Angeles,
California, 90031-1006
USA
(Manufacturer)

Declare that the product(s):

Type(s): **FIVESTAR, COMET**
Model(s): **TR300 / 428TR-P, TR419 / 419TR-P**
Description: **CARPET CLEANING MACHINES 220 - 240V 50Hz**

Have been manufactured in conformity with the following standards and specifications:

EN 60335-1
EN 60335-2-68
EN 50081-1
EN55014-1
EN55022
EN61000-3-2
EN61000-3-3

And comply with the requirements of (as amended):

2014/35/EC **Low Voltage (LVD) Directive**
2004/108/EC **Electromagnetic Compatibility (EMC) Directive**
2015/863/EU **RoHS Directive**

A Technical file is held by Prochem Europe Ltd.

Certificate of compliance and test reports have been issued by:

Intertek Testing Services
ETL Testing Laboratories
27661 La Paz Road
Laguna Niguel, CA 92677 USA
Ref: 9831021/01-04

SGS United Kingdom Ltd.
Unit 10, Bowburn South Industrial Estate
Bowburn, Durham DH6 5AD
Ref: DUR 40571/2/R/SW/03
DUR 40571/1/EMC/CL/03

Signed
(For and on behalf of the Importer / EC Responsible Person)



Name: J Hattersley
Position: Equipment Product Manager
Place of Issue: Chessington UK
Date of Issue: 25/3/2021