

PROCHEM®

PEAK 500

Operation and Service Manual

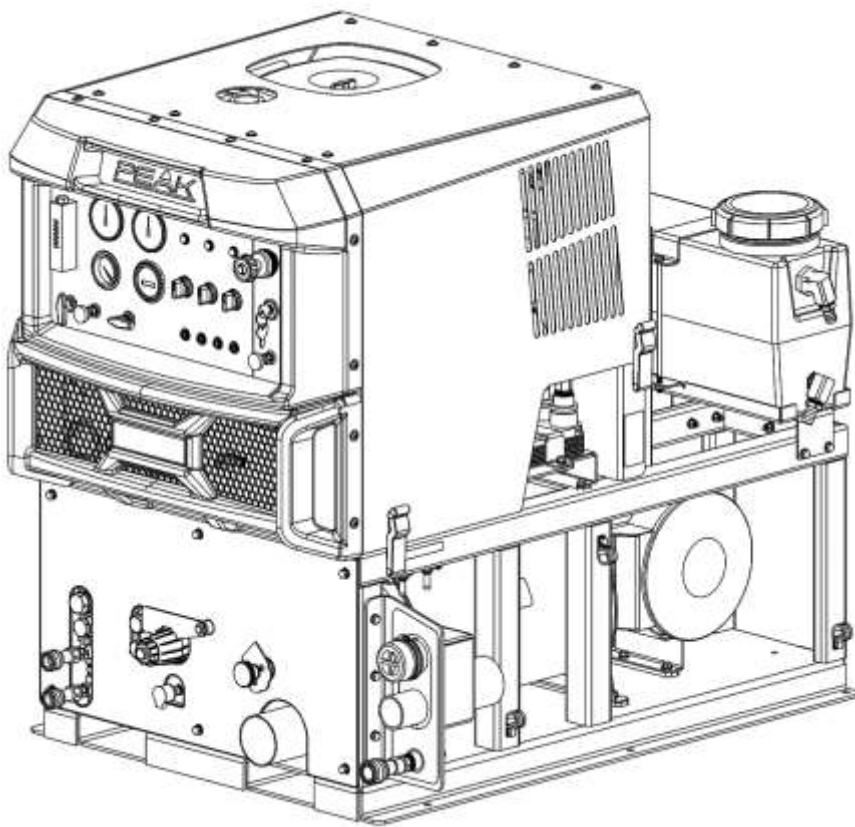

Manual P/N 49-169
Revision A, June 2018

UNIT DATA LABEL

Model: _____

Date of Purchase: _____

Serial Number: _____

Dealer: _____

Address: _____

Phone Number: _____

Sales Representative: _____

Congratulations on the purchase of your Mobile Cleaning Unit. This instruction manual is a guide for operating and servicing your equipment. **Read this manual completely before installing or operating this unit.**

Proper operation and service are necessary to ensure the outstanding performance of this unit. When properly maintained, your truck-mount will have a long and trouble-free life.

The service methods outlined in this manual are detailed in a manner that operation and servicing may be performed properly and safely. Because service levels vary due to the skill of the mechanic, tools and parts availability, ensure that prior to attempting any maintenance or repair, you are familiar with the equipment and have all the proper tools to complete the task. Please call a **Legend Brands** service or customer care representative at 866-445-3030 for help with maintenance, repair, warranty and parts related questions.

THIS UNIT MUST BE INSTALLED BY THE DEALER THAT YOU PURCHASED IT FROM IN ACCORDANCE WITH THE PRESCRIBED INSTALLATION PROCEDURES.

Information in this document is subject to change without notice and does not represent a commitment on the part of Legend Brands.

WARRANTY REGISTRATION

Thank you for purchasing a Legend Brands product. Warranty registration is quick and easy. Your registration will allow us to serve you better over the lifetime of the product.

To register your product go to:

<https://www.legendbrandscleaning.com/Warranty>

For customer assistance:

866-445-3030

LEGEND BRANDS LIMITED WARRANTY

Legend Brands Model Peak 500

What Does This Warranty Cover?

This warranty covers the Legend Brands Model Peak 500 and is provided to the original purchaser only.

How Long Does This Warranty Last?

This warranty runs for:

Two (2) years from the date of installation on parts and labor (Excluding normal maintenance items.) Factory installed original belts are covered for 500 hours. Water box, recovery tank and frame are covered for five years. All other components including seals, o-rings and electrical components are covered for the entire two year warranty period.

What Legend Brands Will Do:

If a defect in materials or workmanship occurs within the warranty period, Legend Brands at its election will repair or replace the defective part at no charge.

What This Warranty Does Not Cover:

This warranty does not cover or apply to defects due directly or indirectly to misuse, abuse, disassembly, alteration, corrosive chemicals, improper voltage, improper fuel, fire, flood, negligence, accident, improperly or incorrectly performed maintenance or repair, or failure to perform necessary or recommended maintenance or repair (See your Owner's Manual) or if the use of this product is not in compliance with the instructions and specifications for its use. This warranty does not cover normal maintenance items such as air and oil filters, lubricants and tune up parts. Paint is not covered. Water box, recovery tank and frame are covered for five years. All other components including seals, o-rings and electrical components are covered for the entire two year warranty period. We limit all implied warranties to:

Two (2) years from the installation date on parts and labor. It is strongly recommended that this truck mount be used with, and only with, Legend Brands recommended chemicals and as directed by label instructions on chemical bottles.

OTHER THAN THE WARRANTIES PROVIDED HEREIN, LEGEND BRANDS MAKES NO EXPRESS OR IMPLIED, ORAL OR WRITTEN WARRANTIES WITH RESPECT TO THIS PRODUCT OR WORKMANSHIP AND ALL WARRANTIES IMPLIED BY LAW INCLUDING ANY WARRANTIES OF MERCHANTABILITY OR FITNESS FOR A PARTICULAR PURPOSE ARE LIMITED TO THE DURATION OF THIS WARRANTY.

Some states do not allow limitations on how long an implied warranty lasts, so the above limitations may not apply to you. WE SHALL IN NO EVENT BE LIABLE FOR DEATH, INJURIES TO PERSONS OR PROPERTY OR FOR INCIDENTAL, CONTINGENT, SPECIAL OR CONSEQUENTIAL DAMAGES ARISING FROM USE OF OUR PRODUCTS. Some states do not allow the exclusion or limitation of incidental or consequential damages, so the above limitation or exclusion may not apply to you.

How Do I Get Service?

In order to be eligible for service under this warranty you MUST do the following: (a) fill out the warranty registration card on-line within thirty (30) days of the installation of our product; (b) write or call a service representative at Legend Brands for a return material authorization (RMA); and (c) have the serial number available. Proof of proper maintenance may be required before warranty is granted.

Contact us at:

Legend Brands

2604 Liberator, Prescott, AZ 86301

Phone: 928-445-3030 / 866-445-3030

If Legend Brands uncovers a defect we will repair or replace the product, at our election. Ground shipping and transportation costs will be covered by the manufacturer. Returning defective parts to the manufacturer, if required, shall be the responsibility of the purchaser. Warranty may be denied if defective parts are not returned within 90 days. If it is determined that there is no defect in the product, or that the defect resulted from causes not within the scope of our warranty, then the product will be repaired or replaced only at your request and at your expense and you must bear all shipping costs.

How Does State Law Apply?

This warranty gives you specific legal rights, and you may also have other rights which vary from state to state.

TABLE OF CONTENTS

SECTION ONE: GENERAL INFORMATION	1
HOW TO USE THIS MANUAL	1
SAFETY	2
SPECIFICATIONS	6
LAYOUT WITH 90 GALLON WASTE TANK (IN INCHES)	7
LAYOUT WITH 120 GALLON WASTE TANK (IN INCHES)	8
INSTALLATION REQUIREMENTS	9
FUEL REQUIREMENTS	9
ENGINE REQUIREMENTS	10
CHEMICAL REQUIREMENTS	10
WATER REQUIREMENTS	10
RECEIVING YOUR TRUCK-MOUNT UNIT	11
SECTION TWO: INSTALLATION	13
INSTALLATION OF FUEL LINES	15
BATTERY CONNECTION	20
FIRE EXTINGUISHER	20
CONSOLE TO WASTE TANK CONNECTIONS	21
SECTION THREE: USING YOUR CLEANING SYSTEM	22
WATER HEATING SYSTEM	23
VACUUM SYSTEM	25
CHEMICAL PUMPING SYSTEM	26
PREPARATION AND OPERATION	27
FREEZE PROTECTION / DESCALING	37
SECTION FOUR: SERVICE AND MAINTENANCE	39
PEAK 500 MAINTENANCE CHART	39
PEAK 500 SERVICE INTERVAL CHART	40
MAINTENANCE AND SERVICE ADJUSTMENTS	41
TROUBLESHOOTING	54
SECTION FIVE: PARTS LISTING AND REFERENCE	60
PEAK 500 WIRING DIAGRAM	105
HOSE IDENTIFICATION AND ROUTING	107
FUEL HOOK-UP KITS	108

SECTION ONE: GENERAL INFORMATION

HOW TO USE THIS MANUAL

This manual contains the following sections:

- How to Use This Manual
- Safety
- Installation
- Operation
- Maintenance & Service
- Parts Listing & Diagrams

The **HOW TO USE THIS MANUAL** section will tell you how to find important information for ordering correct repair parts.

Parts may be ordered from authorized dealers. When placing an order for parts, the machine model and machine serial number are important. Refer to the **MACHINE DATA** box which is filled out during the installation of your machine. The **MACHINE DATA** box is located on the inside of the front cover of this manual.

Model: _____
Date of Purchase: _____
Serial Number: _____
Dealer: _____
Address: _____
Phone Number: _____
Sales Representative: _____

The model and serial number of your unit is located on the front left side of the frame as shown here:

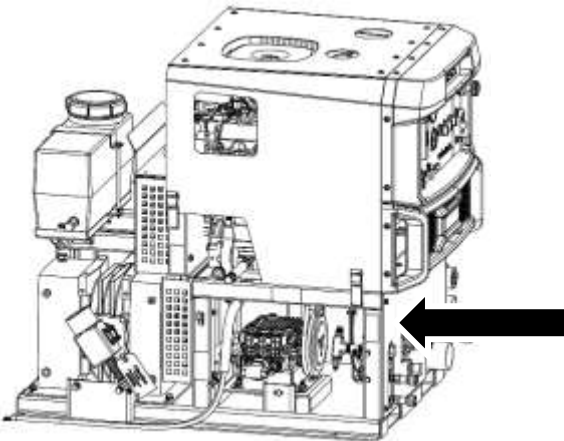

The **SAFETY** section contains important information regarding hazardous or unsafe practices for this machine. Levels of hazards are identified that could result in product damage, personal injury, or severe injury resulting in death.

The **INSTALLATION** section contains information on how to properly install the unit in your vehicle.

The **OPERATION** section is to familiarize the operator with the operation and function of the machine.

The **MAINTENANCE** section contains preventive maintenance to keep the machine and its components in good working condition.

The **PARTS LISTING & DIAGRAMS** section contains assembled parts illustrations and corresponding parts list. The parts lists include a number of columns of information:

NOTE: *If a service or option kit is installed on your machine, be sure to keep the KIT INSTRUCTIONS which came with the kit. It contains replacement parts numbers needed for ordering future parts.*

SAFETY

The following warning labels are on your mobile cleaning unit. These labels point out important **WARNINGS** and **CAUTIONS**, which must be followed at **ALL** times. Failure to follow these warnings could result in injury or fatality to yourself and/or others or property damage. Please follow these instructions carefully! **DO NOT remove these decals.**



WARNING

Legend Brands uses this WARNING symbol throughout the manual to warn of the possibility of physical injury or fatality. Please read all warnings carefully before operating the equipment.

CAUTION

Legend Brands uses this CAUTION symbol throughout the manual to warn of the possibility of damage to equipment or personal property.

 **WARNING**

1. **Read the operator's manual before starting this unit.**
Failure to adhere to instructions could result in severe personal injury or could be fatal.
2. **Operate your vehicle and equipment in a well-ventilated area.**
Exhaust fumes contain carbon monoxide, which is an odorless and deadly poison that can cause severe injury or death. **DO NOT** run the vehicle in an enclosed area. **DO NOT** operate this unit where the vehicle exhaust may enter a building doorway, window, vent or other opening.
3. This unit must be operated with the vehicle doors open in order to ensure adequate ventilation to the engine.
4. **Gasoline is extremely flammable and its vapors can explode if ignited.** Store gasoline only in approved containers, in well-ventilated, unoccupied buildings and away from sparks or flames. Never carry gasoline or any flammable materials in the vehicle. Fumes could accumulate inside of the vehicle and ignite, causing an explosion.
5. **DO NOT** operate unit if gasoline is spilled. Do not turn ignition switch until the gasoline has been cleaned up. Never use gasoline for cleaning purposes.
6. **DO NOT** place hands, feet, hair, clothing or any body parts near rotating or moving parts. Rotating machinery can cause severe injury or death.
7. **NEVER** operate this unit without belt and safety guards. High speed moving parts, such as belts and pulleys should be avoided while the unit is running. Severe injury, fatality and/or damage may result.
8. **NEVER** service a unit while it is running. High speed mechanical parts as well as high temperature components and fluids may result in severe injury or fatality.
9. Engine, vacuum pump and heat exchanger components, hoses and fittings will be extremely hot from operation. To prevent severe burns, **DO NOT** touch these areas while the unit is running, or shortly after the unit is shut off.
10. **DO NOT** touch any part of the exhaust system while the system is running, or for at least 20 minutes after the unit is shut off. Severe burns could result.
11. **Water under pressure can cause severe personal injury or fatality.** Shut down unit, allow to cool down, and relieve system of all pressure before removing caps, valves, plugs, fittings, filters or hardware.
12. **NEVER** leave the vehicle engine running while the unit is in operation.

SECTION ONE: GENERAL INFORMATION

13. Battery acid contains sulfuric acid. To prevent acid burns, avoid contact with skin, eyes and clothing. Batteries also produce explosive hydrogen gases while charging. To prevent fire or explosion, charge batteries only in a well ventilated area. Keep sparks, open flames, as well as other sources of ignition away from battery at all times. Remove all jewelry prior to servicing batteries. Keep batteries out of the reach of children.

Before disconnecting the negative (-) ground cable, ensure that all switches are in the off position. If on, a spark could occur at the ground connection terminal which could cause an explosion if hydrogen gas or gasoline vapors are present. ALWAYS disconnect the negative (-) terminal first

14. DO NOT smoke around the vehicle. Gas fumes could accumulate and ignite. Battery gasses are extremely flammable. This will prevent possible explosions.

15. NEVER cut or splice any of the vehicle fuel lines during fuel line installation. This could result in fuel leaks and potentially dangerous conditions. Use only the provided fuel hose for fuel lines. When going through the vehicle floor with fuel lines, always utilize bulkhead adaptors. This will prevent fuel leaks and ensure that hoses are not punctured by vehicle vibration abrasion.

16. All high-pressure hoses must be rated to 250° F and 3000 PSI. Severe injuries may result from improper hoses.

17. The Occupational and Health Administration (OSHA) recommends the use of hearing protection when a technician is exposed to an average of 85 decibels (this is an average of exposure over an 8 hour period). This equipment can produce 85 decibels at a distance of 10 feet. Please check with your local state agencies to see if OSHA standards apply to your application.

18. This unit produces high solution pressure. Improper use could result in injury.

19. California Proposition 65 Warning: Engine exhaust from this product can expose you to chemicals, including carbon monoxide, which is known to the State of California to cause birth defects or other reproductive harm. For more information go to www.P65Warnings.ca.gov.

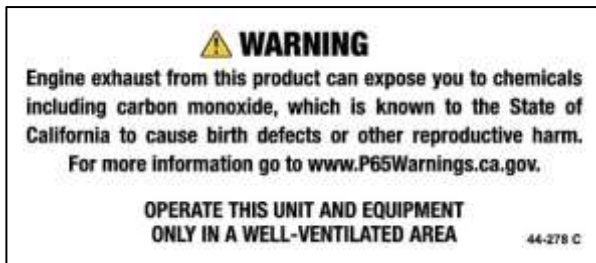

44-278

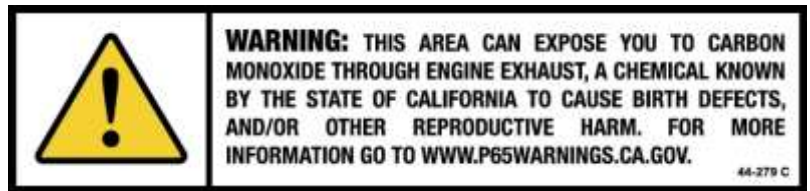

44-279

NOTE: Any unit entering the State of California must properly display Proposition 65 warning labels. Legend Brands label 44-279 has been included and must be installed on the vehicle or enclosure where a unit has been installed in a clearly visible location. Legend Brands label 44-278 must be installed on the unit in a clearly visible location. If you are in California and do not see one or both of these labels installed or need a replacement, contact Legend Brands immediately.

 **CAUTION**

1. **DO NOT** operate this unit at angles exceeding 25 degrees in any direction. Always try to keep the unit as level as possible during operation.
2. **DO NOT** damage the vehicle in any way during the installation. Avoid component or hose contact with moving parts, hot surfaces, brake lines, fuel lines, catalytic converters, exhaust pipes, mufflers, rotating parts or sharp objects.
3. **DO NOT** exceed the vehicle's payload capacity. This will prevent unsafe or hazardous driving conditions. Before installing any components into the vehicle, check with the vehicle manufacturer for the Gross Vehicle Weight Rating (GVWR). GVWR is the maximum allowable combined weight of the vehicle, including all passengers, fuel, fluids, tools and cargo.

Example: If the GVWR for a vehicle is 9600 lbs. and the vehicle has a base curb weight of 6400 lbs., this leaves a payload capacity of 3200 lbs. (GVWR - Curb Weight = Payload Capacity).

4. Always keep your vehicle clean and orderly. Tools and accessories must be securely stowed while driving the vehicle.
5. Ensure that you have received proper training and are familiar with the start-up and shut-down procedures prior to operation.
6. **DO NOT** alter or modify your **Peak 500** in any way. Use only replacement parts authorized by **Legend Brands**. Modifications or use of unapproved parts could create a hazard and will void your warranty. This includes the use of any open ended hoses.
7. Failure to apply preventative measures towards freezing can result in system failure and loss of warranty on affected parts. Water freezes at 32° F and 0° C.

READ AND SAVE THESE INSTRUCTIONS

SPECIFICATIONS

Engine Speed	3000 RPM (High Speed/No Load) 1500 RPM (Idle/No Load)
Water Pump	1500 RPM (High Speed)
Water Pump Flow Rate	3.5 GPM (Maximum)
Water Pump Pressure	1500 PSI (Maximum)
Vacuum Pump	3402 RPM (High Speed)
Vacuum Relief Valve	13 in. Hg
Standard Waste Tank Capacity at Shut-Off	75 gallons
Standard Waste Tank Gross Capacity	90 gallons
Console Weight	714 lbs. (dry)
Standard Install Package Weight	1028 lbs. (dry)
Standard Operating Weight	1680 lbs. (includes water weight, not accessories)

TORQUE VALUES

Engine front pulley 5/16" screws	180 in. lbs. / 15 ft. lbs.
Engine front pulley adapter 8mm bolts	275 in. lbs. / 23 ft. lbs.
Engine drive pulley hub 1/4 screws	160 in. lbs. / 13 ft. lbs.
Engine exhaust 8mm nuts	180 in. lbs. / 15 ft. lbs.
Engine oil drain fitting	215 in. lbs. / 18 ft. lbs.
Vacuum pump pulley hub 1/4 screws	160 in. lbs. / 13 ft. lbs.

Refer to component manufacturer documentation for more information

BELT TENSIONS (NEW BELTS)

Gates Tri-Power EPDM AX Belt	4 – 6 lbs. @ 7/32" Deflection
Gates Tri-Power EPDM BX Belts	8 – 11 lbs. @ 3/16" Deflection

BELT TENSIONS (RETENSIONED BELTS)

Gates Tri-Power EPDM AX Belt	3 – 4 lbs. @ 7/32" Deflection
Gates Tri-Power EPDM BX Belts	5 – 8 lbs. @ 3/16" Deflection

JET SIZING

Legend Brands recommends that the total floor tool tip size be #6

LAYOUT WITH 90 GALLON WASTE TANK (IN INCHES)

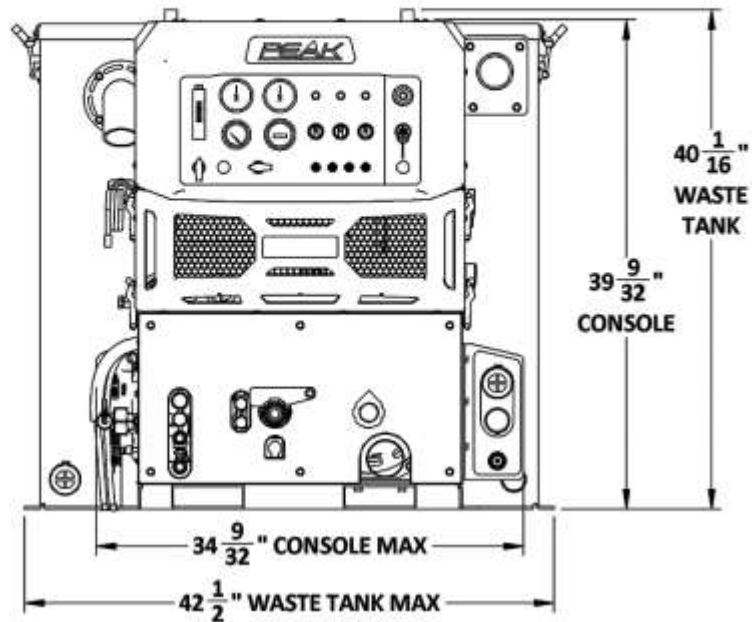
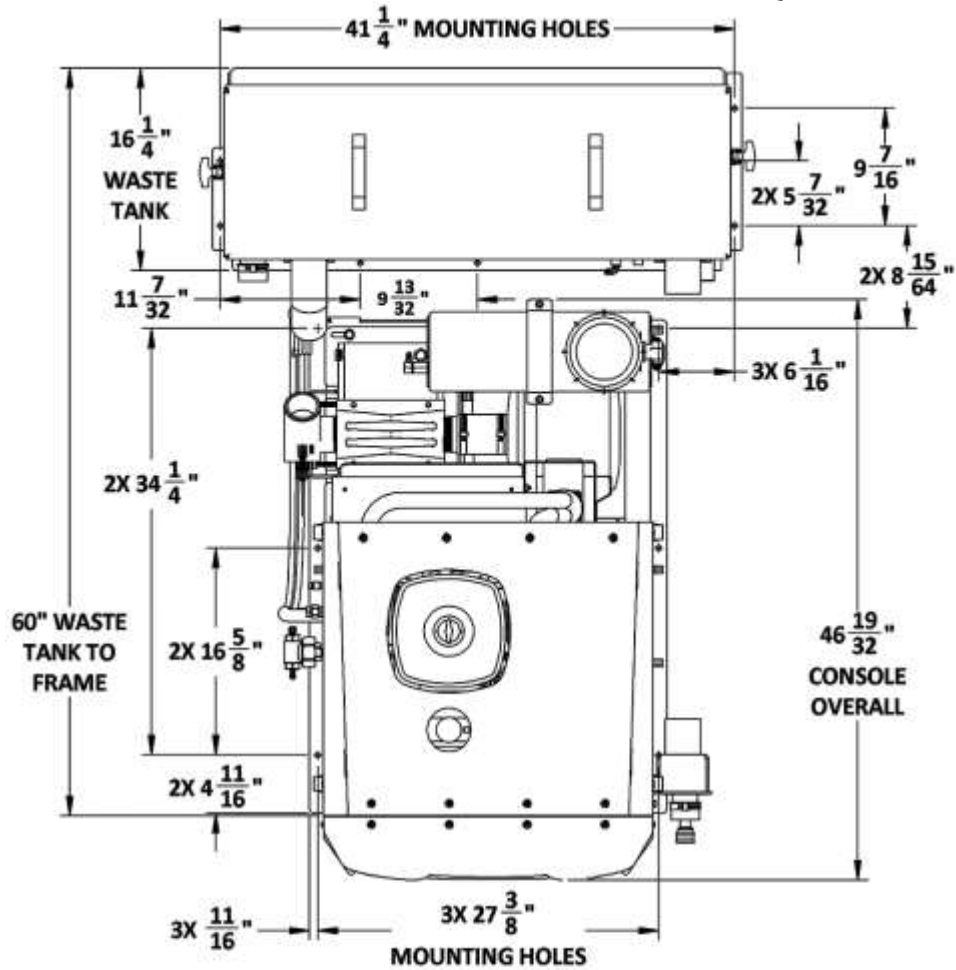

SECTION ONE: GENERAL INFORMATION

LAYOUT WITH 120 GALLON WASTE TANK (IN INCHES)

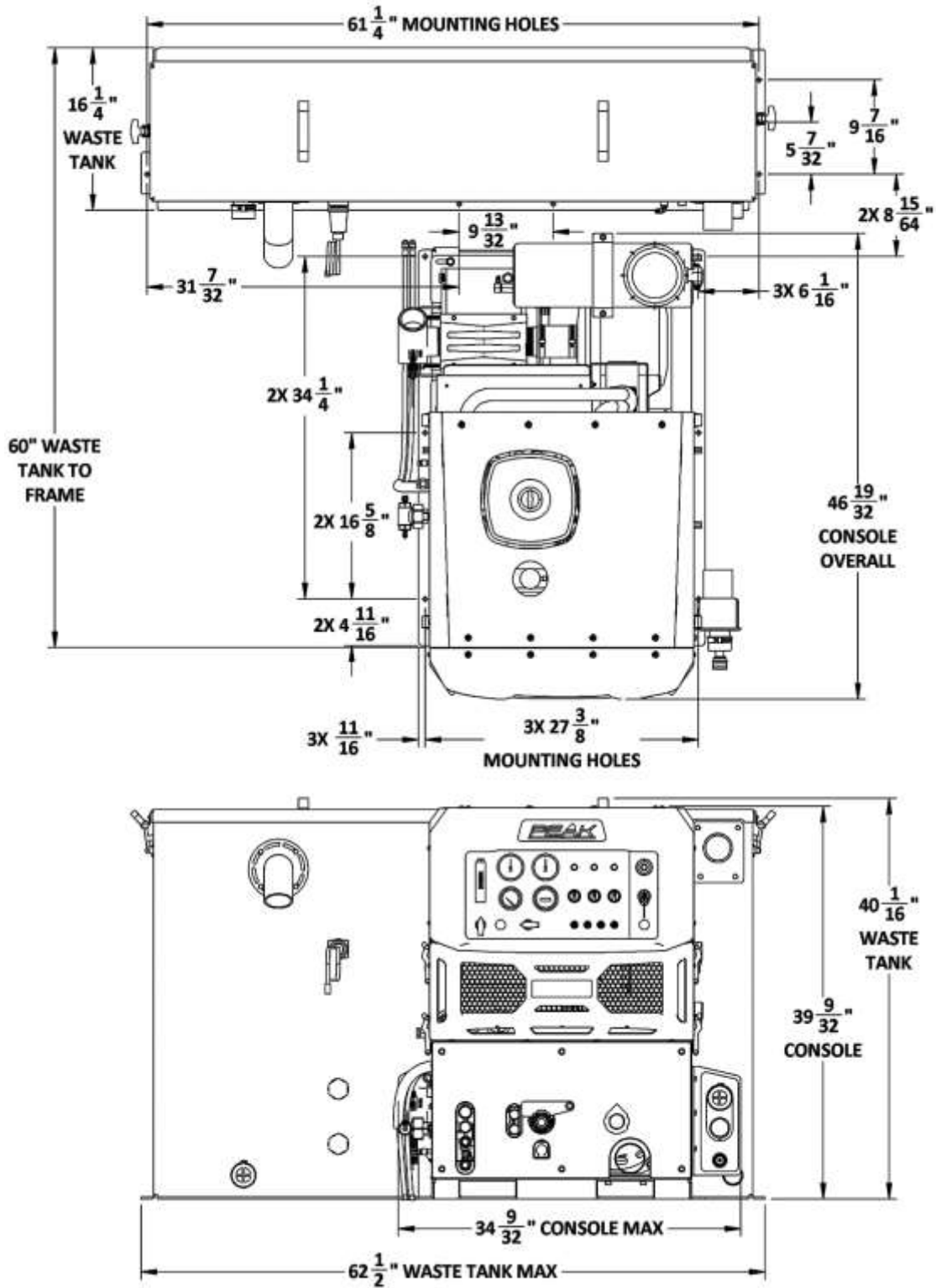

INSTALLATION REQUIREMENTS

Prior to beginning the installation, read the **ENTIRE** "Installation" section of this manual. Due to the weight of the Peak 500, please adhere to the following recommendations prior to installing the unit.

1. The unit should **NOT** be installed in any motor vehicle rated less than 3/4 ton capacity.

CAUTION!

DO NOT exceed the vehicle's payload capacity. This will prevent unsafe or hazardous driving conditions. Before installing any components into the vehicle, check with the vehicle manufacturer for the Gross Vehicle Weight Rating (GVWR). GVWR is the maximum allowable combined weight of the vehicle, including all passengers, fuel, fluids, tools and cargo.

2. If mounting the unit in a trailer, ensure that the trailer is rated for the total weight of the unit and trailer. Electric or hydraulic brakes must be provided, and strict compliance with all State and Federal laws must be maintained.
3. If mounting in a trailer, the Peak 500 console must be positioned so that it balances properly with respect to the trailer axle. Ten percent (10%) of the unit's total overall weight (w/o accessories or water) should be on the tongue. This unit has an air cooled engine, and adequate ventilation must be provided to prevent overheating.
4. Legend Brands does not recommend using any type of flooring materials that absorb water. This condition will result in rust and corrosion of the vehicle floor.
5. Insulation under rubber mats should be removed prior to installation of the unit.

FUEL REQUIREMENTS

Use unleaded fuel ONLY. Use only fresh, clean unleaded gasoline with a minimum octane rating of 87. **Do Not** use high octane gasoline.

Oxygenated fuels:

- Unleaded gasoline with up to, not exceeding, 10% ethanol by volume is acceptable.
- Unleaded gasoline with up to, not exceeding, 15% MTBE by volume is acceptable.

NOTE: Using other gasoline/alcohol blends including E20 and E85 will cause damage to engine components and will void warranty.

ENGINE REQUIREMENTS

Use high-quality oil of at least API (American Petroleum Institute) service class SG or higher. **Do not use additives.**

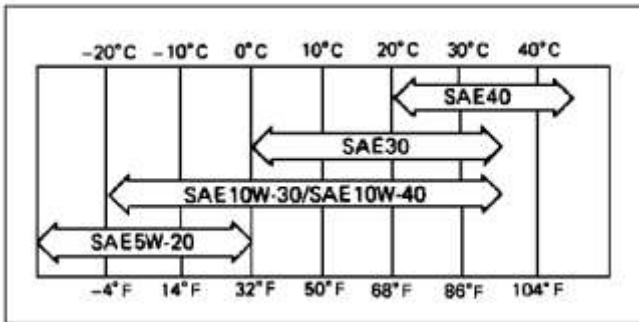

High quality 20W-50 oil is recommended in extreme hot climates due to ambient temperature increase inside the vehicle during operation. See the maintenance section for recommended schedules.

Engine Oil Capacity	1.8 L / 1.9 US qt when oil filter is not removed
	2.0 L / 2.1 US qt when oil filter is removed
Coolant Capacity	2.7L / 2.9 US qt

CHEMICAL REQUIREMENTS

The **LEGEND BRANDS Peak 500** Truck mount unit's unique last step chemical injection system can be used with a wide variety of water diluted chemical compounds, either acidic or alkaline, depending on the work to be performed. We recommend using only **LEGEND BRANDS** brand chemistry.

WATER REQUIREMENTS

Because hard water deposits will damage the plumbing and heat exchange systems on this unit, Legend Brands recommends that a high quality water softener be used in areas where the water hardness exceeds 3½ grains. If a water softener is used, it must have a flow capacity of at least five (5) GPM or greater, without any hose constrictions.

The use of a water softening system will reduce maintenance and reduce down time caused by hard water scaling. It will also enhance the performance of cleaning chemicals, which will result in greater efficiency in lower concentrations.

See the chapter in Section 3 of this manual for instructions on descaling your system.

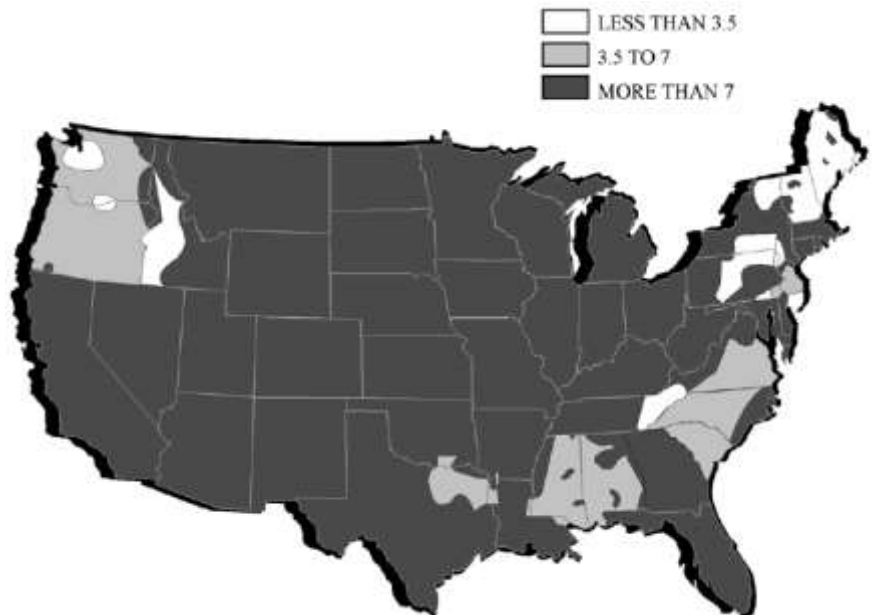

RECEIVING YOUR TRUCK-MOUNT UNIT

DEALER RESPONSIBILITIES

The Legend Brands authorized dealer that you purchased this unit from is responsible for:

1. Correctly installing and properly securing equipment with proper hardware and underside mounting plates.
2. Checking the components and oil levels prior to starting the unit.
3. Checking that all components are operating at the factory specification.
4. Checking all hoses and accessories for correct operation.
5. Checking all tools/wands for correct operation.
6. Training you in the operation, maintenance and safety precautions of your unit.

It is the purchaser's responsibility to become familiar with the entire Owner's Manual, most importantly all Warnings, Cautions and Notices.

ACCEPTANCE OF SHIPMENT

Your Peak 500 cleaning unit was thoroughly tested, checked and inspected in its entirety prior to leaving our manufacturing facility. When receiving your unit, please make the following acceptance check:

1. The unit should not show any signs of damage. If there is damage, notify the deliverer immediately.
2. Carefully check your equipment. The Peak 500 should arrive with the following items as well as any additional optional accessories you may have ordered:

EQUIPMENT LISTING

- Legend Brands Peak 500 console
- Recovery tank with shut-off switch and inlet/outlet ports, gaskets and hardware
- Recovery tank vacuum and drain hoses and clamps
- Operation and Service Manual
- Installation mounting plates and hardware
- Prop 65 Label and instructions for units operating in California
- Recovery tank mesh filter and stainless steel strainer basket
- Fuel pump and filter installation kit
- 50 ft. of 1/4-inch high pressure solution hose with shutoff valve and quick connects
- 50 ft. of 1/4-inch high pressure solution hose with quick connects
- 100 ft. of 2-inch vacuum hose
- 50 ft. water supply hose with quick connect
- 2-inch vacuum hose coupler
- Group 24 battery box
- Five gallon chemical jug and holder

OPTIONAL EQUIPMENT

- 50 ft. 2-inch vacuum hose
Part No. 18-003
- 50 ft. 2-1/2-inch vacuum hose
Part No. 18-333
- 2-inch vacuum hose coupler
Part No. 21-003
- 50 ft. high-pressure solution hose with
qd fittings (no valve)
Part No. 18-000
- 100 ft. high-pressure solution hose w/valve
and qd fittings
Part No. 18-250
- 50 ft. water hose w/qd fitting
Part No. 18-002
- Automatic waste pump kit
Part No. 68-158
- Demand pump system
Part No. 68-190

FUEL HOOK-UP KITS BY VEHICLE

- Chevy 1997 to 2002 FI 69-003FI
- Chevy 2003 FI 69-018FI
- Chevy 2004+ Hook-Up Kit 69-033
- Chevy Box Truck 2004+ 69-081
- Dodge 1997 to 2002 FI 69-004FI
- Ram ProMaster 69-613S
- Ford FI 69-005FI
- Ford 2004 – 2010 69-061
- Ford 2011+ 69-331
- Ford Box Truck 2004+ 68-077
- Ford Transit 2014+ 69-671
- Nissan NV 69-376

SECTION TWO: INSTALLATION

WARNING!!!

This unit must be bolted to the floor of the vehicle by an authorized LEGEND BRANDS DISTRIBUTOR.

LIFTING THE UNIT INTO THE VEHICLE

Because the console weighs 714 lbs., a forklift is necessary to place the unit into the vehicle. Position the forks under the unit from the front and make certain that the forks are spread to insert into the frame slots.

POSITIONING THE UNIT INTO THE VEHICLE

Vehicles vary in size and openings. Owners have different preferences on where in the vehicle they want their units positioned. Legend Brands strongly recommends a side door installation for the Peak 500. We do NOT recommend a rear door installation.

1. Ensure that enough space is provided to assure adequate engine ventilation as well as room for service and maintenance.

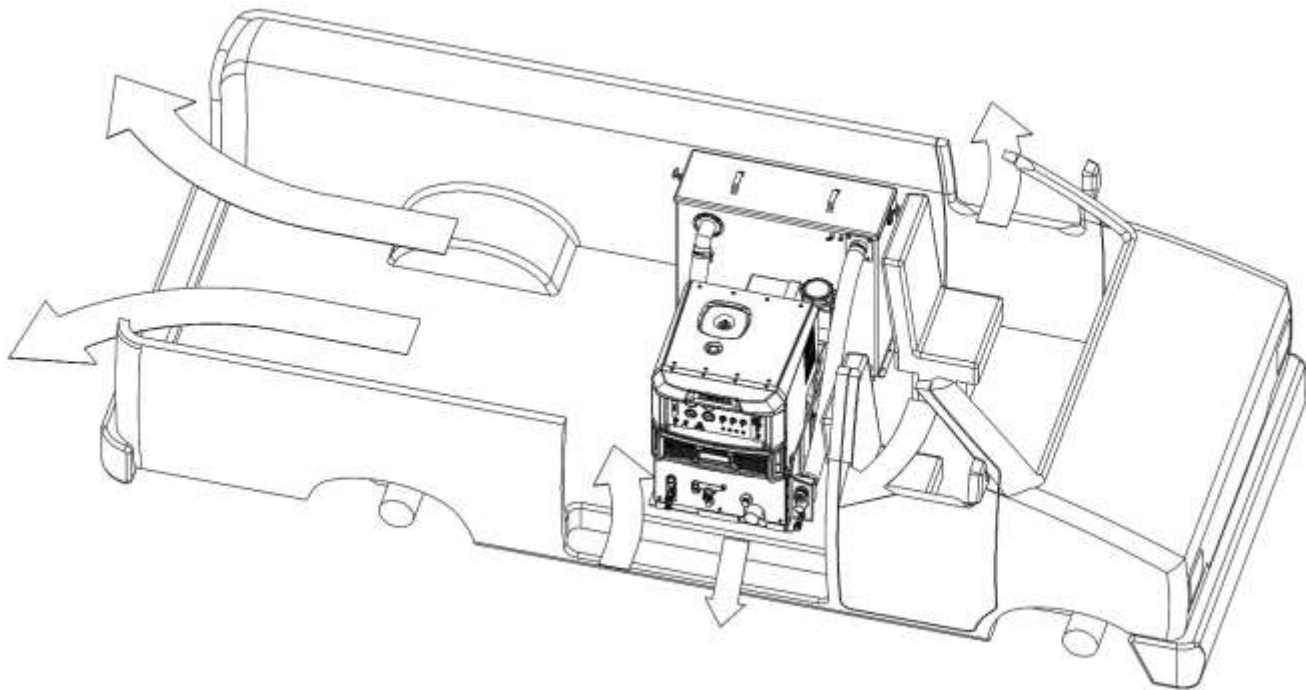

2. Operating weight of the complete installation (which includes water weight) with waste tank and ALL accessories MUST NOT exceed the vehicle's axle weight limit. Please refer to SPECIFICATIONS in Section One for standard unit and waste tank operating weight.

FASTENING DOWN THE UNIT AND WASTE TANK

CAUTION

Prior to drilling any holes in the vehicle floor, ensure that while drilling, you will not damage the fuel tank, fuel lines, or any other vital components which could affect the safety or operation of the vehicle.

A. The console mounting rails and waste tank mounting holes will serve as a template. Drill eight (8) to ten (10) $\frac{13}{32}$ in. diameter holes for the console and six (6) to eight (8) $\frac{13}{32}$ in. diameter holes for the waste tank.

B. Using the provided mounting hardware kit:

Insert grade 5, 3/8-16 x 4 in. hex head cap screws with flat washers through the console and waste tank mounting holes. The two 5/16-18 x 6 in. hex head cap screws are provided if the unit is being installed into a Ford Transit. See your Transit installation guide for more information.

Install the provided mounting plates underneath the vehicle floor. Use the larger plates where space is available.

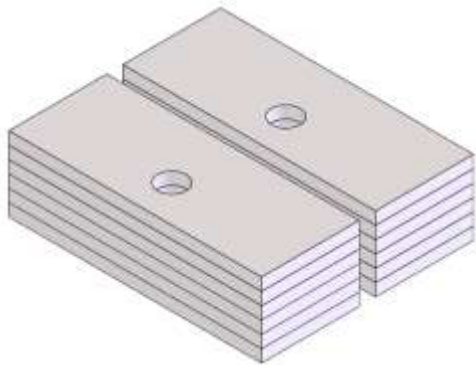

Screw the provided 3/8-16 hex head lock nuts on to the mounting bolts and tighten until the console and waste tank are firmly attached to the vehicle floor.

 **WARNING!** Do not alter or modify your **unit** in any way. Use only replacement parts authorized by **Legend Brands**. Modifications or use of unapproved parts could create a hazard and will void your warranty. Contact your authorized Legend Brands dealer for assistance.

INSTALLATION OF FUEL LINES

⚠ WARNING! The Vehicle fuel lines should NOT be spliced under ANY circumstances. Severe injury or fatality could result.

- When routing fuel lines, DO NOT configure the hoses in any location where the hoses, or vehicle could be damaged.
- All fuel lines must meet CARB TIER III and EPA PHASE 3 low permeability requirements.
- Avoid contact with moving parts, areas of high temperature, brake lines, fuel lines, catalytic converters, exhaust pipes, mufflers or sharp objects.
- Fuel pump must be mounted in a horizontal position as near as possible to the fuel supply, and not located near any heat sources.
- Excess heat from exhaust or other heat sources may cause the fuel pump to work improperly.

FUEL LINE IDENTIFICATION

The Peak return fuel line routes all the way to the engine from the fuel source. The first step is to identify which fuel line is for incoming fuel and which is the return line. The incoming fuel line starts on the top rear of the engine and routes directly to the fuel manifold in the frame. The return line routes from the engine interior to a joint fitting and then to the fuel manifold in the frame. See the diagram for a visual explanation.

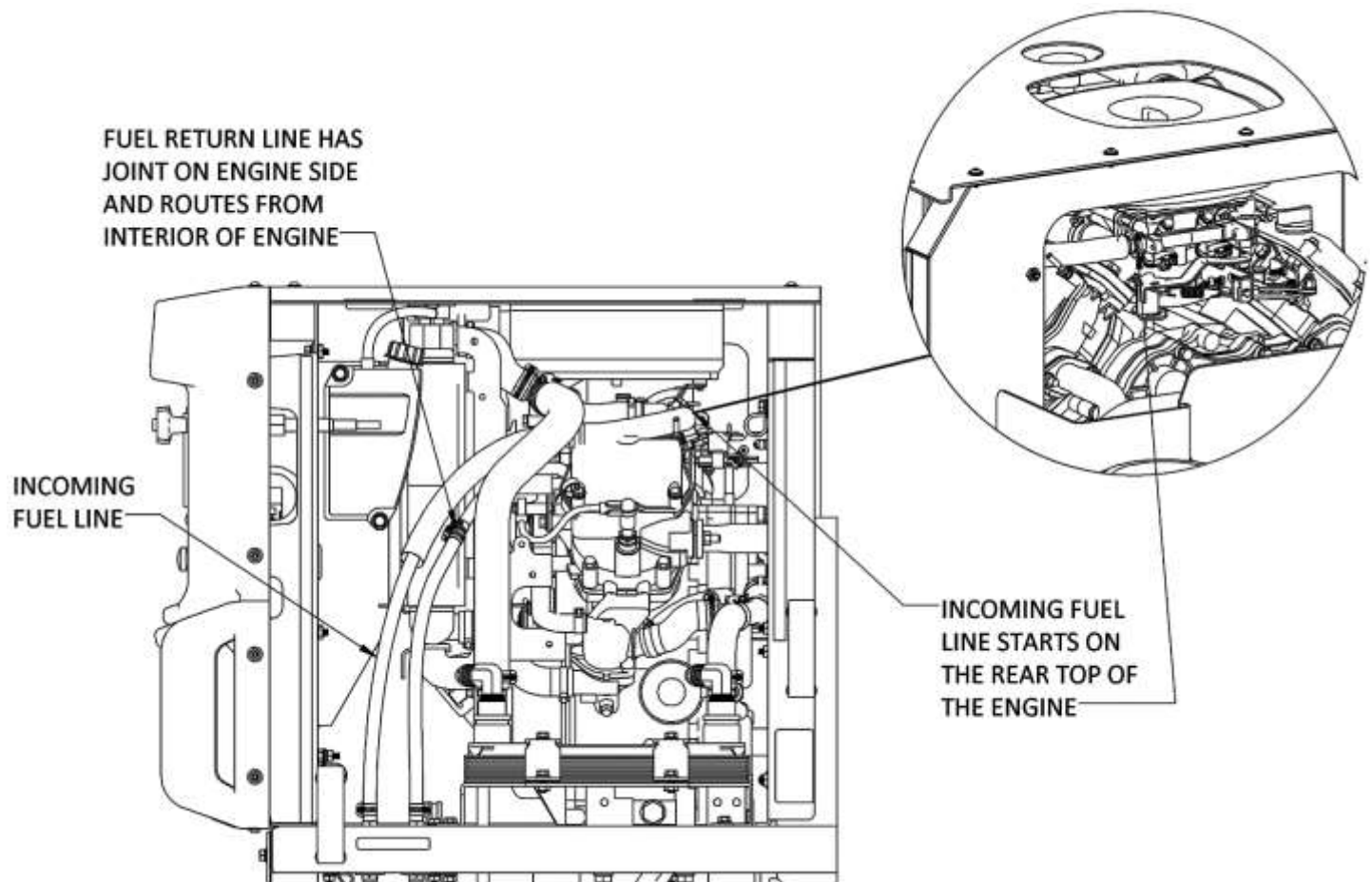

FUEL LINE BULKHEAD INSTALLATION

1. Inside the vehicle, select an appropriate location on the vehicle floor away from operator or maintenance traffic and away from contact with any accessories or tools while in use or transit. Make sure your location is within adequate reach of your supply of fuel hose from the fuel manifolds in the finished assembly. The majority of your return line needs to be outside the vehicle for proper fuel temperature management. If your bulkhead fitting is too close to the fuel cell, wind several feet of return line under the vehicle.
2. Drill two 3/4 inch holes through the vehicle floor at the location chosen for the bulkhead connectors.
3. Install each bulkhead connector by inserting the fitting and tightening the nut and lock washer on the opposite side of the vehicle floor.
4. Inside the vehicle, attach each hose barb fitting and connect the fuel lines from the console fuel manifolds. Hose clamps have been provided on the frame for routing the fuel hoses in a safe and clean manner. Be sure to correctly identify the incoming fuel line from the return line at the bulkhead fittings.
5. Drill a 1-1/4 inch hole (or a slot 3/4 x 1-1/4 – large enough to pass the connector through) nearby the bulkhead fittings for the fuel pump electrical extension harness to pass through.

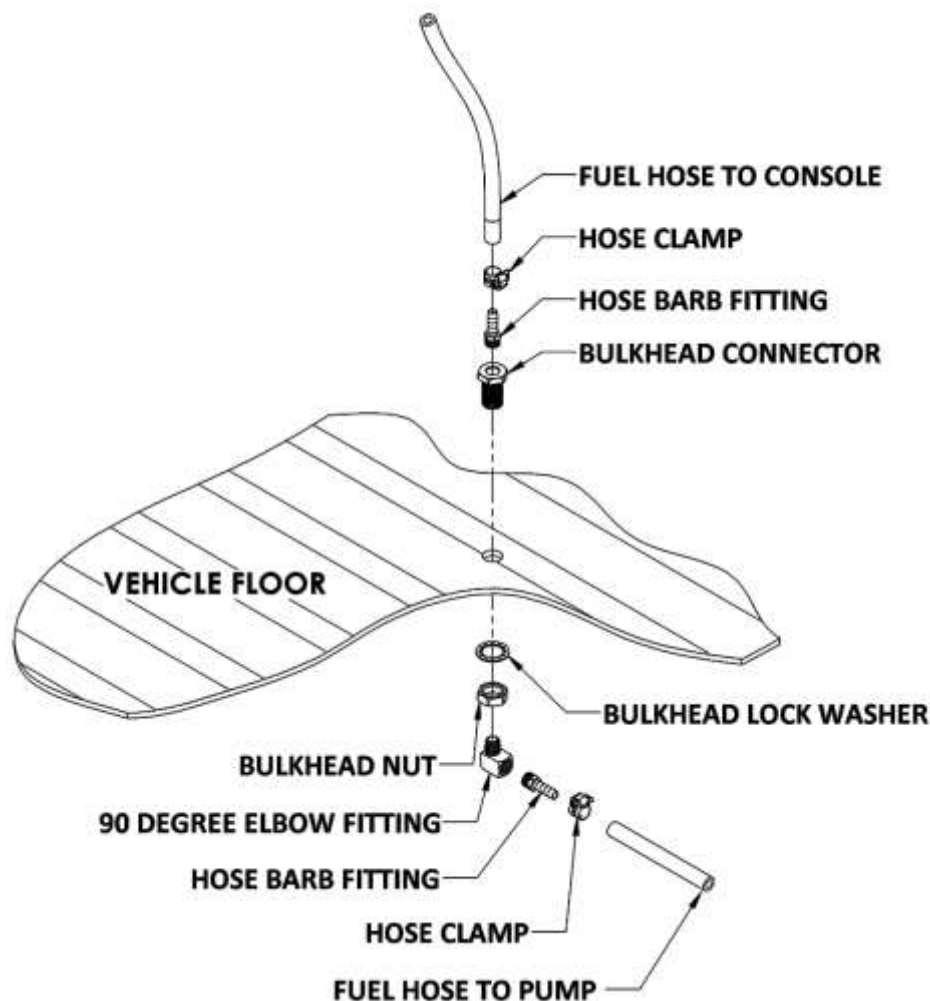

FUEL PUMP ASSEMBLY INSTALLATION

Locate an appropriate location for the fuel pump assembly housing to mount underneath the vehicle that will not cause damage to the vehicle or compromise the fuel line routing or components.

Remove the housing lid from the fuel pump assembly.

Use the supplied Tek screws to install the lid of the fuel pump housing to the vehicle.

NOTE: Install the fuel pump assembly close to the fuel source.

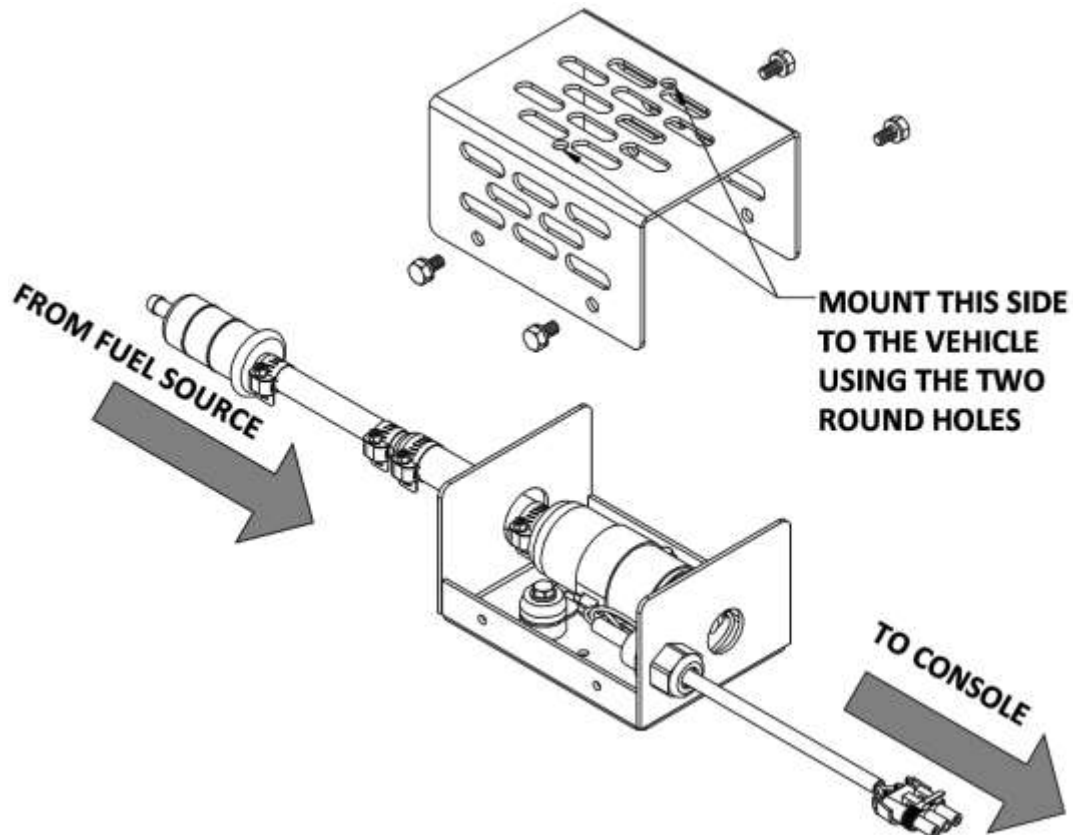

SECTION TWO: INSTALLATION

FUEL SUPPLY & RETURN LINE INSTALLATION

Refer to the transfer flow kit instructions found with the appropriate kit for your vehicle.

1. Connect the fuel line from the transfer flow kit to the inlet side of the fuel pump.
2. Connect the outlet side of the fuel pump to the bulkhead fitting.
3. Connect the return line from the bulkhead fitting to the fuel cell
4. Connect the check valve inline in the return line near the fuel cell (if not already installed).
5. Ensure that all hose clamps are properly tightened.

NOTE: The return fuel line needs to have enough length outside the vehicle in order to properly cool the fuel temperature. Do not install bulkhead fittings too close to the fuel cell.

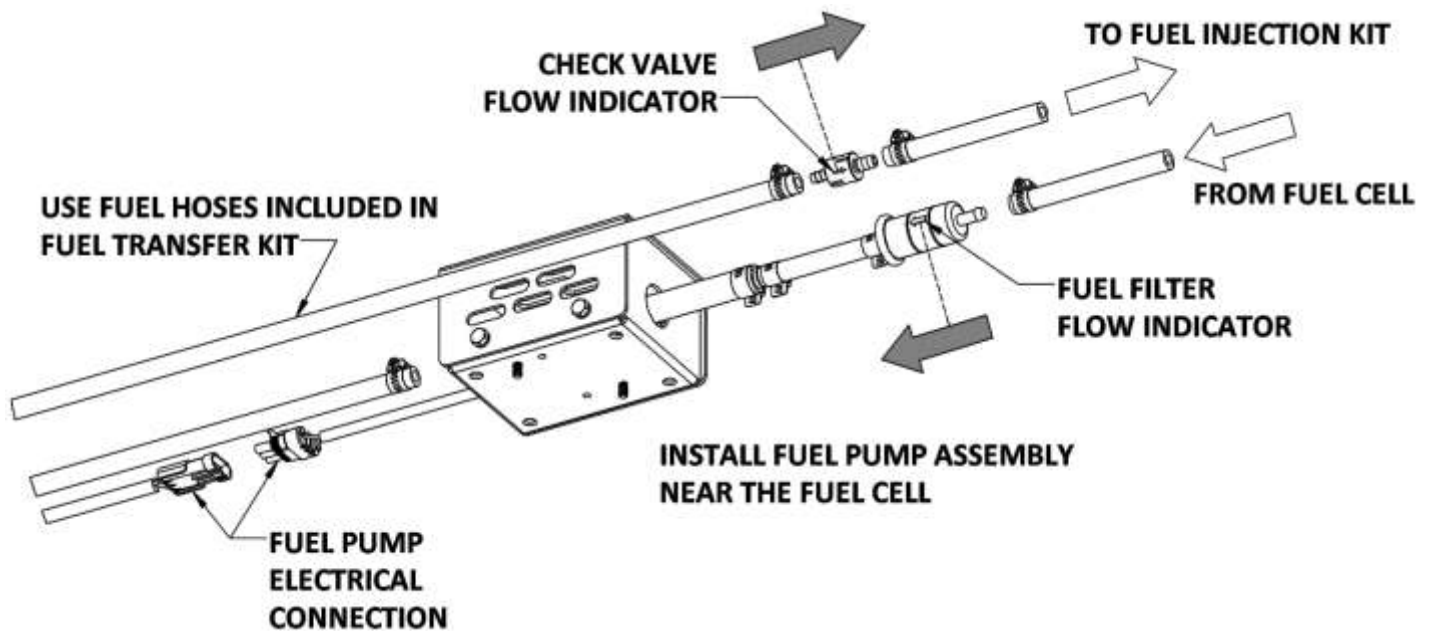

NOTE: The fuel pump and filter are provided with the engine. Legend Brands does not recommend using non OEM parts. Using non OEM parts may damage critical components. Contact Legend Brands for OEM replacement parts:

36-596, PUMP, FUEL 49040-2079

36-639, FILTER, FUEL 49019-1055

36-638, JOINT, FUEL 59071-2141

SECTION TWO: INSTALLATION

- The electrical extension harness connects to the console wiring harness on the left side of the unit, near the engine oil drain. Run the extension harness through the hole in the floor and connect to the fuel pump harness.
- Secure all lines tightly and carefully, avoiding contact with any sharp edges. Use industrial zip ties, protective sleeves and grommets as necessary to shield exposed fuel hoses and wiring.

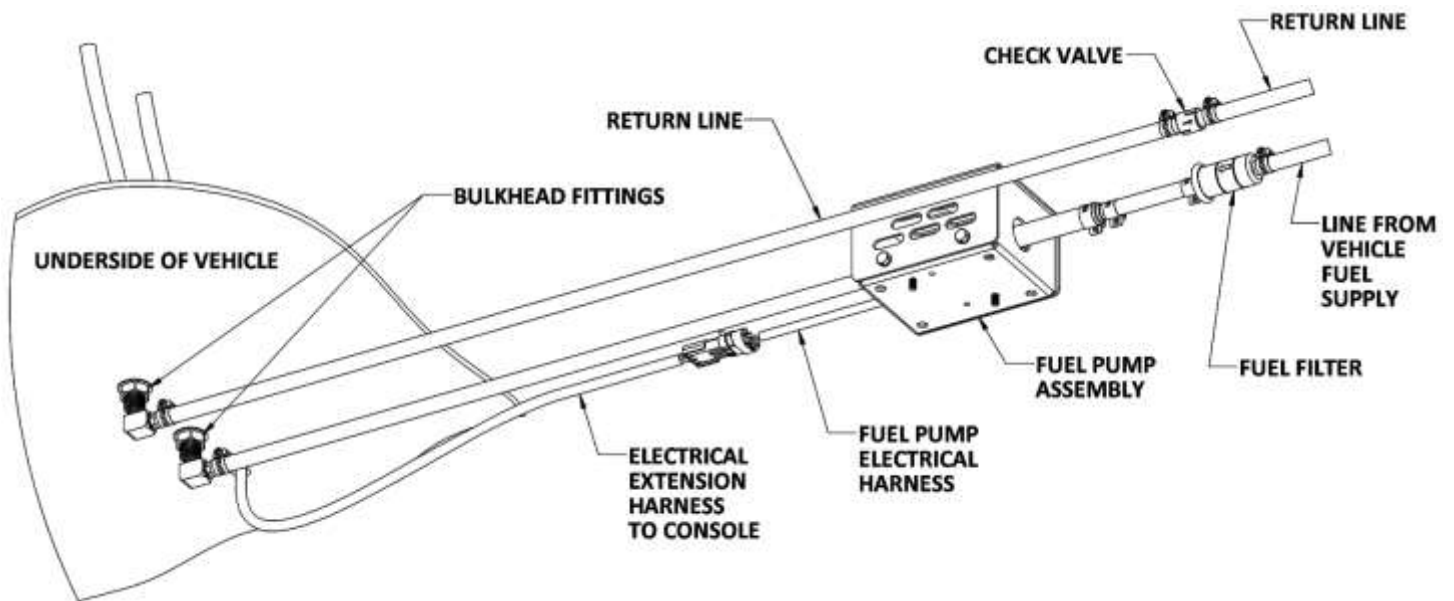

TRAILER FUEL TANK AND FUEL LINE INSTALLATION

The following are recommendations for trailer installations:

- Strict compliance with all federal and state laws must be maintained. **Tanks must meet CARB TIER III and EPA PHASE3 permeation and venting emissions requirements.**
- Use only fuel tanks that are manufactured specifically for gasoline, have proper vented filling caps, and outlet connections that are the same size as the inlet and return connections on the unit.
- **DO NOT** install fuel tanks inside any type of enclosed trailer or vehicle.
- **NEVER** carry gasoline or flammable materials in an enclosed trailer or vehicle.
- **NEVER** store any type of flammable material in an enclosed trailer or vehicle.
- Always mount fuel tanks where they will be protected from any vehicle collision.
- When installing fuel lines from the fuel tank to the unit, use the proper size fuel line.

BATTERY CONNECTION

WARNING!

Explosive gases, Dangerous gases!

Batteries contain sulfuric acid. To prevent acid burns, avoid contact with skin, eyes and clothing. Batteries also produce explosive hydrogen gases while charging. To prevent fire or explosion, charge batteries in a well-ventilated area only. Keep sparks, open flames, as well as any other sources of ignition away from batteries at all times. Remove all jewelry prior to servicing batteries. Keep batteries out of the reach of children.

- Before disconnecting the negative (-) ground cable, ensure that all switches are in the OFF position. If ON a spark could occur at the ground connection terminal, which could cause an explosion if hydrogen gas or gasoline vapors are present. ALWAYS disconnect the negative (-) terminal first.
- Attach the red positive (+) battery cable from the starter solenoid on the console to the positive (+) terminal on the battery and tighten down the nut.
- Attach the black negative (-) battery cable from the ground on the console to the negative (-) terminal on the battery and tighten down the nut.

FIRE EXTINGUISHER

Legend Brands, and many government agencies, recommend that a fire extinguisher rated for A, B, and C type fires be installed into any commercial vehicle.

INITIAL OPERATIONAL SETTINGS

NOTE: Due to temperature and altitude changes, the optimal setting for each truckmount must be adjusted after installation. Failure to make these adjustments may lead to poor unit performance and premature component failure.

VACUUM PUMP

The maximum vacuum pressure obtainable at full throttle should be 13”Hg. If the unit is drawing a stronger vacuum (at full sealed suction) than 13”Hg, adjust the vacuum relief spring until proper pressure is achieved.

ENGINE

Set RPM values as shown below. Refer to the engine operation manual for adjustment instructions.

THROTTLE	LOAD	RPM*
Idle	None	1450 RPM
Full	13”Hg. vacuum 500 PSI pressure	2850 RPM
Full	None	2950 RPM

*±50 RPM tolerance

CONSOLE TO WASTE TANK CONNECTIONS

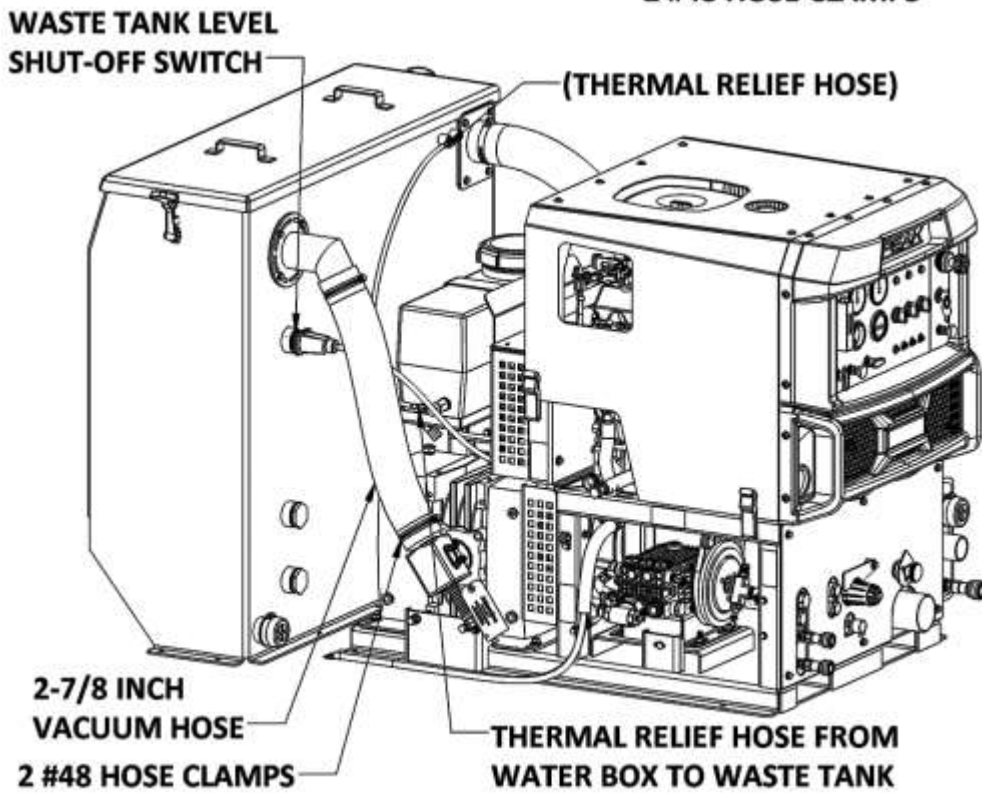
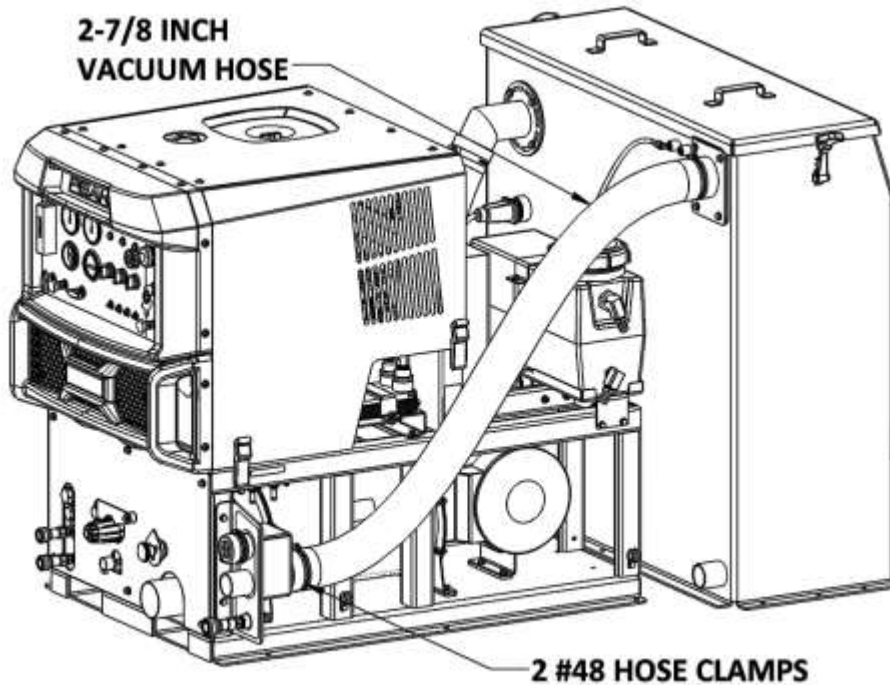

SECTION THREE: USING YOUR CLEANING SYSTEM

UNDERSTANDING THE SYSTEMS

NOTE: Read and understand this section of the manual entirely before proceeding.

This portion of the manual divides the unit up into systems and describes how each system works. Prior to proceeding into the operations and maintenance sections of this manual it is recommended that you acquire a basic understanding of how the unit functions.

WATER HEATING SYSTEM

Cold water enters the water box through the water inlet connection. When the water box is full, the internal valve with automatically shut off the water flow.

The water then flows to the water pump where it is sent to the pressure regulator which provides and maintains the desired pressure setting. A certain amount of water is bypassed from the regulator due to over pumping capacity of the water pump. The main bulk of water is directed to the engine coolant heat exchanger where the water is pre-heated before being sent to the exhaust heat exchanger. In the exhaust heat exchanger, water travels through a finned tube coil that is heated by the vacuum blower and engine exhaust.

The hot water then flows to the solution outlet manifold that contains a strainer and a check valve. A bypass valve on the control panel can be opened to deplete hot water when rapid cooling of the water temperature is desired.

When the cleaning tool is triggered, chemical is injected into the hot water stream inside the solution outlet manifold creating the hot solution that then flows directly to the cleaning tool.

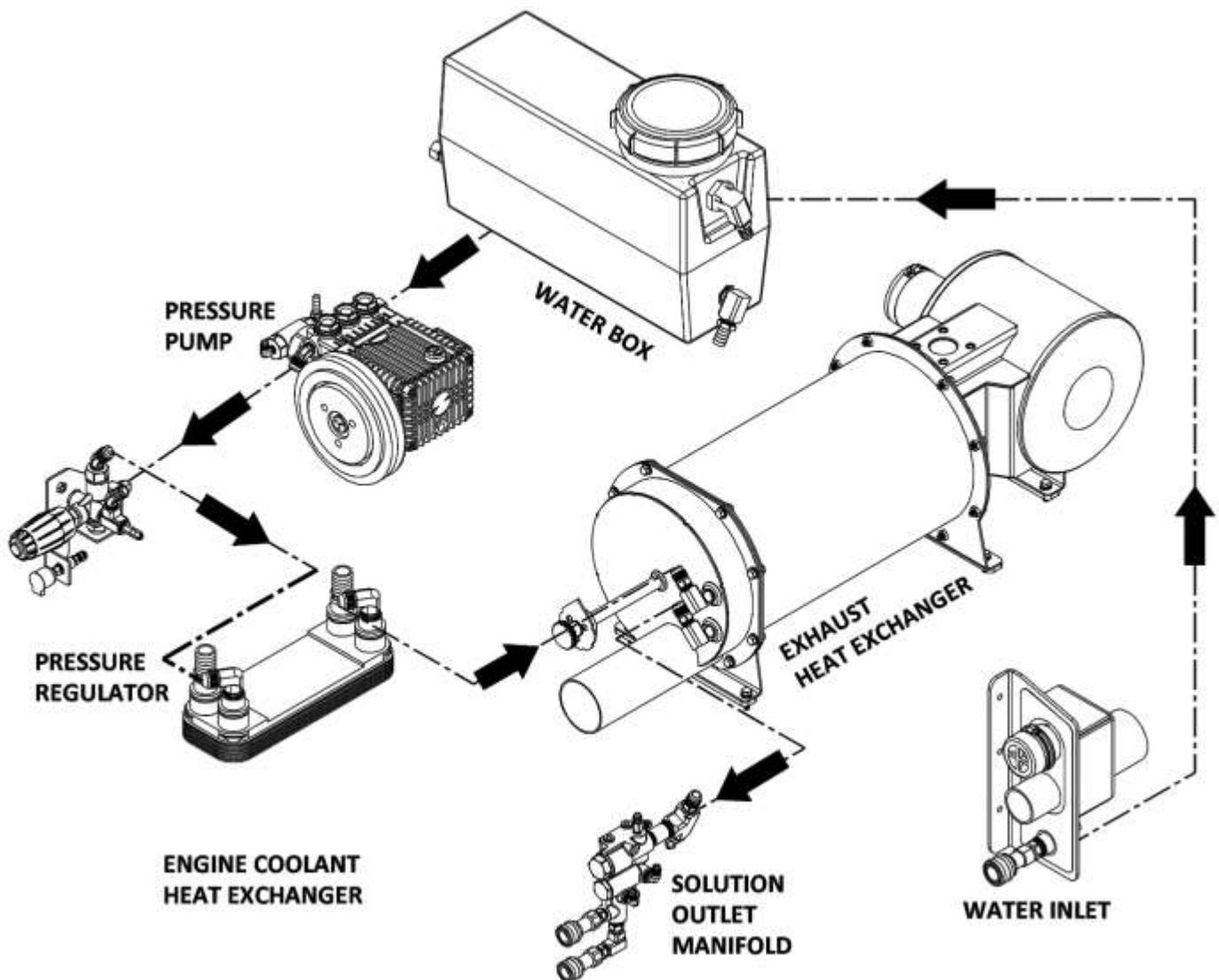

WATER TEMPERATURE CONTROL SYSTEM

The water temperature control dial and locking knob are located on the lower front panel of the unit with settings indicated for LOW, MED and HIGH heat. This temperature control uses a damper system to open or restrict exhaust flow through the core of the heat exchanger.

The control dial is locked into place with the locking knob. Turning the locking knob counterclockwise will release the dial to be freely adjusted. The locking knob may be warm if the unit has been running for more than 10 minutes.

Turning the knob counterclockwise towards the "LOW" setting opens the exhaust damper, allowing exhaust to evacuate the heat exchanger more quickly, reducing heat conduction in the coil. Turning the knob clockwise towards the "HIGH" setting closes the damper, slowing the exhaust as it passes over the heat exchanger coils, increasing heat generation.

NOTE: Always check the water temperature gauge before and during operation.

DO NOT leave the tool flat on a surface when sitting idle with the unit running. This will cause unnecessary strain on the unit and build excessive heat in the water.

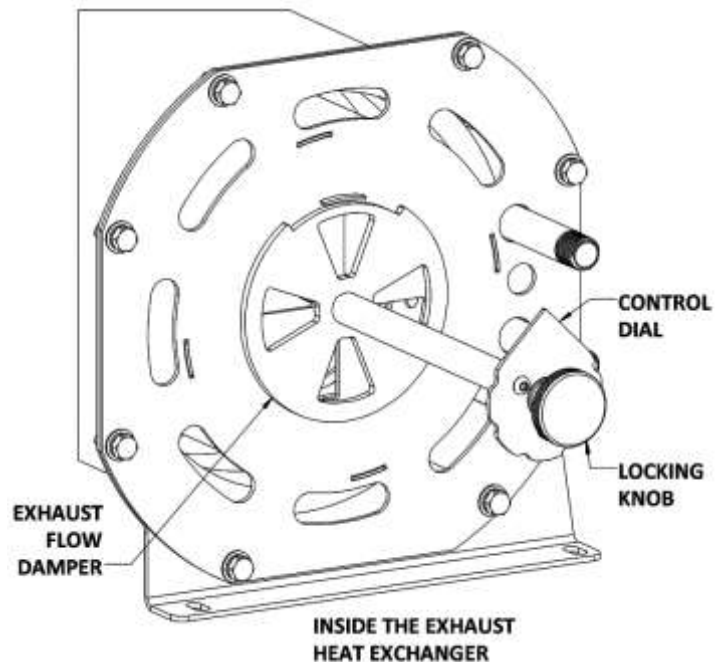
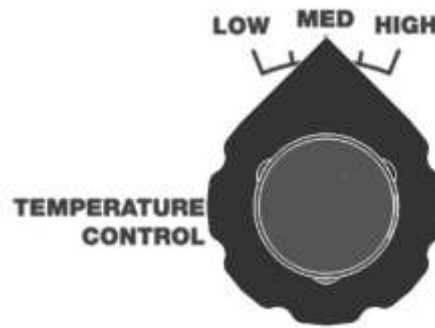

VACUUM SYSTEM

The engine turning a vacuum pump generates the vacuum. The air is channeled in one side of the vacuum pump, compressed and discharged on the opposite side, creating airflow. This airflow is used to do the work necessary for the extraction process. A vacuum nozzle applied to the carpet surface removes moisture, dirt and spent chemicals. These elements are conveyed back to a recovery tank utilizing hoses and the force of air. Particles of moisture and dirt are separated in the recovery tank using a series of changes in direction and velocity. The air is then filtered and rushes into the vacuum pump.

The vacuum pump also heats incoming air as it is compressed. The hot discharged air is forced into a silencer for noise abatement. Exiting the silencer, this hot air is directed through the heat exchanger

The vacuum pump speed is factory set to maximize vacuum pressure and provide sustained system life. Do not alter the vacuum speed outside the recommended range shown in the Specifications section.

A level shut off sensor is located near the top of the waste tank and will shut down the unit before the tank is at full capacity. This protects the vacuum pump from water damage. Note: Waste tank level shut off will not shut the unit off due to high levels of foam. The use of a quality de-foamer is recommended.

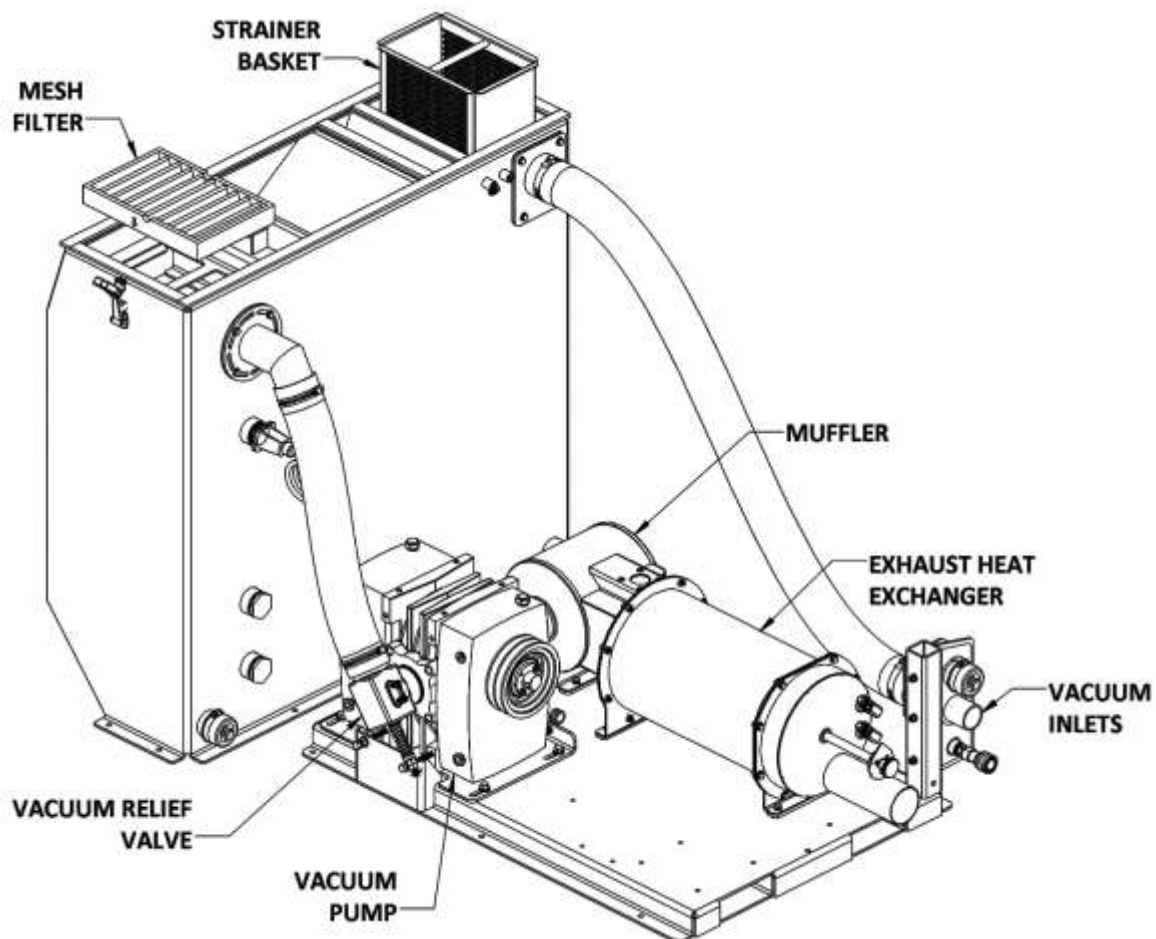

CHEMICAL PUMPING SYSTEM

The chemicals are drawn from the chemical container through a strainer into the flow meter mounted on the control panel. The flow meter indicates the rate of chemical flow.

The chemicals then flow through the stainless steel pulse pump, the chemical is then injected into a three way selector valve located on the front panel. This valve may be used to turn the chemical flow ON, OFF, or to PRIME the chemical pump.

The chemicals then flow through the chemical metering valve to the solution outlet. This valve controls the rate of flow of chemical into the cleaning solution, which is indicated on the flow meter. The chemical setup valve uses vacuum to stimulate the flow to chemical through the system without first connecting tools to the unit.

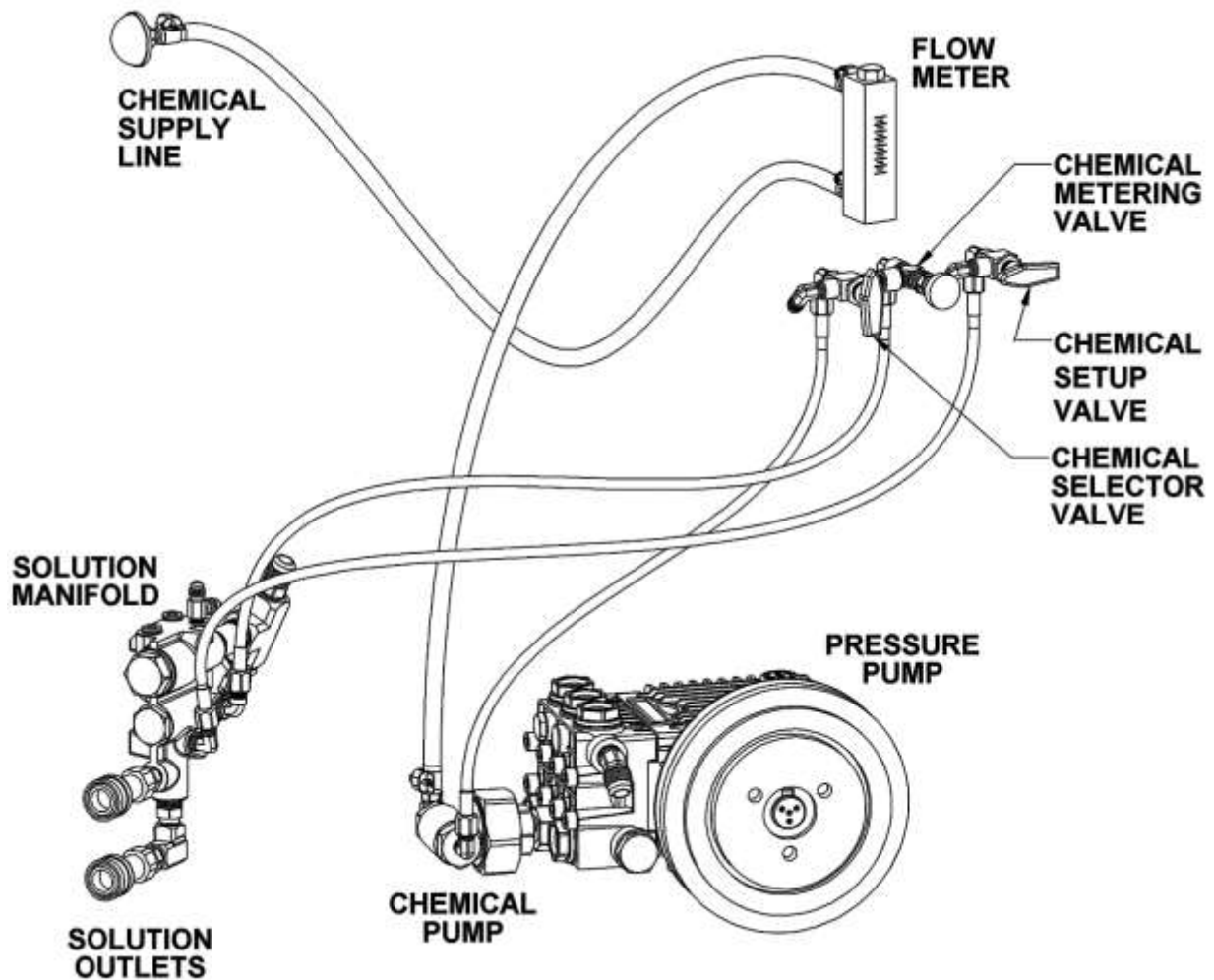

PREPARATION AND OPERATION

This section of the operator's manual explains how to prepare, start, operate, shut down and maintain your Legend Brands Peak 500 mobile cleaning unit. The Peak 500 unit is easy to operate, however only trained operators should proceed.



WARNING Operate this unit and equipment only in a well-ventilated area. Exhaust fumes contain carbon monoxide, which is an odorless and deadly poison that can cause severe injury or death. DO NOT run this unit in an enclosed area. DO NOT operate this unit where the exhaust may enter a building doorway, window, vent or any other opening.

PREPARATION

ENSURE THERE IS ADEQUATE FUEL

Check the fuel tank to ensure there is adequate fuel to complete the job and transport the vehicle. This unit consumes approximately 1.5 US gallons of fuel per hour, depending on the speed setting.

REMOVE TOOLS FROM THE VEHICLE

Remove any tools, accessories or hoses from the vehicle that you will require.

WATER SUPPLY CONNECTION

NOTE: Prior to connecting your water inlet hose to any supply faucet, flush out the faucet until the water is free of any debris. Also, flush out any debris from your water inlet hose.

1. Connect the hose to the water supply faucet and flush out any debris from the faucet and hose.
2. Connect the hose to the water inlet fitting on the front of the unit.
3. Turn the water supply faucet on.

NOTE: Never use a waste pump outlet hose as a water inlet hose. Use only clean hoses for water supply.

CHECK YOUR DRAIN VALVES

Make sure the waste tank and pre-filter box drains are closed.

CONNECT HIGH PRESSURE SOLUTION HOSES

Before starting the unit, connect the high pressure solution hose(s) to the solution outlet connection(s) at the front of the unit. Connect the cleaning tool(s) to the opposite end of the pressure hose(s).

SECTION THREE: USING YOUR CLEANING SYSTEM

CHECK YOUR CHEMICAL LEVELS

Check your chemical container to make sure you have enough chemical mixed to finish the job.

CHECK FILTERS

Inspect the vacuum inlet filter and strainer basket in the waste tank. See the Shut Down and Daily Maintenance section below for more information.



CAUTION

NEVER operate the unit with the waste tank air filter removed, damaged or not properly installed.

INSTRUMENT PANEL CONTROLS AND GAUGES

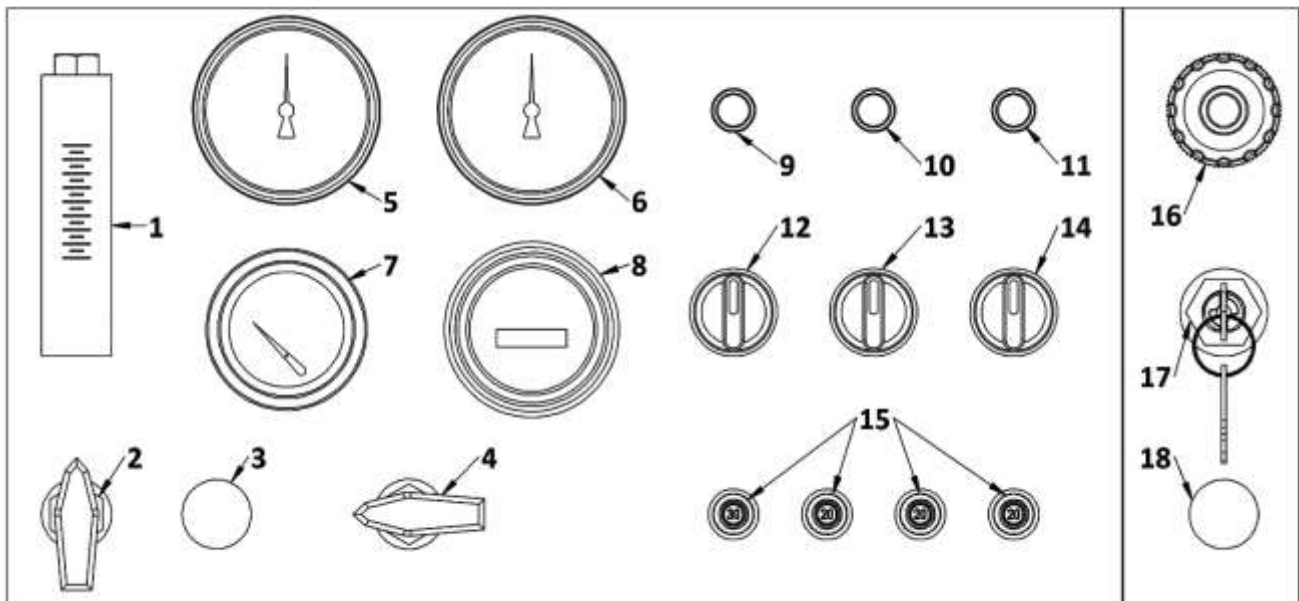

1. CHEMICAL FLOW METER

Visual display of chemical flow through the system.

2. CHEMICAL SELECTION VALVE

The chemical selection valve allows you to start, stop or prime the chemical flow.

3. CHEMICAL METERING VALVE

The chemical metering valve allows you to control the amount of chemical flow being injected into the cleaning solution.

4. CHEMICAL FLOW SETUP VALVE

This valve allows the chemical system to be primed without connecting tools to the unit.

5. WATER PRESSURE GAUGE

This gauge registers the amount of pressure in the water system.

SECTION THREE: USING YOUR CLEANING SYSTEM

6. VACUUM PRESSURE GAUGE

This gauge indicates, in inches of mercury, how much vacuum the system is producing at any given time

7. WATER TEMPERATURE GAUGE

This gauge measures the temperature of the water at the solution manifold.

8. HOUR METER

The hour meter records the operating time of the unit. This is used to calculate maintenance intervals.

9. HIGH TEMPERATURE SHUTDOWN INDICATOR LIGHT

This light is activated by the engine when an overheating condition causes a shut-down. When this occurs, troubleshooting is required.

10. CHECK ENGINE INDICATOR LIGHT

This light is activated by the engine when a problem is detected by the ECU. When this occurs, troubleshooting is required.

11. WASTE TANK FULL INDICATOR LIGHT

This indicator light is activated when the waste tank has reached full capacity. The unit will shut down to protect the components from damage. The waste tank must be emptied before the unit can be brought back in service.

12. PRESSURE PUMP SWITCH

The pressure pump switch turns the pressure pump ON or OFF.

13. AUXILIARY SWITCH

The auxiliary switch is used to turn an auxiliary item ON or OFF, if an optional accessory item, such as a motorized hose reel, has been installed.

14. PUMP OUT SWITCH

The pump out switch is used to turn a waste pump ON or OFF, if an optional automatic waste pump has been installed.

15. CIRCUIT BREAKERS

Circuit breakers protect system components and wiring from electrical spikes or overloading in the system.

16. THROTTLE CONTROL

Turn counter-clockwise to open the throttle (faster speed), clockwise to close the throttle (slower speed). For emergency slow-down, depress the center button and push the throttle control in.

17. IGNITION SWITCH

The engine ignition switch provides ignition to start the engine when the key is inserted and turned.

18. MANUAL BYPASS VALVE

This valve allows the operator to quickly reduce water temperature by bypassing hot water to the waste tank. Turning the valve counterclockwise opens the valve for cooling. Turning clockwise closes the valve.

NOTE: For a greater explanation of gauges, see the section “Gauge Readings and Settings” below.

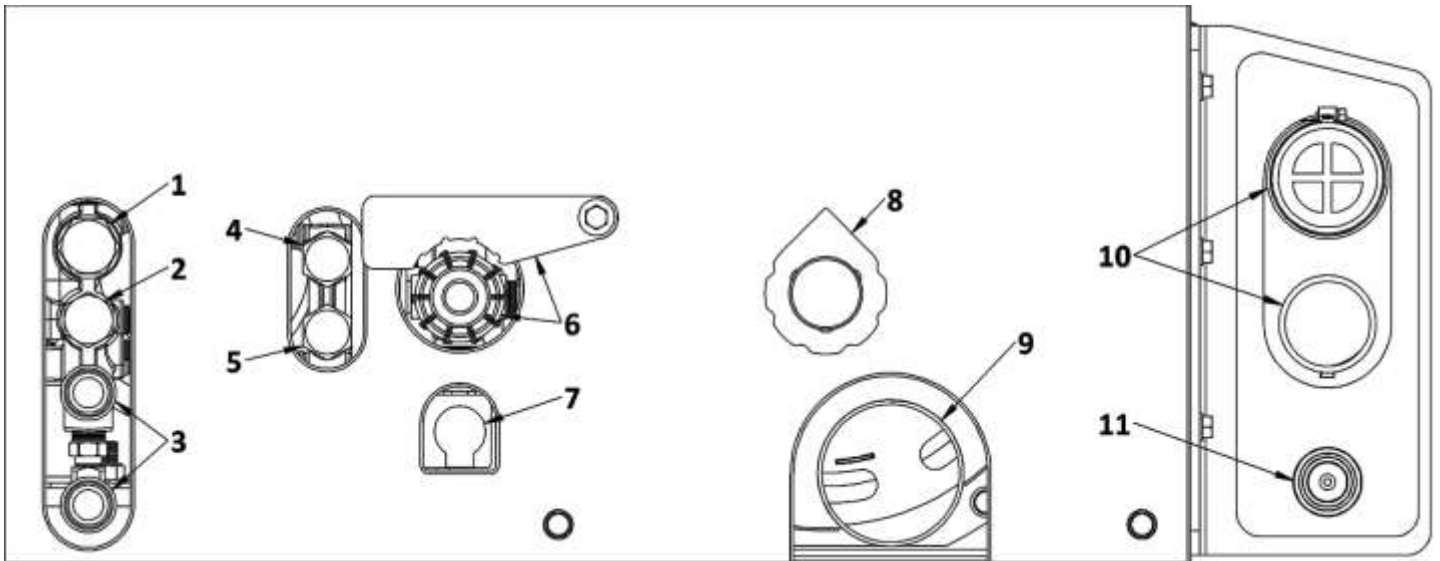
LOWER FRONT PANEL**1. CHEMICAL CHECK VALVE**

The chemical check valve allows the chemical injection into the water stream to form the cleaning solution. This is accessible on the front panel for maintenance and service.

2. SOLUTION SCREEN

The solution outlet filter catches debris in the solution stream before it exits the unit for the cleaning tool.

3. SOLUTION OUTLETS

The pressure outlet is where you connect your solution hose. The Peak 500 has 2 outlets for 2 separate solution hoses.

4. ORIFICE SCREEN

The orifice filter catches debris before it enters the temperature control orifice.

5. TEMPERATURE BALANCE ORIFICE

The orifice in this manifold helps to balance and stabilize the solution temperature within the system.

6. OUTLET PRESSURE REGULATOR

The pressure regulator sets the pressure of the solution system. This spring loaded valve can be adjusted up or down. The pressure is increased by turning the valve clockwise, or reduced by turning the valve counterclockwise. This valve must be maintained in accordance with the maintenance table in this manual. The latch over the valve prevents creeping due to vibration while the unit is running.

SECTION THREE: USING YOUR CLEANING SYSTEM

7. VACUUM LUBRICATION CUP

The vacuum relief valve lubrication cup is used to deliver lubrication to the vacuum pump. This prevents rust from building up inside the pump. See the shut-down and daily maintenance sections for more information.

8. TEMPERATURE CONTROL DIAL

The temperature control dial is locked into place with the locking knob. Turn the locking knob counterclockwise to release the dial to be freely adjusted.

Turning the dial counterclockwise towards the “LOW” setting opens the exhaust damper, reducing heat conduction in the coil. Turning the knob clockwise towards the “HIGH” setting closes the damper, increasing heat generation.

9. EXHAUST OUTLET

Engine and blower exhaust from the unit. Exhaust fumes contain carbon monoxide which is an odorless and deadly poison that can cause severe injury or fatality. DO NOT run this unit in an enclosed area. DO NOT operate this unit where the exhaust may enter any building doorway, window, vent or opening of any type.

10. VACUUM INLET HOSE PORTS

The vacuum inlets are where you connect your vacuum hoses. The Peak 500 has two 2-inch ports. Always cap an unused port to maintain proper vacuum levels.

11. WATER INLET

The water supply inlet is where you connect your fresh water supply hose.

STARTING THE UNIT

NOTE: Read and comply with the preparation section of this manual entirely before starting the unit.

1. Set throttle and turn ignition key to start.
2. Set throttle to desired speed.
3. Turn the pressure pump switch to the ON position.

NOTE: If the unit does not build water pressure after 5 seconds, check for adequate water supply. See “Loss of Water Pump Pressure in the Troubleshooting section of this manual.

VACUUM HOSE

Connect the vacuum hose(s) to the vacuum inlet connection at the front of the unit. Connect the opposite end of the vacuum hose(s) the cleaning tool(s). Let the unit run for a few minutes with the vacuum inlets partially blocked off to warm up the cleaning solution.

Legend Brands recommends that the total floor tool size does not exceed #6. Using larger jet sizes on your Peak 500 unit may reduce cleaning temperatures.

PRIMING THE CHEMICAL PUMP

Legend Brands recommends that the chemical pump be primed whenever the water pump is on. This eliminates possible pressure fluctuations and water pump pulsations related with running the chemical pump dry.

The chemical prime tube and the chemical inlet tube should be inserted into the chemical container before starting the unit. When inserting the chemical tube into the chemical container, ensure that it stays submerged in chemical, as the chemical pump will not function if air is allowed to enter the inlet line.

With the engine running in idle and pressure pump switch in the ON position:

1. Turn the 3-way chemical selector valve located on the control panel to the PRIME position. Allow chemical to circulate. After all air bubbles have been removed from the chemical tube, turn the valve to the ON position.
2. Turn the chemical flow valve to the SETUP position. Use the chemical metering valve to set the desired flow rate. To test the flow rate, trigger the cleaning tool while adjusting the flow. Once set, turn the chemical flow valve to the CHEMICAL position.
3. When the chemical flows with no air bubbles, priming has been achieved. Turn the chemical selector valve from PRIME to METER. With the cleaning tool open, check the flow meter and adjust the chemical metering valve until the desired rate of chemical flow is achieved.

AUTOMATIC WASTE PUMP

1. If your unit is equipped with an optional automatic waste pump, connect one end of the 5/8 in. or larger garden hose to the pump-out connection and the other end to an acceptable waste disposal.
2. Turn the pump-out switch located on the front console control panel to the ON position. The waste pump will now operate automatically throughout the cleaning period.

DO NOT use an outlet hose that is smaller than 5/8 in. I.D.

NEVER use a waste pump hose as a water inlet hose.



NEVER dispose of waste water in a storm drain, water way or on ground areas. Always dispose of waste in accordance with Local, State and Federal laws.

OPERATION

After you have completed the previous steps, proceed with the cleaning or restoration operation. Place the throttle control cable to a minimum of 50% of throttle control maximum for cleaning or restoration. A float shut-off switch is located inside of the waste tank. It will automatically shut down the unit if the tank reaches its full capacity. If this occurs, empty the waste tank before continuing. When doing flood extraction, the water pump should be in the OFF position.

CLEANING

While cleaning, observe the following guidelines:

- Before cleaning, ensure that the wand nozzles are functioning properly.

Hold the wand approximately one foot above the surface to be cleaned and open the wand valve. A full even spray should emit from the cleaning nozzles. If the nozzles are not showing a full even spray pattern, adjust, clean, or replace the nozzles, if required.

- Usually, chemical solution is applied during the push stroke of the wand during cleaning, and extraction is done on the pull stroke. For heavily soiled carpets, the wand may be used in a scrubbing action, with chemical solution applied in both push and pull strokes, provided that the final stroke is a pull stroke with no chemical injection.

SECTION THREE: USING YOUR CLEANING SYSTEM

UPHOLSTERY CLEANING

Run unit at a low speed. Upholstery tools have a lower flow rate and smaller orifices. Set the temperature control dial to the LOW setting. To maintain proper cleaning temperatures, make certain that the unit has been fully heated up prior to cleaning.

STAIR TOOL CLEANING

Run unit on low speed. Set the temperature control dial to the desired temperature range – MED for single wand operation or HIGH for dual wand operation.

FLOOD RESTORATION/EXTRACTION

Set the throttle control on the front control panel to a minimum of 50% of throttle control maximum. Make certain that the water pump switch is in the OFF position. Proceed into the extraction process.

DUAL WAND OPERATION

Dual wand operation will alter vacuum and solution rates. The solution temperature and chemical flow rates may be set slightly higher for dual wand operation.

Always use the LOWEST flow rate that properly cleans the affected areas. Excessive chemicals can cause damage to the items being cleaned.

GAUGE READINGS AND SETTINGS

VACUUM PRESSURE GAUGE

With the unit running, the vacuum gauge should read near zero with vacuum hoses disconnected from the vacuum inlets. If the gauge shows a reading, check the filter in the waste tank and the strainer baskets in both the waste tank and pre-filter box for debris. With vacuum ports sealed, and machine running at high speed, the vacuum gauge should read 11 to 13 inches of mercury (in. Hg). This is preset by the factory for the maximum safe operation. Depending on elevation, this may need to be reset at time of installation.



DO NOT exceed 13 in. Hg vacuum pressure. This can cause damage to the vacuum pump.

TEMPERATURE GAUGE

The LOW temperature setting is for upholstery and delicate cleaning. Set the temperature control dial to MED for single wand operation. The HIGH temperature setting is for dual wand operation or the use of a powered cleaning tool, such as the Legend Brands HOSS. If a lower temperature is desired, open the manual bypass valve on the control panel until the desired temperature is obtained. The highest temperatures will be achieved with the valve closed.

SECTION THREE: USING YOUR CLEANING SYSTEM

WATER PRESSURE GAUGE

Water pressure is set by adjusting the pressure regulator valve on the lower front panel for the desired water pressure. Normal settings are as follows:

- 200 PSI for upholstery cleaning
- 450 PSI for carpet cleaning
- UP TO 1500 PSI maximum

CHEMICAL FLOW METER

The flow meter reads the flow rate from the chemical jug while the chemical is being drawn. The chemical adjustment should normally be set at 1 or 2 GPH for a normal job and at 2 or 3 GPH for an extremely dirty job.

NOTE: The setting is also dependent on the type of chemical used and the concentration ratio of chemical to water.

Always use the LOWEST flow rate that properly cleans the affected areas. Excessive chemicals can cause damage to the items being cleaned.

SHUT DOWN AND DAILY MAINTENANCE

1. Flush out the chemical system with fresh water to remove any chemical residue.
2. Remove as much moisture from the vacuum hoses as possible to prevent spillage of wastewater in your vehicle when returning hoses. Disconnect the vacuum hose from the front of the unit.
3. Adjust the throttle cable to the idle position.
4. Switch the temperature control dial to the lowest setting.
5. Allow the unit to run for at least 5 minutes with the manual bypass valve open. This will also help to remove any excess moisture from the vacuum pump and cool the unit down.

NOTE: If shutting down for the day: Plug the vacuum inlet on the front of the unit and set the throttle to high. Spray a quality silicone or Teflon/PTFE based lubricant into the lubrication cup for 5 seconds. Let machine run 2 minutes to disperse evenly into the blower.

6. Unplug the vacuum inlet and remove load. Next, return the throttle control cable to idle position, and let idle for 3 to 5 minutes.
7. Turn the ignition switch to the OFF position.
8. Turn the water supply faucet off. Loosen the water supply hose at the water supply to bleed off any pressure. Unhook the water supply hose and return it to the vehicle.
9. Activate the valves on all cleaning tools. This will relieve any remaining pressure. Disconnect the cleaning tools and solution hoses and return them to the vehicle.
10. Drain the waste tank, disposing of wastewater in a suitable and proper location.
11. Remove the strainer basket from the waste tank. Clean out any debris and re-install. Micro-ban QGC cleaner is the best product for cleaning and sanitizing the waste tanks as well as other parts of the system.
12. Inspect the vacuum inlet filter inside the waste tank daily. Remove and clean the filter if there is any lint or debris present.
13. At the end of the work day, rinse out the waste tank with fresh water. Microban QGC cleaner as the best product for cleaning and sanitizing the waste tanks as well as other parts of the system.
14. Clean the vehicle interior, unit, tools, hoses etc., as needed. Inspect ALL equipment and accessories for any damage, leaks, wear, etc.

FREEZE PROTECTION / DESCALING

If the unit is exposed to freezing weather conditions, the water inside of the unit may freeze, resulting in **SERIOUS DAMAGE** to the unit. The following is recommended to prevent this from occurring during the cold weather season:

1. Always park the unit in a heated building when not in use.
2. While out in operation, avoid long periods of shut down as the unit generates heat while running. Keep the unit running just prior to leaving for the next job.
3. If a heated building is not available, winterize the unit with anti-freeze.
It is not possible to winterize units that have auxiliary water tanks. If the unit has an auxiliary water tank(s), it must be stored in a heated building.

Hard water deposits will damage the plumbing and heat exchange systems on this unit if not maintained. Legend Brands recommends using a high quality water softener with a minimum flow capacity of 5 GPM in areas where hard water exceeds 3.5 grains. Descaling the unit every three to six months will help prevent calcium deposits or scale build-up in your system. The process for descaling your unit is almost identical to winterizing and are integrated below.

WINTERIZING AND DESCALING YOUR UNIT

1. Disconnect your water supply. If you have an on-board water supply, fully drain it when your unit is down for long periods.
2. Run the unit on low to extract as much water as possible. This can be done through the bypass valve or an open-ended hose connected to the solution outlet. Turn the unit off.
3. Add one gallon of a minimum dilution of 50/50 or 100% glycol based anti-freeze or descaler (follow directions on the bottle of descaling agent of your choice for exact amounts) directly to the water box.
4. Turn the pressure regulator all the way down. Start the unit in idle, turn the pressure pump switch to the ON position and run coolant/descaler through the system. Allow the unit to run for about 3 minutes to fully circulate the coolant/descaler.
5. (Skip this step if descaling) Prime the chemical injection system with a minimum dilution of 50/50 or 100% glycol based antifreeze. Insert the chemical inlet and prime tube into the anti-freeze container. Turn the chemical valve to PRIME until anti-freeze comes out of the prime hose. Turn the chemical valve to the ON (chemical) position. Ensure that the flow meter indicates flow while the attached tools solution valves are opened. Ensure that all anti-freeze that comes out of the chemical hose goes into an approved container.
6. (Skip if descaling) After 25 seconds, turn the chemical valve to the OFF position.
7. If descaling, run an alkaline through the system. Open the manual bypass valve to recover the rinse cycle.
8. Turn the pressure pump switch to the OFF position and turn the ignition switch to the OFF position to turn off your unit.

WINTERIZING THE HOSES AND TOOLS WITH ANTIFREEZE

1. To winterize your hoses and tools, connect all hoses to the solution outlet. Connect a tool to the hoses. Make sure that the tool will drain into an approved container.
2. Make sure the pressure regulator is turned all the way down. Start the unit in idle and turn the water pump on. Open the tool valve until anti-freeze begins to flow from the tool. Repeat this procedure with all hoses and tools as necessary. Disconnect and store the hoses and tools once they have been filled with anti-freeze.

REMOVING ANTI-FREEZE FROM THE UNIT

1. Connect the solution hoses to the unit, with a tool attached to the opposite end. Start the unit. Turn the water pump on. Open the tool valve and ensure that the anti-freeze goes into an approved container. Allow the anti-freeze to flow into the container until all anti-freeze has been drained.
2. Fill the water box with fresh water and repeat step 1.
3. Connect the water inlet hose to the unit and turn the water supply on. Connect all tools and solution hoses that were winterized to the solution outlet connection.
4. Open all tool valves and drain the anti-freeze into an approved container until the water runs clear and all of the anti-freeze is purged from the hoses and tools.
5. Insert the chemical prime hose into the approved container. Submerge the chemical hose into fresh water. Turn the chemical valve to the PRIME position until the water runs clear through the prime hose. Remove the prime hose from the container.
6. Turn the chemical valve to the ON (chemical) position and open attached tools solution valves. This will allow water to flow to the other side of the system.
7. After all of the anti-freeze has been removed, the unit is ready to operate.

The anti-freeze in your approved storage container will eventually become diluted with water. When the anti-freeze level drops below 40% of the total mixture, properly dispose of it and start over with fresh anti-freeze.

WARNING!

DO NOT drain used anti-freeze on the ground or into storm drains.

Dispose of anti-freeze only in an approved location. Observe Local, State and Federal laws when disposing of anti-freeze.

SECTION FOUR: SERVICE AND MAINTENANCE

PEAK 500 MAINTENANCE CHART

DAILY MAINTENANCE

Engine	Check engine oil level. Fill to proper level.
Engine	Check and clean radiator screen.
Vacuum Pump	Check vacuum pump oil level. Fill to proper level. Do not overfill. (1)
Vacuum Pump	Spray a silicone or Teflon/PTFE based lubricant into the lubrication cup for 5 seconds.
Pressure Pump	Check water pump oil level. Fill to proper level. (2)
Vacuum Inlet Filters	Inspect filters in the waste tank, clean and or replace if required. (1)
Strainer Basket	Empty and clean stainless steel basket in the waste tank.
Vacuum Hoses	Rinse with fresh water.
Waste Pump-Out	(Optional equipment) Inspect and remove any debris or sediment. (1)

WEEKLY MAINTENANCE

Float Switch(es)	Clean and inspect float switch(es) in the waste tank.
Visual Inspection	Check for leaks around the unit, check wires and hoses for wear.

MONTHLY MAINTENANCE

Engine	Check air filter for damaged, dirty or loose parts.
Engine	Inspect drive belts for wear. Replace as needed.
Battery	Check fluid level and battery terminals. (1)
Check Valve Strainer	Clean and remove debris (1, 3)
Check fasteners	Check fastener tightness on all components. Tighten as needed.

YEARLY MAINTENANCE

Check-Valve	Check seat for abnormal wear or debris. Replace as needed.
-------------	--

To maximize the operating life and performance, use only recommended oils, filters and greases.

- (1) Or as often as required.
- (2) Change water pump crankcase oil after **first 50 hours** of operation.
- (3) Inspect after **first week** of operation, and remove any debris present. Inspect again after **2 to 4 weeks**.

PEAK 500 SERVICE INTERVAL CHART**SERVICE INTERVALS – EVERY 50 HOURS**

High Pressure Hoses	Inspect hoses for wear, damage or impending rupture. Replace if damaged.
Engine	Tighten bolts, nuts and screws.
Engine	Inspect and clean air filter foam element. Replace if damaged. (7)

SERVICE INTERVALS – EVERY 100 HOURS

Engine	Change engine oil and filter. (2)
Vacuum Relief Valve	Check and adjust vacuum relief valve up to 13” Hg if needed.
Pressure Regulator	Lubricate o-rings. Use only o-ring lubricant. (Legend Brands P/N 13-003)
Belts	Re-tension all belts. (1)
Battery	Clean battery terminals.
Engine	Check spark plugs. Clean or replace and re-gap as needed.

SERVICE INTERVALS – EVERY 200 HOURS

Engine	Inspect radiator and hoses. (7)
Engine	Check fan belt condition and tension.

SERVICE INTERVALS – EVERY 250 HOURS

Chemical Metering	Inspect packing nut on selector and metering valves. Adjust as needed.
Engine	Inspect and clean air filter paper element. Replace as needed. (7)

SERVICE INTERVALS – EVERY 300 HOURS

Engine	Check and adjust valve clearance.
--------	-----------------------------------

SERVICE INTERVALS – EVERY 500 HOURS

Pressure Pump	Change crankcase oil. (3)
Engine	Replace in-line fuel filter. (6) (7)
Engine	Change coolant.
Pulleys and Hubs	Check pulleys and hubs for proper torque. (4)
Chemical Pump	Change diaphragm and check valves. Inspect disc.

SERVICE INTERVALS – EVERY 1000 HOURS

Vacuum Pump	Drain, flush and replace oil. (5)
Engine	Replace spark plugs. Use only OEM spark plugs.
Engine	Replace air filter paper element. (5)

SERVICE INTERVALS – EVERY 2000 HOURS

Belts	Replace all belts.
-------	--------------------

To maximize the operating life and performance, use only recommended oils, filters and greases.

- (1) Re-tension belts after **first 25 hours**, then every **100 hours** of operation after.
- (2) Change engine oil and oil filter after **first 8 hours** of operation and then **every 100 hours**.
- (3) Change water pump crankcase oil after **first 50 hours** of operation, then **every 500 hours**.
- (4) Check pulley and hub set screws after **first 50 hours** of operation, and again at **100 hours** of operation.
- (5) Every **1000 hours** or **yearly**, whichever comes first.
- (6) Every **500 hours** or **yearly**, whichever comes first.
- (7) Increase intervals in dusty conditions.

MAINTENANCE AND SERVICE ADJUSTMENTS

This section of the operator’s manual contains the service and maintenance information for the Peak 500. A planned preventative maintenance program will ensure that your Peak 500 has optimum performance, long operating life, and a minimum amount of down time.



WARNING

DO NOT attempt to service this unit while it is running. High speed parts as well as high temperature components may result in severe injury, severed limbs, or fatality.

NOTE: Refer to the hour meter as a guide for coordinating a maintenance schedule.

ENGINE

- **Check engine oil daily.** Ensure that the proper oil level is maintained. Never overfill.
- Change the oil after the **first 8 hours** of operation. Thereafter, change the oil and filter **every 100 hours** of operation. Use only OEM oil filters. Use of any other type of oil filter will void engine warranty.
- Use high-quality oil of at least API (American Petroleum Institute) service class SG or higher. **Do not use additives.** High quality 20W-50 oil is recommended in extreme hot climates due to ambient temperature increase inside the vehicle during operation. It is never recommended to extend oil change intervals past 200 hours.

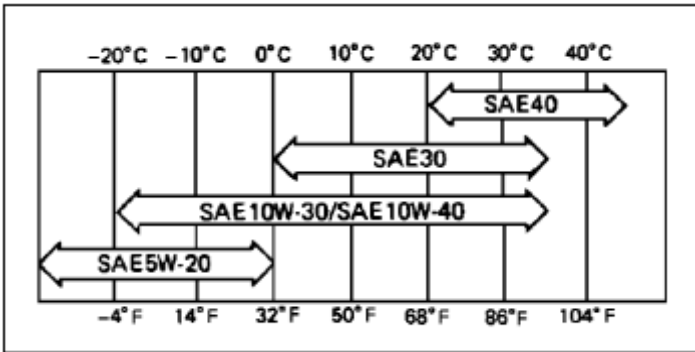

NOTE: Using lower service class oil or extending oil change intervals longer than recommended can cause engine damage.

Engine Oil Capacity	1.8 L / 1.9 US qt when oil filter is not removed
	2.0 L / 2.1 US qt when oil filter is removed
Coolant Capacity	2.7 L / 2.9 US qt

Tightening Torque	
Oil Drain Fitting	25 N·m 2.6 kgf·m 18 ft lb (215 in lb)

- Tighten bolts, nuts and screws **every 50 hours.**
- Check the radiator screen **daily**, clean as needed. Inspect the radiator and hoses for leaks **every 200 hours.**
- Inspect and clean the air filter foam element **every 50 hours.** Replace the element if damaged.
- Inspect and clean the air filter paper element **every 250 hours** and replace it **every 1000 hours or yearly**, whichever comes first.
- Inspect, clean and re-gap the spark plugs every **100 hours** of operation. Replace the spark plugs **every 1000 hours** or as needed. Use only OEM specified spark plugs.
- Check and adjust valve clearances **every 300 hours.**
- Change coolant **every 500 hours.**
- Replace the inline fuel filter **every 500 hours or yearly**, whichever comes first.
- Adjust the engine speed as needed.

DO NOT attempt to adjust without a tachometer and NEVER adjust the engine above 3000 RPM.

THROTTLE	LOAD	RPM*
Idle	None	1450 RPM
Full	13" Hg. vacuum 500 PSI pressure	2850 RPM
Full	None	2950 RPM

*±50 RPM tolerance

VACUUM PUMP

NOTE: Refer to the provided vacuum pump Operation and Service Manual for specific instructions.

- Check the oil level on the gear side **daily** to ensure the proper level is maintained. Too little oil will damage and ruin the bearings and gears. Too much oil will result in overheating.

Legend Brands requires that you use only AEON PD-XD Synthetic Blower Lubricant in both sides of the vacuum pump for all operating temperatures. AEON PD-XD is formulated specifically for positive displacement blower service to provide maximum blower protection at any temperature. AEON PD-XD (Legend Brands Part # 13-004) is the only oil that Legend Brands puts in the vacuum pump at the factory. Adding petroleum oil to synthetic oil is NOT recommended.

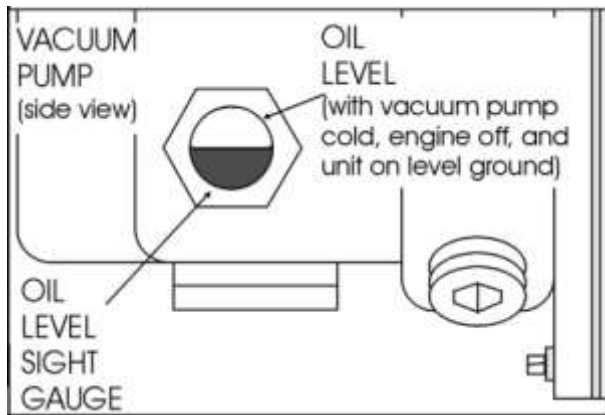

Vacuum Pump Oil Capacity	
Shaft End	1 pint (16 oz)
Gear End	1.5 pints (24 oz)

- A lubrication cup has been provided at the front of the console, to prevent rust from building up inside of the vacuum pump. Run the unit for at least 2 minutes to remove any moisture from the vacuum pump. Then, spray a quality silicone or Teflon/PTFE based lubricant into the lubrication cup for 5 seconds while the unit is running and the vacuum inlet port is sealed. This procedure should be done at the **end of every working day**.
- Drain, flush and replace the oil **every 1000 hours or yearly**, whichever comes first.
- Bearings on the drive (shaft) end of the blower require grease lubrication every 500 hours of operation.

Legend brands recommends using only AEON PD Grease. If you choose not to use AEON PD Grease, select a compatible base grease. The grease should be NLGI Grade 2 EP, contain rust inhibitors and be suitable for blower discharge temperatures up to 350° F (177° C). Completely clean or purge the factory-filled grease from the blower.

CAUTION

DO NOT mix different types of grease as they may not be compatible. Substitutions may cause early bearing failure.

NOTE: When re-greasing, old grease will be forced out of the vents. To prevent damage to the seals, these vents must remain open at all times.

PRESSURE PUMP

NOTE: Refer to the provided Pressure Pump Operation Manual for specific instructions.

- Check the crankcase oil level **daily** to ensure the proper level. If the level has dropped, check for the source of leakage and repair.

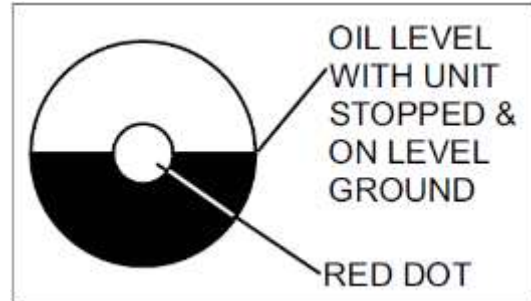
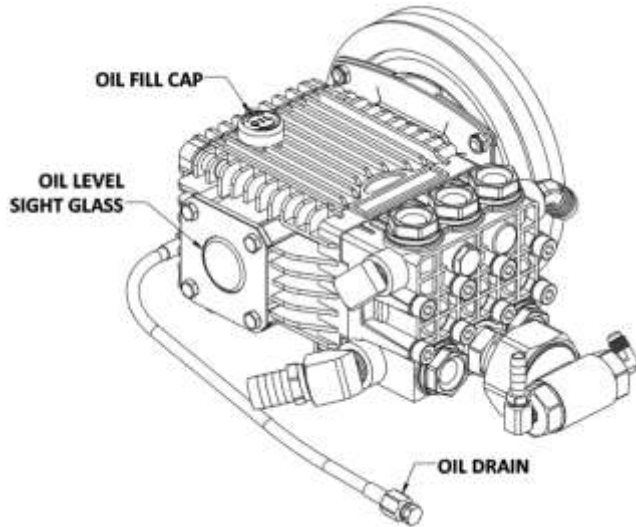

Pressure Pump Oil Capacity	14 oz.
-----------------------------------	--------

- After the **first 50 hours** of operation, change the crankcase oil Industrial Pump Oil, (Part # 13-030). Change the crankcase oil **every 500 hours** thereafter.

DRIVE BELTS, PULLEYS AND HUBS

Check pulley and hub screws after the **first 50 hours** and again at **100 hours** of operation. Re-torque these bolts with a torque wrench. Follow the torque values on the following table. Check pulley set screws and hub screws **every 500 hours** thereafter.

Ensure belts are properly tensioned after checking the torque values. Use Gates EPDM belts for the drive belts and Kawasaki 59011-2056 for the engine cooling fan belt.

Use a clockwise pattern when re-torquing screws and continue until the proper torque is achieved.

Pulley Hub Torque Values		Notes
Engine lower front pulley 5/16" screws	180 in lb / 15 ft lb	Apply blue Loctite
Engine rear drive pulley 1/4" screws	160 in lb / 13 ft lb	Apply blue Loctite
Vacuum pump pulley 1/4" screws	160 in lb / 13 ft lb	Apply blue Loctite
Engine cooling fan pulley M8 bolts	180 in lb / 15 ft lb	

Belt Tensions	Deflection	New	Used
Gates Tri-Power EPDM BX vacuum pump belts	3/16"	8-11 lbs.	5-8 lbs.
Gates Tri-Power EPDM AX pressure pump belt	7/32"	4-6 lbs.	3-4 lbs.
Kawasaki 59011-2056 cooling fan belt	1/8"	6-8 lbs.	5-6 lbs.

VACUUM PUMP BELT REPLACEMENT

Only use Gates EPDM belts

1. Disconnect the negative battery cable.
2. Remove belt guard rear cover and lower side belt guard.
3. Loosen the blower-side hose clamp on the hose between the blower and silencer.
4. Loosen the four blower mounting bolts.
5. Loosen the jam nuts on the blower adjustment bolts, then turn the bolts counterclockwise to allow the blower to be pushed towards the center of the unit to loosen the belts.
6. Remove both belts. Install new belts.
7. After belts have been installed, follow the step above in reverse. Check for proper tension and alignment. Do this using a belt gauge. Set deflection to 3/16" with 8-11 lbs. of tension.
8. Check pulleys for alignment using a straight edge (example: 1/2" key stock). Make sure pulley flange touches on 2 places on each pulley (4 total places).

WATER PUMP DRIVE BELT REPLACEMENT

Use only Gates EPDM belts

1. Disconnect the negative battery cable.
2. Remove the left side hood.
3. Loosen the four nuts that hold the water pump base to the riser plate.
4. Turn the tensioning bolt counterclockwise to push the pump towards the center of the unit to loosen the belt.
5. Remove the belt. Install new belt.
6. After the belt has been installed, follow the above steps in reverse. Check for proper tension and alignment. Do this using a belt gauge. Set deflection to 7/32" with 4-6 lbs. of tension.
7. Check pulleys for alignment using a straight edge. There is a 1/4" gap between the water pump pulley and the lower front engine pulley.

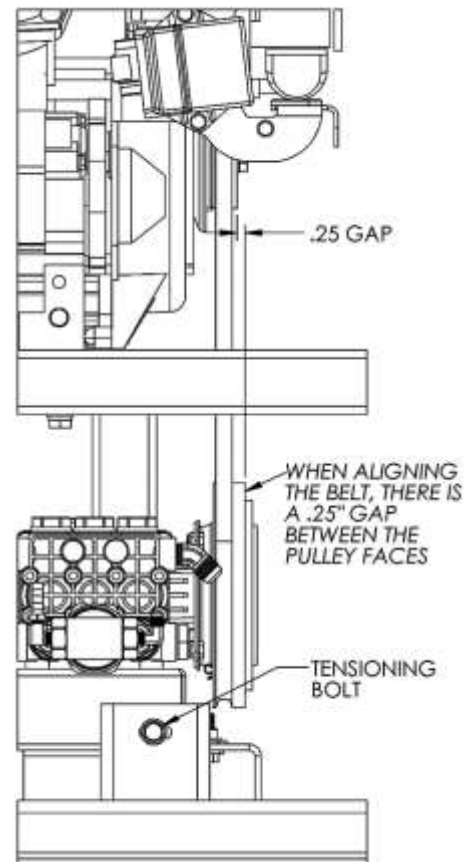

CHEMICAL PUMP

The chemical pump should be rebuilt **every 500 hours**. This involves changing the diaphragm, check valves, and inspecting the disk. **DO NOT** attempt to reuse o-rings after the check valves have been removed. Replace all o-rings when servicing check valves.

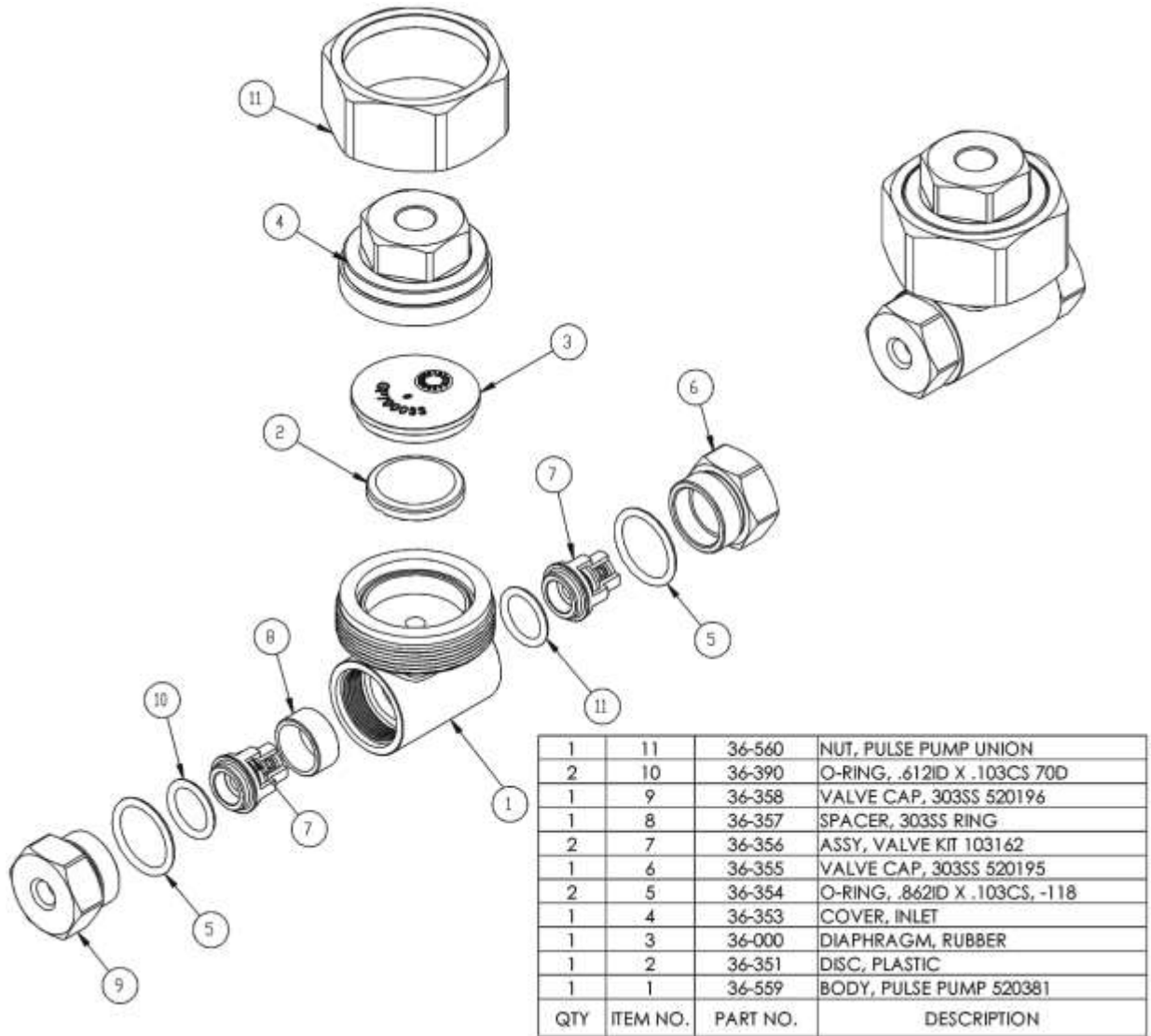

SOLUTION MANIFOLD CHECK VALVE AND STRAINER

Unscrew the screen and inspect the strainer after **the first week** of operation. Remove any debris present. Inspect again **after 2 and 4 weeks**. Thereafter, inspect the strainer and screen at least **monthly**. If a frequent build-up of debris is noticed, inspect and clean more frequently.

Always inspect the check valve and solution manifold strainer whenever performing service on the chemical pump or if flow problems are occurring in the chemical system.

1. Shut down Unit.
2. Remove and clean strainer mesh.
3. Remove the check valve, ensuring that the small o-ring on the seat comes out with it.
4. Next, remove the seat using a 5/16 in. Allen wrench.
5. Check the seat for wear or debris. Clean and replace the seat if necessary.
6. Inspect the poppet and the spring for wear or damage. Clean and replace as necessary.
7. Re-assemble the check valve. Thread the seat by hand until snug. Then tighten with a 5/16 in Allen wrench. **DO NOT** over-tighten.
8. Lubricate the new o-rings with o-ring lubricant (Part # 13-003) and re-install.

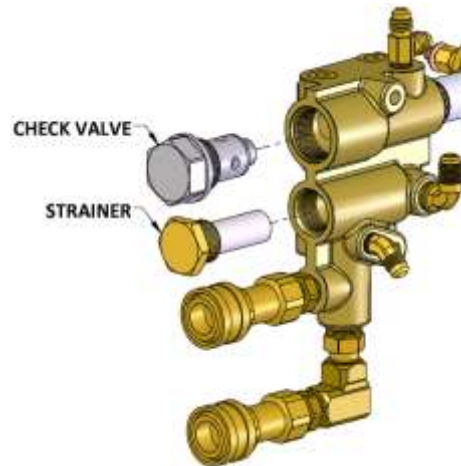

NOTE: New o-rings must be installed **anytime** the check valve is removed.

NOTE: Improper seating of the check valve seat, poppet, damaged spring or o-rings will result in poor performance of the chemical system.



23-063 ASSEMBLY, CHECK VALVE MANIFOLD

Item #	P/N	Qty.	Description
1	27-009	1	CAP, CHECK VALVE ASSY. SS
2	41-007	1	ORING, 7/8 ID X 1-1/16 OD
3	15-007	1	SPRING, CHECK VALVE ASSY.
4	27-010	1	POPPET, CHECK VALVE ASSY
5	27-004	1	INSERT, SEAT-CHK VLV ASSY TM
6	27-011	1	SEAT, CHECK VALVE ASSY.
7	41-008	1	ORING, ½ ID 5/8 OD

PRESSURE REGULATOR

The pressure regulator holds water pressure at a preset point and bypasses the excess water.

To adjust:

With the unit running, with the cleaning tool valve closed, the pressure gauge should read 0. With the tool valve open, adjust the pressure by turning the adjusting knob so that the pressure gauge reads between 0 - 1500 PSI.



WARNING

DO NOT loosen the adjusting body (cap) all the way (counterclockwise) or remove it while the unit is running.

Lubricate the o-rings in the pressure regulator **every 100 hours**.

Use only o-ring lubricant (Part #13-003).

If you do not, the stem may become seized due to inadequate lubrication. If this occurs:

1. Shut down the unit.
2. Relieve all pressure from the water system.
3. Loosen the valve nut and remove the valve stem with long nose pliers.
4. Clean and lubricate stem.
5. Reassemble pressure regulator.
6. Check the port cap o-rings for proper lubrication as well.

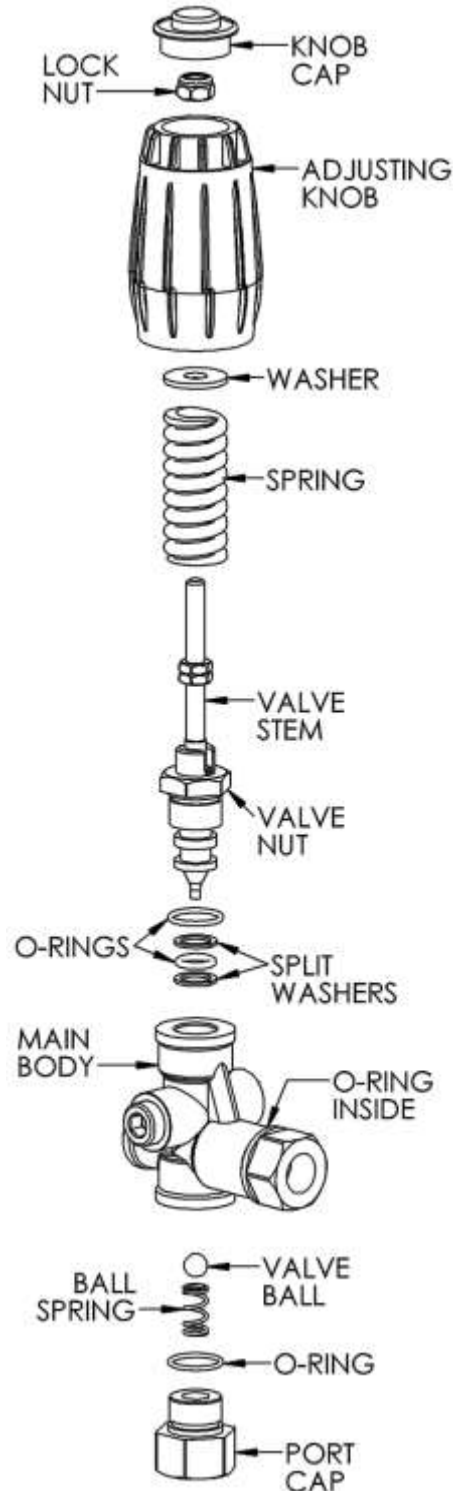

CHEMICAL METERING SYSTEM

Check and inspect the packing nut on the chemical selector and metering valves **every 250 hours**. Keeping the valve packing's properly adjusted will prevent leaks and add to the overall life of the valves.

When turning the knob, there should be some resistance. If not, slightly tighten the packing nut. **DO NOT** over tighten. Keeping the packing properly adjusted will eliminate possible leaks and will add to the overall life of the valves.

23-027, CHEMICAL SELECTOR VALVE

Adjust The Packing Nut
By Turning The Packing Bolt
Clockwise In 1/16"
Increments.

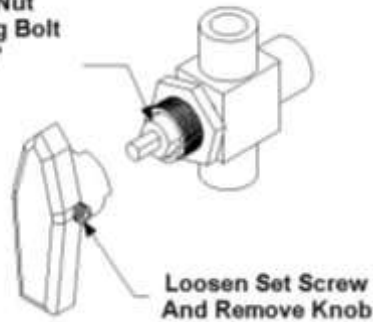

23-028, CHEMICAL METERING VALVE

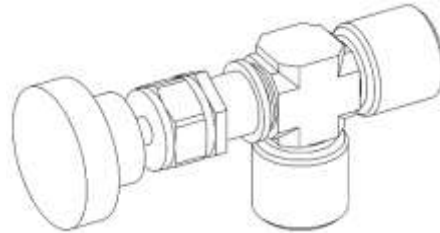

WASTE TANK FILTER AND STRAINER BASKET

The waste tank filter and strainer basket should be removed, inspected and cleaned **daily**. When replacing the filter, ensure that the flow indicating arrow is pointing down.

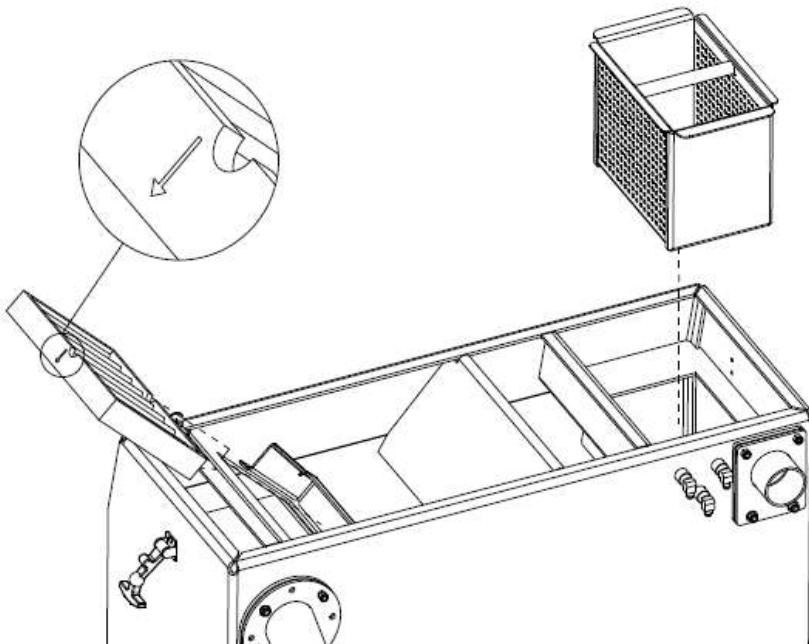

BATTERY

WARNING!

Explosive gases, Dangerous acid!

Batteries contain sulfuric acid. To prevent acid burns, avoid contact with skin, eyes and clothing. Batteries also produce explosive hydrogen gases while charging. To prevent fire or explosion, charge batteries only in a well ventilated area. Keep sparks, open flames, as well as any other sources of ignition away from batteries at all times. Remove all jewelry prior to servicing batteries.

Before disconnecting the negative (-) ground cable, ensure that all switches are in the OFF position. If ON a spark could occur at the ground connection terminal, which could cause an explosion if hydrogen gas or gasoline vapors are present. ALWAYS disconnect the negative (-) terminal first.

- If you do not have a maintenance free sealed battery, check the fluid level in the battery at least once a week. If low, fill to the recommended level ONLY with distilled water. DO NOT overfill the battery. Early failure or poor performance will result due to loss of electrolyte.
- Keep cables, terminals and external surfaces of the battery clean and dry. A buildup of corrosive acid or grime on the external surfaces could cause the battery to self-discharge.
- Battery terminals should be cleaned every 100 hours to prevent corrosion buildup. Wash the cables, terminals and external surfaces with a mild baking soda and water solution. Rinse thoroughly with fresh water. DO NOT allow baking soda to enter the battery cells, as this will destroy the electrolyte, resulting in battery failure.

VACUUM HOSES

To ensure maximum hose life, Legend Brands recommends that you wash out the hoses with fresh water **daily**. Micro-ban QGC cleaner as the best product for cleaning and sanitizing the wands and hoses as well as other parts of the system.

HIGH PRESSURE SOLUTION HOSES

Inspect your high-pressure solution hoses for wear after the **first 100 hours**. Thereafter, inspect **every 50 hours**. If the hoses show any signs of damage or impending rupture, replace the hoses.

WARNING!

NEVER attempt to repair high-pressure solution hoses. Repairing high-pressure solution hoses may result in severe burns and serious injury.

All high-pressure solution hoses must be rated for 3000 PSI at 250 deg. F. Thermoplastic hoses do not meet this requirement and should not be used. Severe burns and injury may result if the hoses do not meet these requirements.

INSTRUMENT PANEL ACCESS

To easily access the rear of the instrument panel for maintenance:

1. Remove the upper and lower front end bezel components by removing the twelve screws around the perimeter (shown in Figure 1), removing the upper section first, then the lower section and carefully set them aside.
2. Remove the left and right side hood panels and carefully set them aside.
3. Using a 3/8" socket and 6-inch extension, loosen the retaining screws (as shown in Figure 2). Do not completely remove these screws.
4. With the screws loose, you can now pivot the top of the instrument panel forward (as shown in Figure 3 below), allowing for maintenance access to the panel. If you need more access, you can remove the middle screw on the left side. Be careful not to overextend the wire harness coming through the upper right as this could damage the unit.
5. Follow these instructions in reverse to close up the unit.

NOTE: Do not over tighten the screws holding on the upper and lower front bezel, doing so may damage these components.

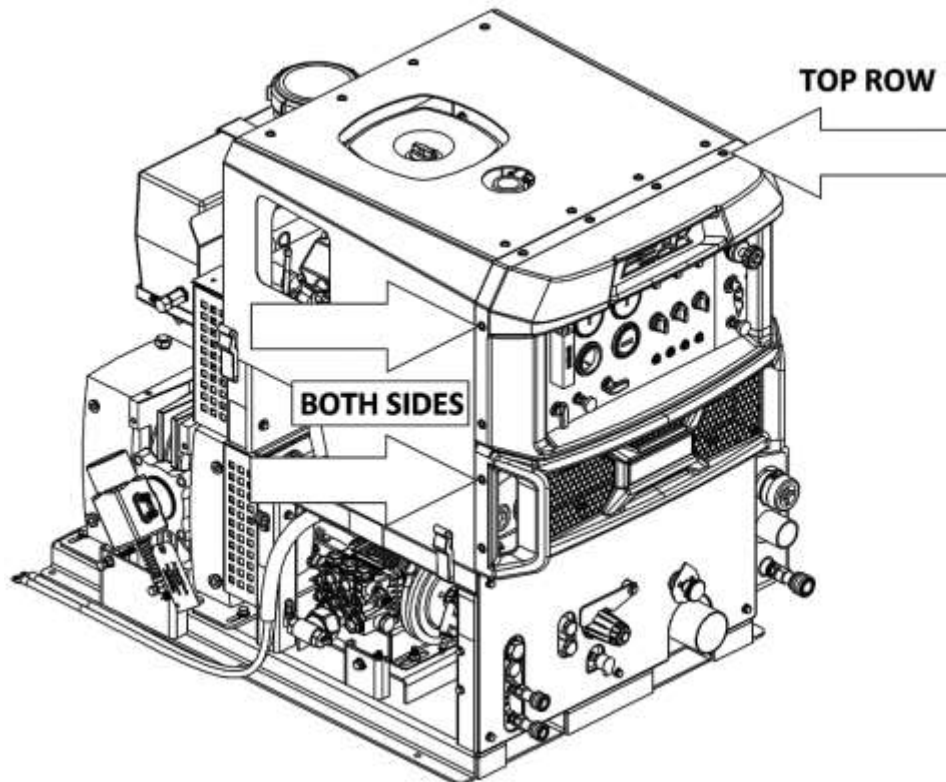

Figure 1 - Top and Side Bezel Screws

INSTRUMENT PANEL ACCESS

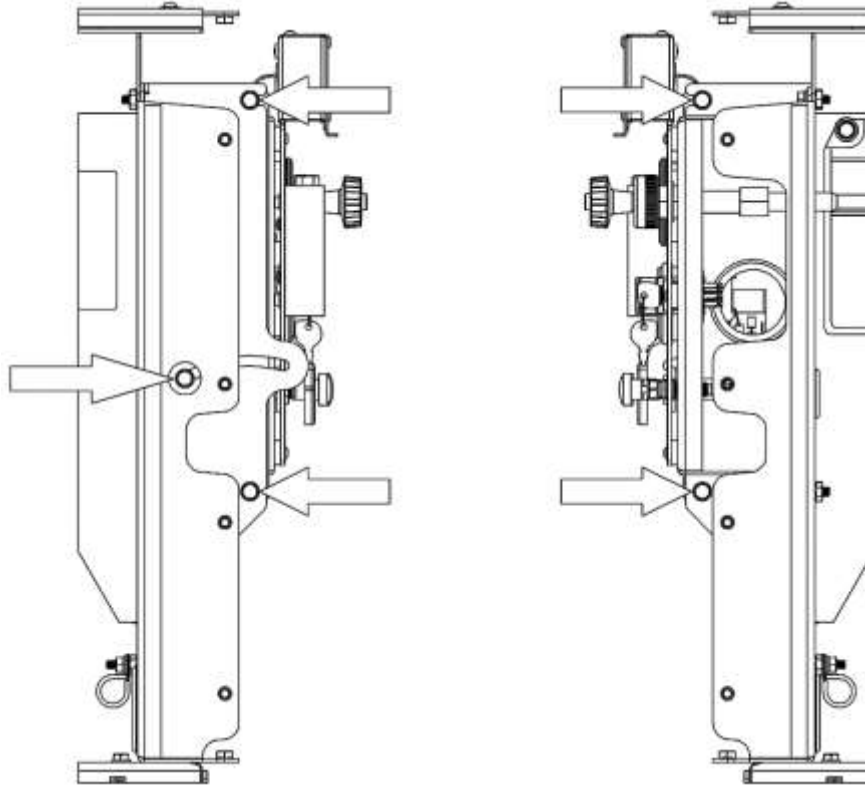

Figure 2 - Right and Left Side Views

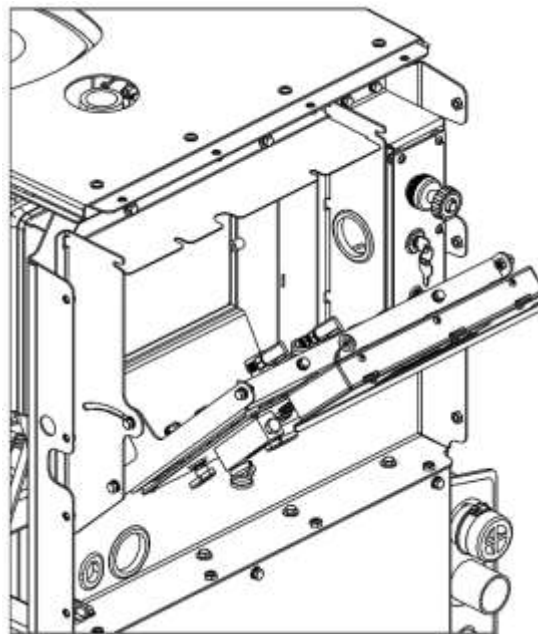
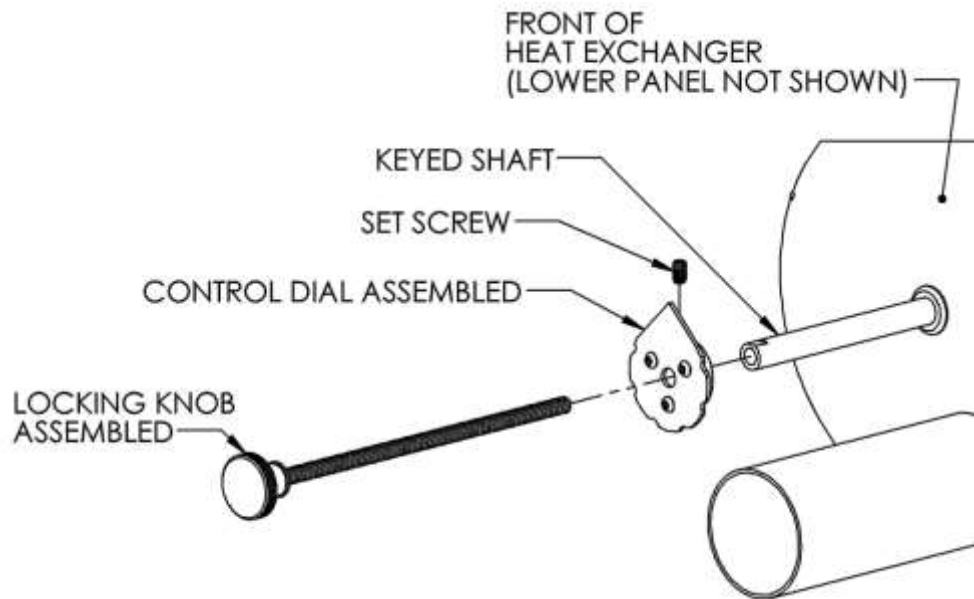

Figure 3 - Instrument Panel Access

REMOVING THE LOWER PANEL

To remove the lower panel, the temperature adjustment dial and locking knob must first be removed:

1. Remove the locking knob by turning it counterclockwise until it finally comes all the way out.
2. Remove the set screw from the control dial collar.
3. Slide the control dial off the keyed shaft.
4. Remove the 1/4" screws bolting down the lower panel and carefully remove the panel.
5. Follow these instructions in reverse to reinstall the temperature control hardware and lower panel.



TROUBLESHOOTING

 **WARNING!**

DO NOT attempt to service this unit while it is running. High-speed parts as well as high temperature components may result in severe injury, severed limbs or fatality.

This section of the operator's manual describes how to look for and repair malfunctions, which may occur.

Accurate troubleshooting is based on a thorough and complete understanding of the WATER, CHEMICAL, VACCUM, HEAT TRANSFER, SAFETY and WIRING systems featured in this unit.

If there are malfunctions occurring on this unit which you do not understand, refer back to the OPERATION section of this manual and review SYSTEM.

 **WARNING!**

Do not alter or modify your Peak 500 in any way. Use only replacement parts authorized by Legend Brands. Modifications or use of unapproved parts could create a hazard and will void your warranty. Contact your authorized Legend Brands dealer for assistance.

ENGINE TROUBLESHOOTING**ENGINE WILL NOT START (STARTER DOES NOT TURN OVER)**

PROBABLE CAUSE	SOLUTION
Main circuit breaker on the control panel has been tripped.	After inspecting the unit to determine the cause of the tripped breaker, press the reset button.
Loose or corroded battery connections.	Clean, tighten or replace the battery terminals.
Dead battery.	Recharge or replace battery
Defective ignition switch.	Test ignition switch for power going into the switch. If there is power going in, but none coming out, replace the switch.
Defective starter motor.	Test the starter motor. Replace if necessary.
Vacuum pump seized.	Refer to the vacuum pump manufacturer service and repair manual.

STARTER TURNS OVER BUT ENGINE WILL NOT START

PROBABLE CAUSE	SOLUTION
Recovery tank is full.	Empty the recovery tank.
Defective fuel pump.	Replace the fuel pump.
Loose or broken wires leading to the recovery tank float switch.	Repair or replace any broken electrical connections.
Defective float switch inside recovery tank.	Check switch for proper operation. Replace if necessary.
Engine is malfunctioning.	Refer to the engine owner's manual.

ENGINE STOPS RUNNING DURING NORMAL OPERATION

PROBABLE CAUSE	SOLUTION
Engine is out of gasoline.	Check the fuel tank.
Recovery tank is full.	Empty recovery tank.
Main circuit breaker on the control panel has been tripped.	After inspecting the unit to determine the cause of the tripped breaker, press the reset button.
Defective fuel pump.	Replace fuel pump.
Defective float switch inside recovery tank.	Check switch for proper operation. Replace if necessary.
No ignition in the engine or the engine is malfunctioning.	Refer to the engine owner's manual.

VACUUM PUMP TROUBLESHOOTING**LOSS OF VACUUM** (while cleaning, engine RPM is normal but vacuum is lower than expected)

PROBABLE CAUSE	SOLUTION
Vacuum gauge is giving an improper reading.	Examine the tubing between the vacuum relief valve and the vacuum gauge and remove any blockage.
Vacuum hose(s) is damaged, causing a suction leak.	Inspect hose(s), repair or replace.
Waste tank gaskets not sealing properly, not positioned properly.	Inspect the gasket. Repair seal or replace Re-position lid(s).
Plugged vacuum hose or vacuum plumbing between vacuum inlet and strainer basket.	Unplug vacuum hose or inlet plumbing.
Waste tank filter or strainer basket is plugged.	Clean or replace filter. Clean strainer basket.
Loose vacuum pump drive belts.	Tighten the drive belts.
Waste tank drain valve is damaged or left open, causing a vacuum leak.	Drain the waste tank. Close drain valve, if open. Replace valve if defective.
Vacuum relief valve requires adjustment or has a vacuum leak due to damaged diaphragm.	Re-adjust the vacuum relief valve. If the vacuum does not increase, remove and inspect the relief valve diaphragm. If damaged, replace.
Vacuum exhaust heat exchanger plugged.	Remove and clean.
Vacuum pump is worn out.	Replace the vacuum pump.

EXCESSIVE VACUUM (while cleaning, engine RPM is normal but vacuum is higher than expected)

PROBABLE CAUSE	SOLUTION
Vacuum relief valve requires adjustment.	Readjust vacuum relief valve to 13" Hg.
Improper throttle adjustment.	Adjust throttle to set desired vacuum pressure.

PRESSURE PUMP TROUBLESHOOTING**LOSS OF SOLUTION PRESSURE (CLEANING TOOL OPEN, SOLUTION GAUGE READS LOW)**

PROBABLE CAUSE	SOLUTION
Water supply is turned off or the float valve is stuck.	Turn the water supply on or up. Check for kinks in the water supply hose. Examine the float or replace.
Solution pump inlet supply line is plugged or drawing air.	Examine filter screen inside the water box. Remove accumulated debris and replace if required. Check for suction leaks and loose clamps or fittings. Tighten any loose fittings or clamps. Replace any ruptured hose(s).
Improper engine speed.	Using a tachometer, check the engine speed. Full throttle engine speed is 2950 ±50 RPM. Idle engine speed is 1450 ±50 RPM.
Pressure regulator o-rings are dry and/or worn. See instructions on regulator.	Check o-rings. Lubricate and/or replace as needed, using o-ring lubricant.
Pressure regulator is dirty, stuck open, or improperly adjusted. See instructions on regulator.	Clean or repair regulator. Adjust to working pressure. Lubricate o-rings, using o-ring lubricant.
Low pump volume. (Measure the amount of water being returned to the water box from the pressure regulator. It should fill a gallon container about every 17.6 seconds).	Examine the check valves, plunger cups, and cylinder head on the water pump. Repair, whenever required (refer to the water pump service manual).
Defective water pressure gauge.	Replace gauge.
Orifice (spray nozzle) in the cleaning tool is worn, defective or wrong size.	Replace Nozzle or change nozzle size.
Debris clogging water lines or water inlet disconnect.	Clean or replace as needed.
Belts loose or broken.	Re-tension or replace as needed.
Loss of pump prime.	Manually prime water pump.
Temperature Balance Orifice missing.	Replace Orifice.

LOSS OF SOLUTION VOLUME AT TOOL (PRESSURE GAUGE READS NORMAL)

PROBABLE CAUSE	SOLUTION
Plugged orifice and/or screen in the cleaning tool.	Unplug or replace orifice and/or screen.
Internal block between the inlet pressure regulator and the solution outlet manifold, or the solution screen is clogged.	Inspect all lines, remove accumulated debris which is blocking flow. Replace any defective hoses. Remove, inspect, and clean the solution screen. De-scale unit and install a water softener, if necessary.
Outlet check valve is plugged.	Examine the check valve, remove any debris.
Defective quick-connect on one or more of the high pressure hoses.	Replace defective quick-connects(s) on high pressure hoses(s).
Cleaning tool valve is malfunctioning.	Repair or replace valve.
Hose inner lining is constricted.	Remove restriction or replace hose.
Air leak in chemical supply line, priming valve or metering valve.	Check for air leaks. Replace faulty parts.

SECTION FOUR – SERVICE AND MAINTENANCE

PRESSURE PUMP DOES NOT ENGAGE

PROBABLE CAUSE	SOLUTION
Pressure pump circuit breaker has been tripped.	Check the pressure pump circuit breaker on the control panel. Press the circuit breaker reset button.
Defective electrical connection in the console wiring or defective switch.	Examine switch, electrical connections, and wiring. Repair any defective connections. If there is power going to the switch but not going out, replace the defective switch.
Pressure pump has not been activated.	Turn pressure pump switch to on.
Defective pressure pump clutch.	If there is power in the switch, but not power at the clutch, replace the defective wire. If there is power at the clutch, replace the defective switch.
Loose or broken pressure pump belts.	Tighten or replace belts.

CHEMICAL SYSTEM TROUBLESHOOTING

CHEMICAL FLOW METER INDICATES FLOW WITH TOOL VALVE CLOSED

PROBABLE CAUSE	SOLUTION
External leak in chemical piping.	Tighten or replace fittings. Re-apply thread sealant where required.
Outlet check valve is full of debris or damaged, not allowing it to close properly.	Close the chemical valve on the instrument panel. If the flow meter does not indicate flow, remove debris or replace check valve, if necessary.
Chemical pump diaphragm is ruptured.	Close the chemical valve on the instrument panel. If the flow meter still indicates flow, replace the chemical pump diaphragm.
Internal leak in chemical valve causing continual flow through prime tube returning to container.	Tighten valve packing nut (see “General Service Adjustments”). Replace valve, if necessary.

LOSS OF CHEMICAL (CLEANING TOOL OPEN, NO CHEMICAL)

PROBABLE CAUSE	SOLUTION
Chemical pump is improperly primed.	Refer to chemical pump priming instructions.
The strainer at the inlet end of the chemical inlet line is clogged.	Unclog the strainer. If damaged, replace.
Suction leak in the inlet line leading into the chemical pump.	Inspect inlet lines and flow meter for air leaks or damage.
Chemical pump check valve(s) is clogged.	Remove any debris from the chemical check valve(s). Replace chemical check valve(s) or seals, if necessary.
Chemical prime/on-off valve or chemical metering valve is defective.	Replace valve(s).
Chemical pump diaphragm is ruptured.	Disassemble the chemical pump and replace the damaged diaphragm.
Defective cylinder in the pressure pump.	Measure the pump volume. If the pump volume is less than normal, refer to “Loss of Solution Volume” in this section.

HEAT EXCHANGER/TEMPERATURE RELATED TROUBLESHOOTING**EXCESSIVE HEATING**

PROBABLE CAUSE	SOLUTION
Flow restriction caused by hard water scaling.	Descale unit, repair or replace damaged plumbing components as necessary. Install a water softener.
Thermal relief valve stuck.	Check thermal relief valve for scaling or debris.
Not enough water flowing during normal operation.	Check jet size of tool. Do not let cleaning tool sit for long periods with unit running. Trigger tool more often.
Bypass manifold orifice clogged.	Clean orifice.

LOSS OF TEMPERATURE

PROBABLE CAUSE	SOLUTION
No vacuum hose is connected.	Connect vacuum hose to vacuum inlet port.
Temperature relief valve on water box is stuck open.	Clean temperature relief valve and test. Replace if necessary.
Engine RPM is low.	Reset engine RPM.
Defective temperature gauge.	Test gauge and sensor. Replace failed component.
Temperature balance orifice missing.	Replace orifice.
Manual inlet bypass valve open.	Close valve, check for leaks. Replace if leaking.

HEAT EXCHANGER LEAKING

PROBABLE CAUSE	SOLUTION
Water is dripping from the exhaust port due to condensation build-up.	NOTE: The heat exchanger may produce water condensation discharge at times during normal operation. Do not confuse this with a leak.
Heat exchanger is damaged from frozen water.	Inspect heat exchanger for leaks. Visually inspect for damage. Pressure check after removing the unit (maximum test pressure – 1500 PSI).

WASTE PUMP (IF INSTALLED) TROUBLESHOOTING**WASTE PUMP NOT OPERATING NORMALLY**

PROBABLE CAUSE	SOLUTION
Defective waste pump float switch.	Replace float switch.
Inspect check valve for debris or damage.	Clean or replace if necessary. Ensure that check valves are seated correctly by extending the spring.
Broken diaphragm(s).	Replace diaphragm(s).
Weak battery.	Charge or replace battery if needed. Check charging station.
Pump-out circuit breaker on control panel has been tripped.	After inspecting waste pump to determine the cause of the tripped circuit breaker, press the reset button.

SECTION FIVE: PARTS LISTING AND REFERENCE

CONSOLE ASSEMBLY	61
FRAME AND ENCLOSURES	63
FRONT BEZEL ASSEMBLY	67
LOWER FRONT PANEL ASSEMBLY	68
BELT GUARD ASSEMBLY	69
INSTRUMENT PANEL ASSEMBLY	70
CONTROL PANEL ASSEMBLY	73
ENGINE ASSEMBLY	74
THROTTLE CONTROL ASSEMBLY	79
VACUUM PUMP ASSEMBLY	80
VACUUM RELIEF VALVE ASSEMBLY	81
PRESSURE PUMP ASSEMBLY	82
CHEMICAL PUMP	84
EXHAUST HEAT EXCHANGER ASSEMBLY	85
COOLANT HEAT EXCHANGER ASSEMBLY	87
WATER BOX ASSEMBLY	88
PRESSURE REGULATOR ASSEMBLY	90
SOLUTION MANIFOLD ASSEMBLY	91
BYPASS MANIFOLD ASSEMBLY	93
WATER/VACUUM INLET BRACKET ASSEMBLY	94
90 GALLON WASTE TANK	95
120 GALLON WASTE TANK	97
WASTE TANK PORTS KIT	99
WASTE TANK HOSES KIT	100
FUEL PUMP KIT	101
FUEL PUMP AND HOUSING ASSEMBLY	102
BULKHEAD FUEL FITTING/LINE ASSEMBLY	103
DECALS	104
WIRING DIAGRAM	105
HOSE ROUTING/FLOW DIAGRAM	106
FUEL HOOK-UP KITS	108

SECTION FIVE: PARTS LISTING AND REFERENCE

70-500, CONSOLE, PEAK 500

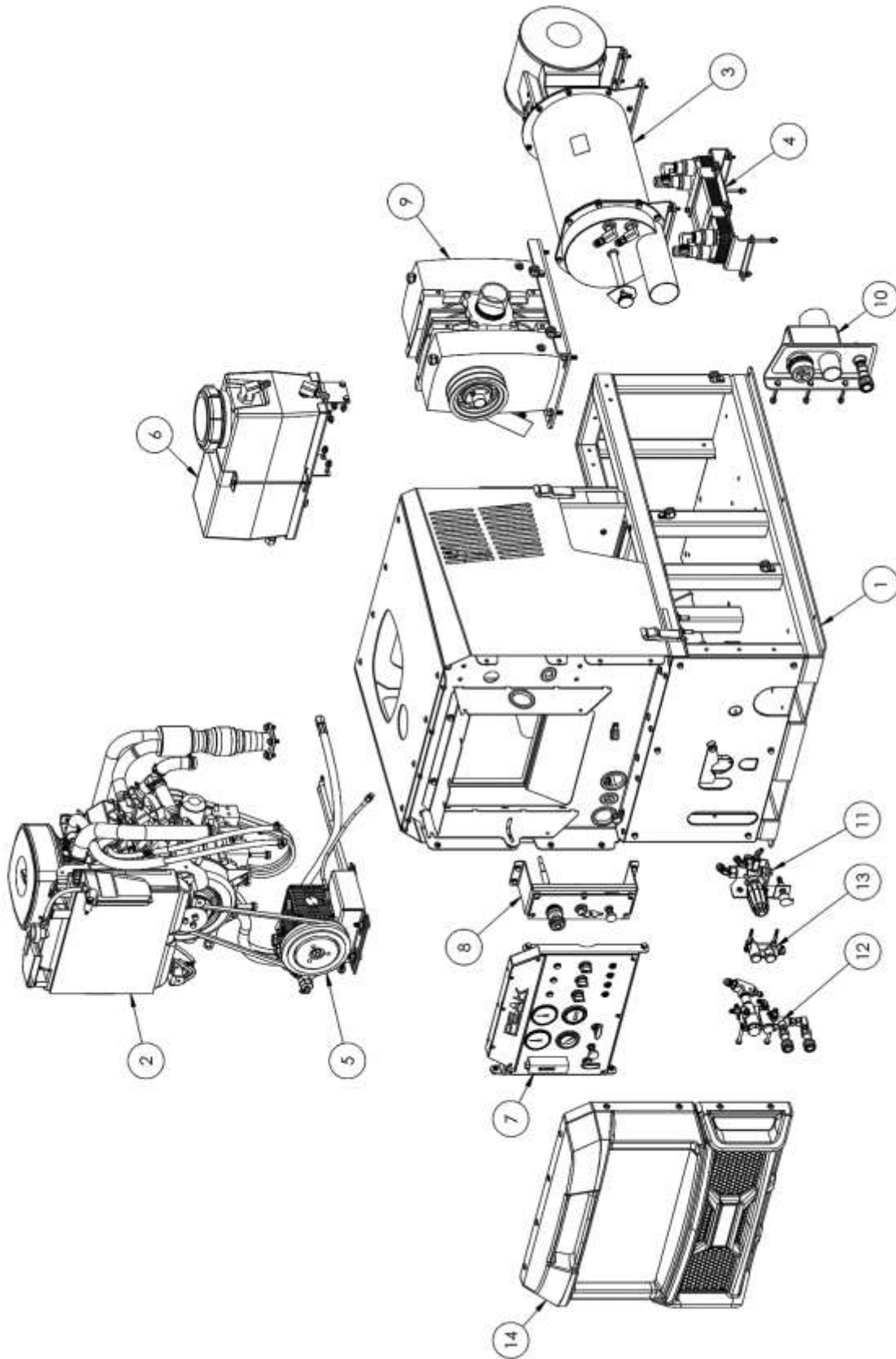

SECTION FIVE: PARTS LISTING AND REFERENCE

70-500, CONSOLE, PEAK 500 BOM TABLE

1	24	44-079	DECAL, WARNING, UNLEADED FUEL ONY
1	23	44-081	DECAL, ENGINE COVER WARRANTY
1	22	44-066	DECAL,WARNING ELECTRICAL SHOCK
1	21	44-082	DECAL, DANGER ROTATING MACHINERY
1	20	44-062	TAG, MAX VAC 13 HG
1	19	44-313	DECAL, SERIAL
1	18	44-095	DECAL, ENGINE OIL DRAIN
1	17	44-085	DECAL, WARNING ROTATING MACHINERY
1	16	44-084	DECAL, CAUTION HOT SURFACE
1	15	44-083	DECAL, WARNING HIGH PRESSURE
1	14	69-978	ASSY, THERMOFORMED BEZEL
1	13	69-972	ASSY, BYPASS MANIFOLD
1	12	69-971	ASSY, SOLUTION MANIFOLD
1	11	69-958	ASSY, PRESSURE REGULATOR
1	10	69-956	ASSY, WTR-VAC INLET
1	9	69-955	ASSY, VACUUM PUMP
1	8	69-952	ASSY, CONTROL PANEL
1	7	69-950	ASSY, INSTRUMENT PANEL
1	6	69-980	ASSY, WATER BOX
1	5	69-917	ASSY, PRESSURE PUMP
1	4	69-973	ASSY, COOLANT HEAT EXCHANGER
1	3	69-951	ASSY, EXHAUST HE PEAK
1	2	69-954	ASSY, ENGINE
1	1	69-949	ASSY, FRAME & ENCLOSURES
QTY	ITEM	PART NO.	DESCRIPTION

1	EA	47-163	HARNESS, PEAK 500
1	EA	49-169	MANUAL, PEAK 500
1	EA	69-000	ASSY, LEVEL SENSOR SHTOFF
QTY	U/M	PART NO.	DESCRIPTION
ITEMS NOT SHOWN IN DRAWING VIEWS			

SECTION FIVE: PARTS LISTING AND REFERENCE

69-949, FRAME AND ENCLOSURES

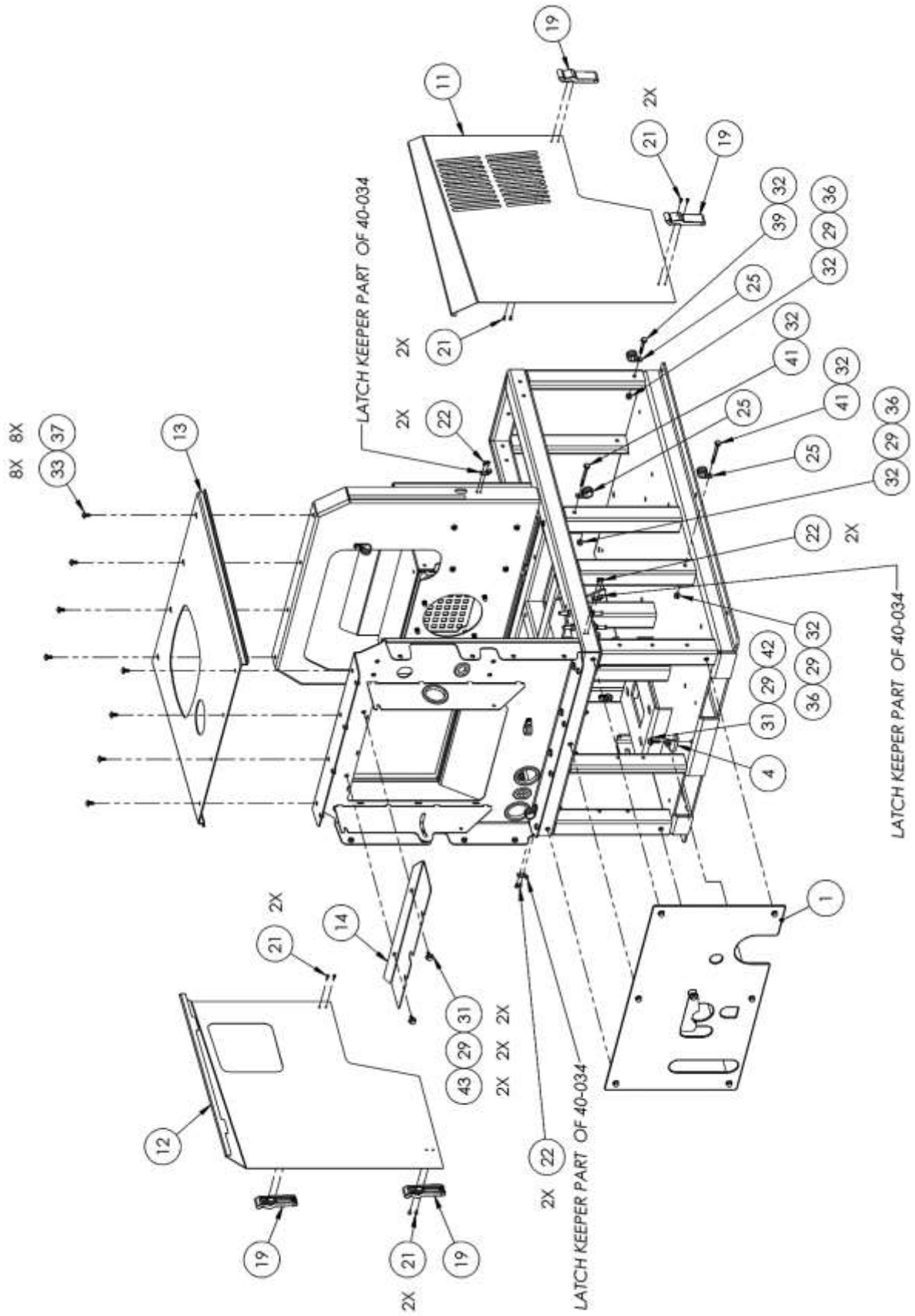

69-949, FRAME AND ENCLOSURES

SECTION FIVE: PARTS LISTING AND REFERENCE

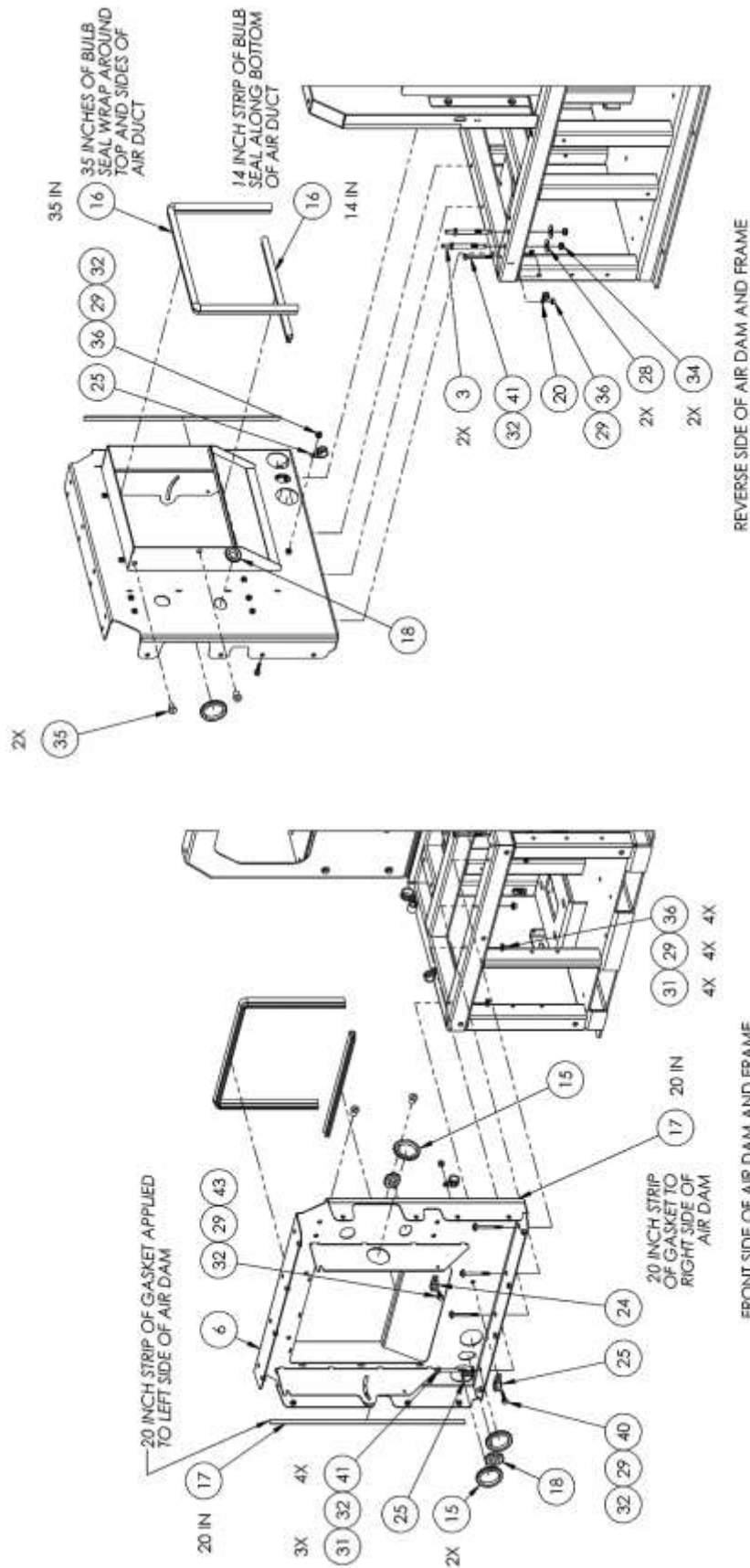

69-949, FRAME AND ENCLOSURES

SECTION FIVE: PARTS LISTING AND REFERENCE

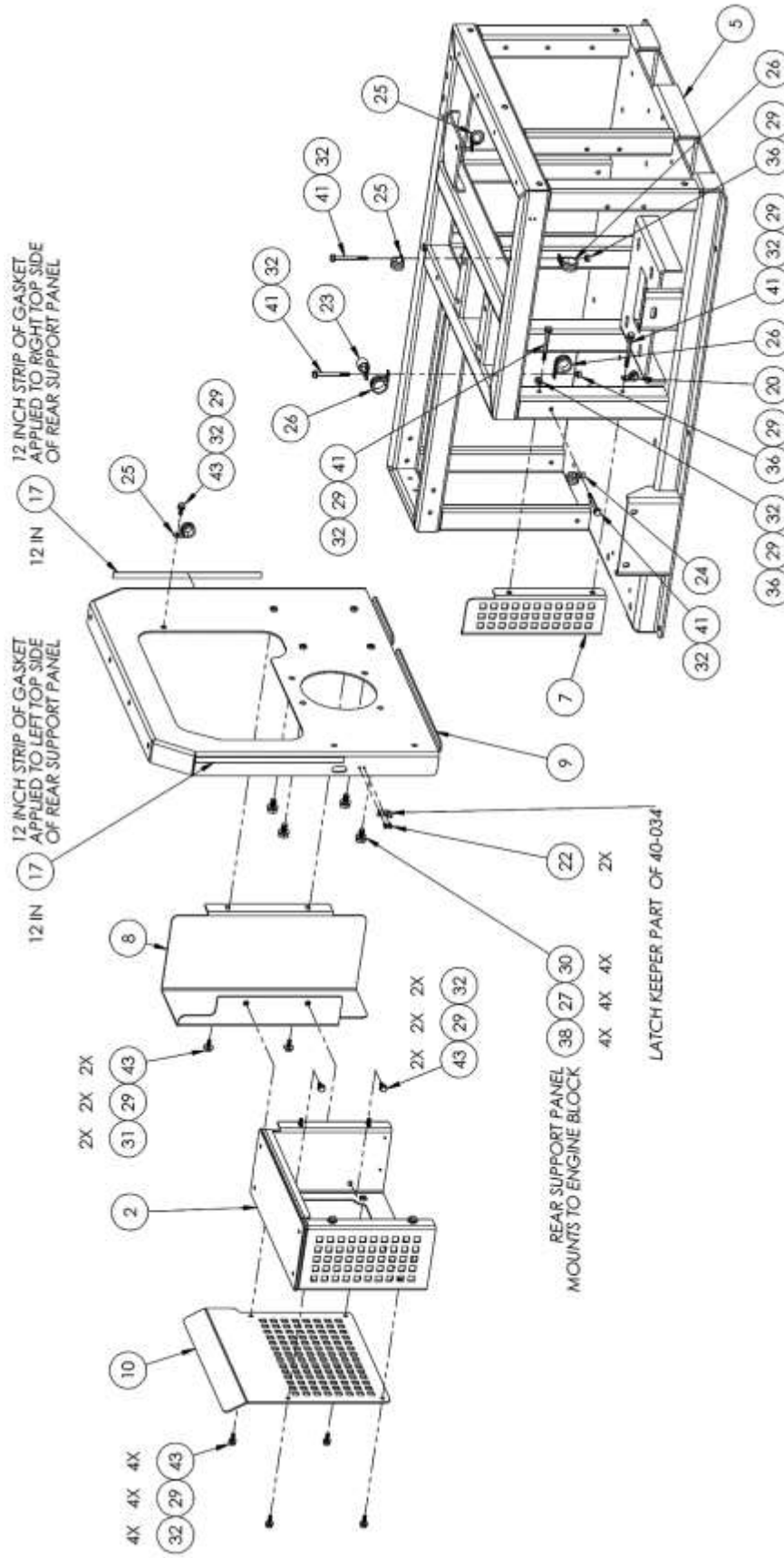

SECTION FIVE: PARTS LISTING AND REFERENCE
69-949, FRAME AND ENCLOSURES BOM TABLE

12	43	10-025	SCREW, MACH 1/4-20 X 3/4 HXHD GRD5
1	42	10-026	SCREW, MACH 1/4-20 X 1 HXHD
12	41	10-028	SCREW, MACH 1/4-20 X 2-3/4 HXHD
1	40	10-042	SCREW, MACH, 1/4-20 X 1-1/4 HXHD ZINC
1	39	10-170	SCREW, MACH, 1/4-20 X 1-3/4 HH G5
4	38	10-241	SCREW, MACH M10-1.5 X 20MM HXHD Z
8	37	10-420	SCREW, MACH 1/4-20 X 5/8 BHSCS ZP
12	36	11-004	NUT, 1/4-20 ZINC
2	35	11-072	NUT, WELL 1/4-20 X .187 RUBBER
2	34	11-088	NUT, 7/16-20 THIN NYLOK ZPS
8	33	12-002	WASHER, FLAT 1/4 SS ANC
24	32	12-011	WASHER, FLAT #12 SAE
12	31	12-012	WASHER, FLAT 1/4 USS
4	30	12-013	WASHER, FLAT 3/8 USS
28	29	12-015	LKWSR, 1/4 ZINC
2	28	12-021	WASHER, FLAT, 7/16 ZINC
4	27	12-024	LKWSR, 10MM ZINC
3	26	14-003	CLAMP,WIRE CUSHION 1.00 ID X 1/4 BOLT
9	25	14-004	CLAMP,WIRE CUSHION 3/4 ID X 1/4 BOLT
2	24	14-005	CLAMP,WIRE CUSHION 5/8 ID X 1/4 BOLT
1	23	14-023	CLAMP, 3/4 ID VINYL COVERED
8	22	14-085	RIVET, 5/32 X .312 HD .251-.375 GRIP SS
8	21	14-086	RIVET, 5/32 X .312 HD .062-.125 GRIP SS
2	20	14-107	CLAMP,WIRE CUSHION 3/8 X 1/4 BOLT
4	19	40-034	LATCH, DRAW SS CONCEALED MOUNT
2	18	41-033	GROMMET, 1 ID X 1-3/4OD
5.33 FT	17	41-112	GASKET, VINYL SPONGE W/PSA
4.08 FT	16	41-190	TRIM, BULB SEAL .125THK .625 BULB BLK
3	15	41-204	GROMMET, 2.0 ID X 2-5/8 OD X 1/8 PANEL
1	14	58-1015	PNL, AIR BAFFLE
1	13	58-1016	PNL, TOP HOOD
1	12	58-1017	PNL, LEFT SIDE HOOD
1	11	58-1018	PNL, RIGHT SIDE HOOD
1	10	60-3213	PNL, BELT GUARD COVER
1	9	61-1581	WMT, REAR SUPPORT
1	8	61-1582	WMT, HEAT SHIELD
1	7	61-1584	WMT, LOWER REAR BELT GUARD
1	6	61-1590	WMT, FRONT SUPPORT
1	5	62-008	ASSY, FINISHED FRAME PEAK
1	4	62-010	ASSY, FRONT PANEL BRACKET
2	3	66-360	FITTING, 5/16 FUEL LINE MANIFOLD
1	2	69-969	ASSY, BELT GUARD
1	1	69-985	ASSY, LOWER PANEL
QTY	ITEM	PART NO.	DESCRIPTION

SECTION FIVE: PARTS LISTING AND REFERENCE
69-978, FRONT BEZEL ASSEMBLY

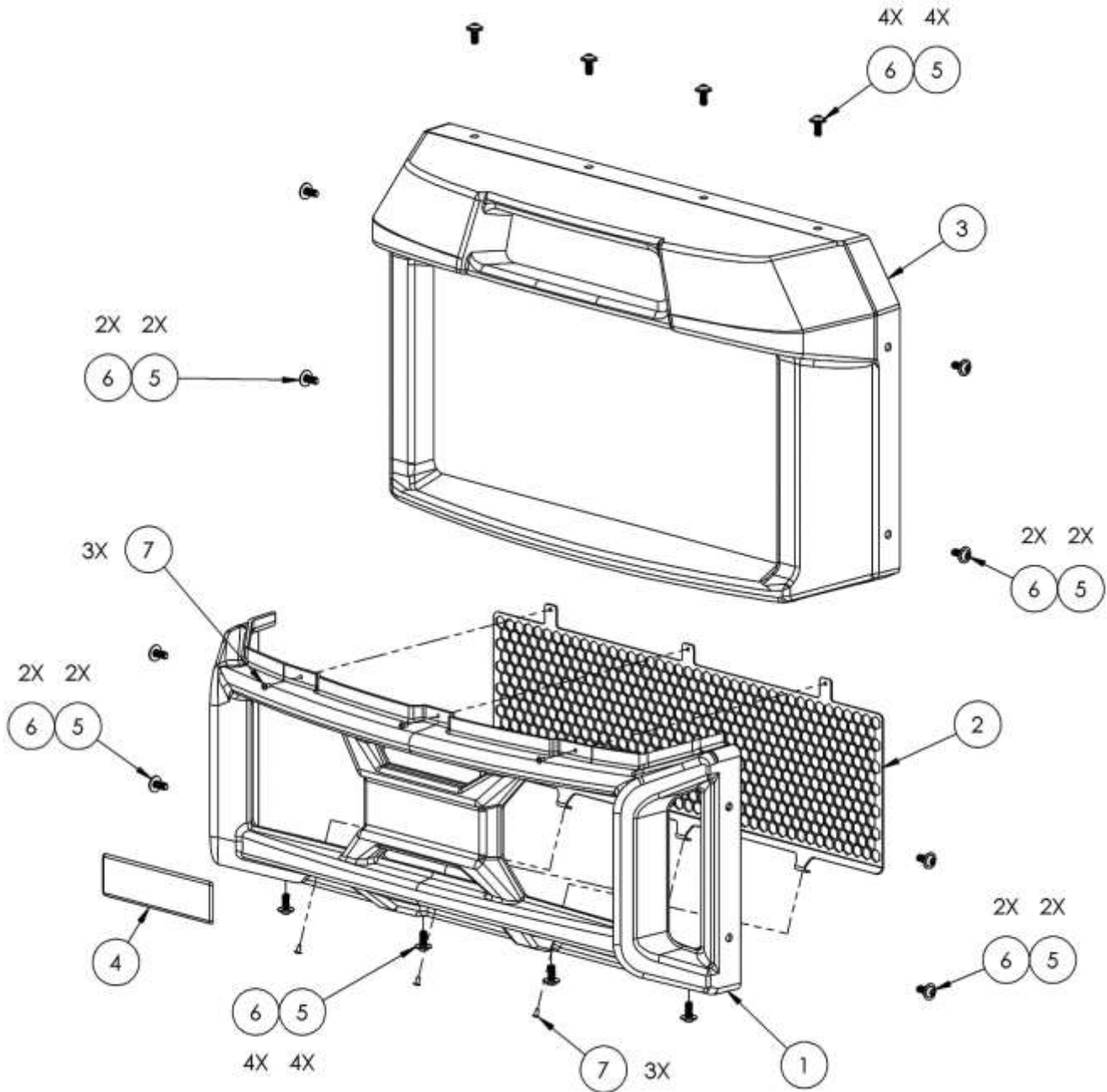

6	7	14P-120	RIVET, 1/8 X .25 HD .126-.187 GRIP ALUM BLK
16	6	10-420	SCREW, MACH 1/4-20 X 5/8 BHSCS ZP
16	5	12-002	WASHER, FLAT 1/4 SS ANC
1	4	44-324	DECAL, 500 EMBLEM
1	3	51-121	THERMOFORM, UPPER BEZEL
1	2	58-1021	PNL, LOWER GRILLE
1	1	51-122	THERMOFORM, LOWER BEZEL
QTY	ITEM	PART NO.	DESCRIPTION

SECTION FIVE: PARTS LISTING AND REFERENCE
69-985, LOWER FRONT PANEL ASSEMBLY

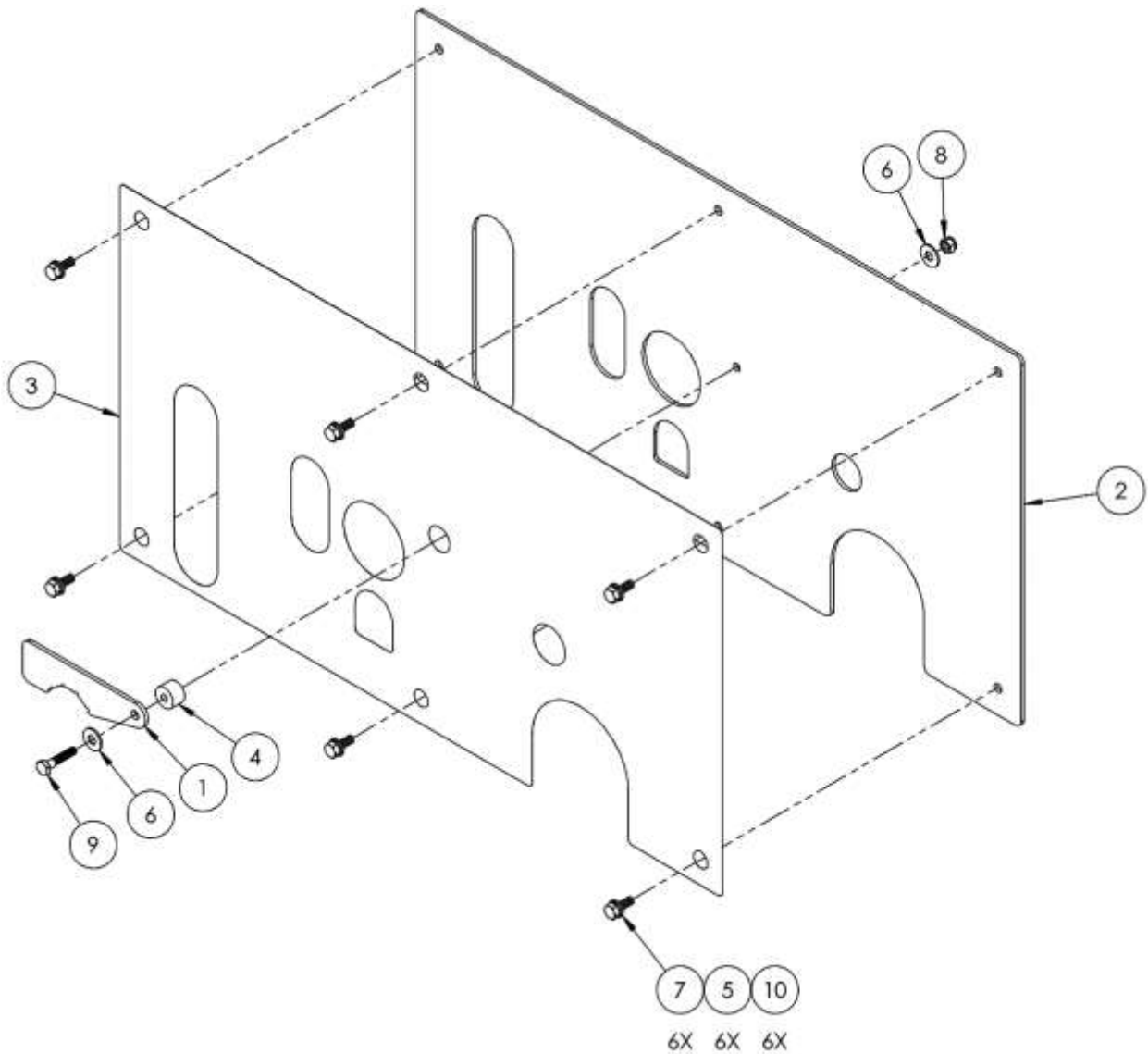

6	10	10-025	SCREW, MACH 1/4-20 X 3/4 HXHD GRD5
1	9	10-042	SCREW, MACH, 1/4-20 X 1-1/4 HXHD ZINC
1	8	11-013	NUT, 1/4-20 NYLOK SS
6	7	12-011	WASHER, FLAT #12 SAE
2	6	12-012	WASHER, FLAT 1/4 USS
6	5	12-015	LKWSR, 1/4 ZINC
1	4	12-082	SPACER, .75 OD X .26 ID X .50 L LDPE
1	3	44-325	DECAL, LOWER FRONT
1	2	58-1004	PNL, LOWER FRONT
1	1	58-1009	LEVER, REGULATOR STOP
QTY	ITEM	PART NO.	DESCRIPTION

SECTION FIVE: PARTS LISTING AND REFERENCE
69-969, BELT GUARD ASSEMBLY

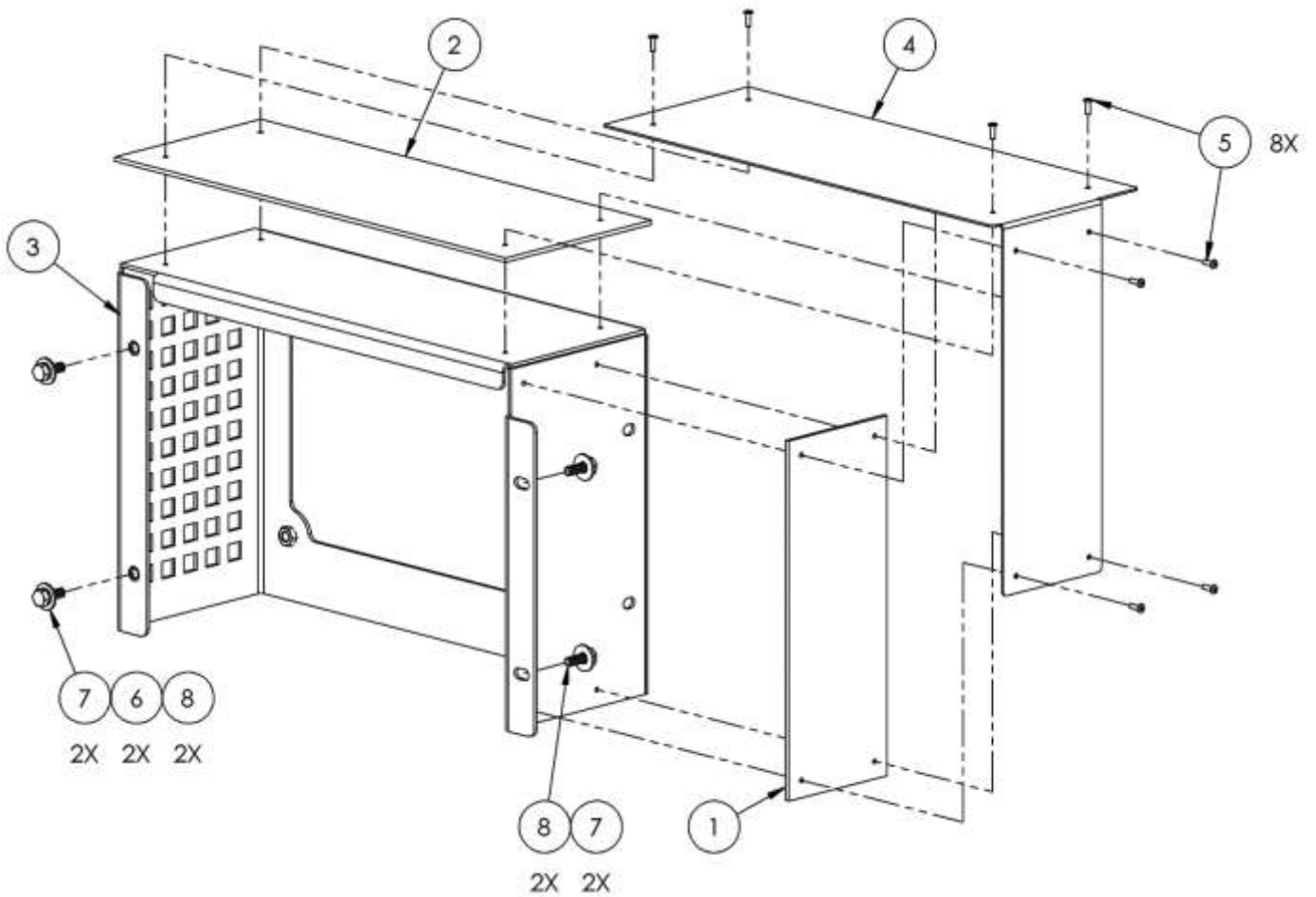

4	8	10-025	SCREW, MACH 1/4-20 X 3/4 HXHD GRD5
4	7	12-012	WASHER, FLAT 1/4 USS
4	6	12-015	LKWSR, 1/4 ZINC
8	5	14-019	RIVET, ALUM NAMEPLATE
1	4	58-1011	PNL, BELT GUARD SHIELD
1	3	61-1583	WMT, REAR BELT GUARD
1	2	64-073	INSULATOR, BELT GUARD TOP
1	1	64-074	INSULATOR, BELT GUARD SIDE
QTY	ITEM	PART NO.	DESCRIPTION

SECTION FIVE: PARTS LISTING AND REFERENCE

69-950, INSTRUMENT PANEL ASSEMBLY

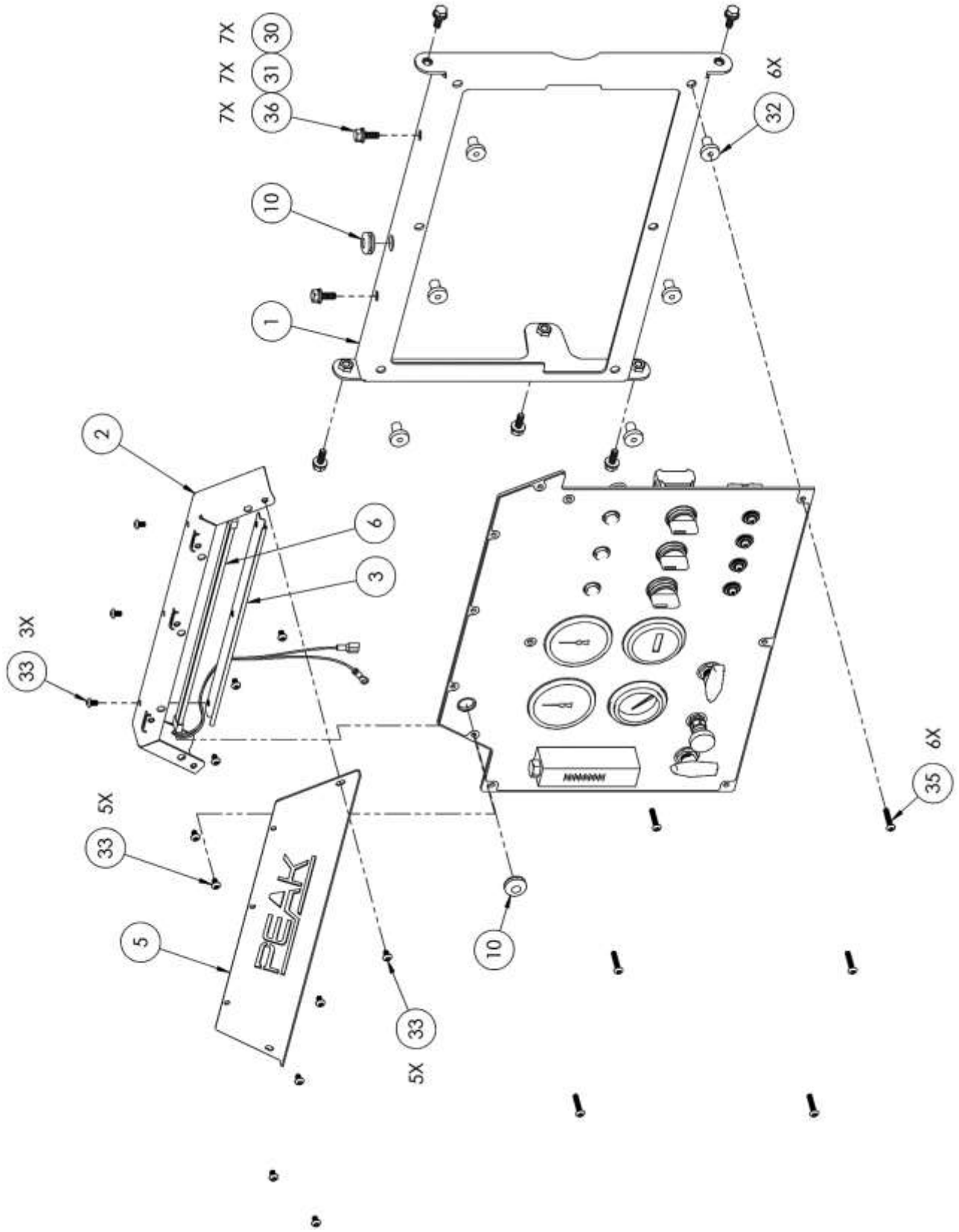

69-950, INSTRUMENT PANEL ASSEMBLY

SECTION FIVE: PARTS LISTING AND REFERENCE

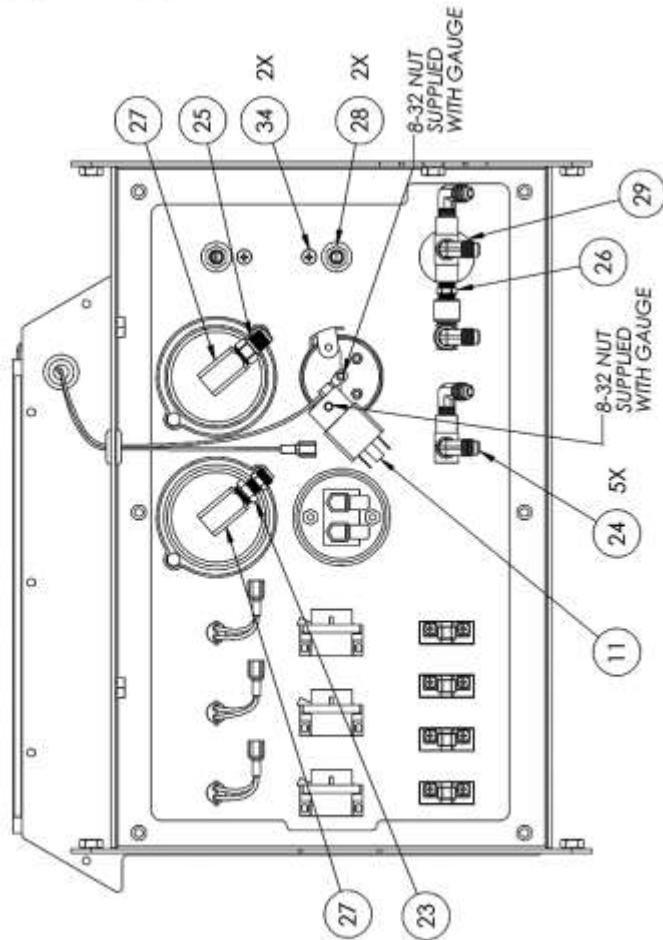
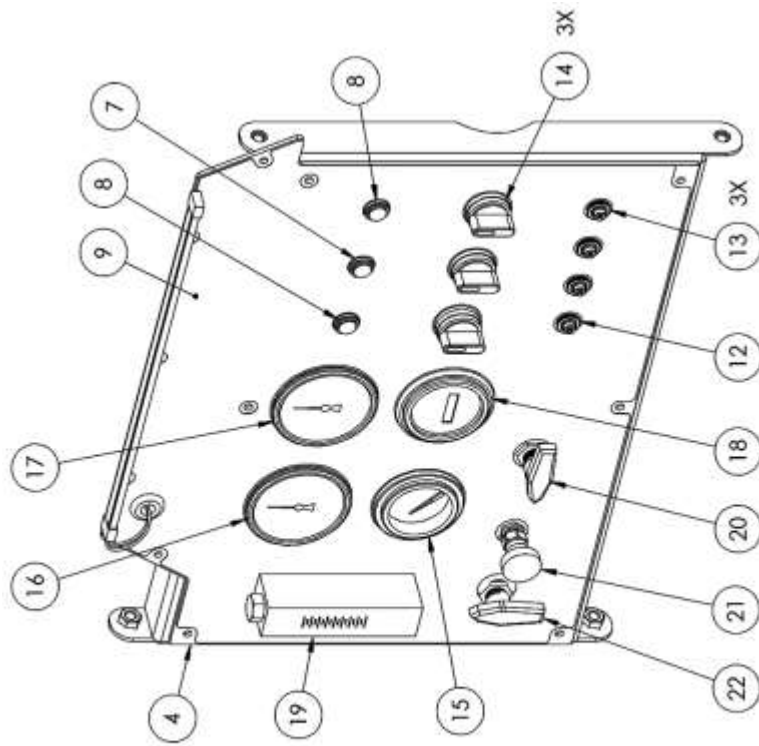

SECTION FIVE: PARTS LISTING AND REFERENCE
69-950, INSTRUMENT PANEL ASSEMBLY BOM TABLE

7	36	10-025	SCREW, MACH 1/4-20 X 3/4 HXHD GRD5
6	35	10-181	SCREW, MACH 10-32 X 1 BHSCS SS
2	34	10-275	SCREW, MACH 10-32 X 1/4 PHP ZP
13	33	10P-419	SCREW, 10-32 X 5/16 BHSCS W-NYLON PATCH
6	32	11-002	NUT, WELL G 10-32
7	31	12-011	WASHER, FLAT #12 SAE
7	30	12-015	LKWSR, 1/4 ZINC
1	29	12-018	WASHER, FLAT 1/2 USS
2	28	21-007	FTTG, BRB 1/8 P X 5/16 H BR
2	27	21-037	ELL, 1/4 IN. BRASS
1	26	21-045	NIP, 1/8 IN HEX BRASS
1	25	21-050	CONN, 1/4 NPT X 1/4 JIC BRASS
5	24	21-054	ELL, 1-8P X 1/4 T BRASS
1	23	21-433	CONN, 1/4 P X 1/4 POLY
1	22	23-027	VALVE, 3-WAY BALL 1/8 FP SS
1	21	23-028	VLV, MET 1/8 FP (CHEM) RT ANG SS
1	20	23-138	VALVE, 2-WAY BALL 1/8 FP SS
1	19	26-003	FLOWMETER, 1/8 FP
1	18	26-033	HOURMETER, HOBBS CHROME BEZEL
1	17	26-044	GAUGE, VACUUM 2.5 IN 0-30 IN/HG
1	16	26-045	GAUGE, PRESSURE 2.5 IN 0-1500 PSI
1	15	26-049	GAUGE, WTR TEMP CHROME 280 DEG.
3	14	29-016	SWITCH, ROTARY NON-ILLUMINATED
3	13	30-149	BREAKER, 20A SCREW TERM
1	12	30-150	BREAKER, 30A SCREW TERM
1	11	34-010	RELAY, ENG.SHTDWN 12V 40/60AMP
2	10	41-070	GROMMET, 7/8" OD X 3/8" ID X 1/8" PANEL
1	9	44-326	DECAL, INSTRUMENT PANEL
2	8	47-164	LIGHT ASSY, RED INDICATOR
1	7	47-165	LIGHT ASSY, AMBER INDICATOR
1	6	47-166	LIGHT ASSY, BLUE LED STRIP
1	5	58-1014	PLT, PEAK NAMEPLATE
1	4	58-999	PLT, INSTRUMENT PANEL
1	3	61-1499	WELDMENT, LED STRIP MOUNT
1	2	61-1569	WELDMENT, BEZEL LIGHT & NP BRKT
1	1	61-1592	WMT, INSTRUMENT PANEL SUPPORT
QTY	ITEM	PART NO.	DESCRIPTION

SECTION FIVE: PARTS LISTING AND REFERENCE
69-952, CONTROL PANEL ASSEMBLY

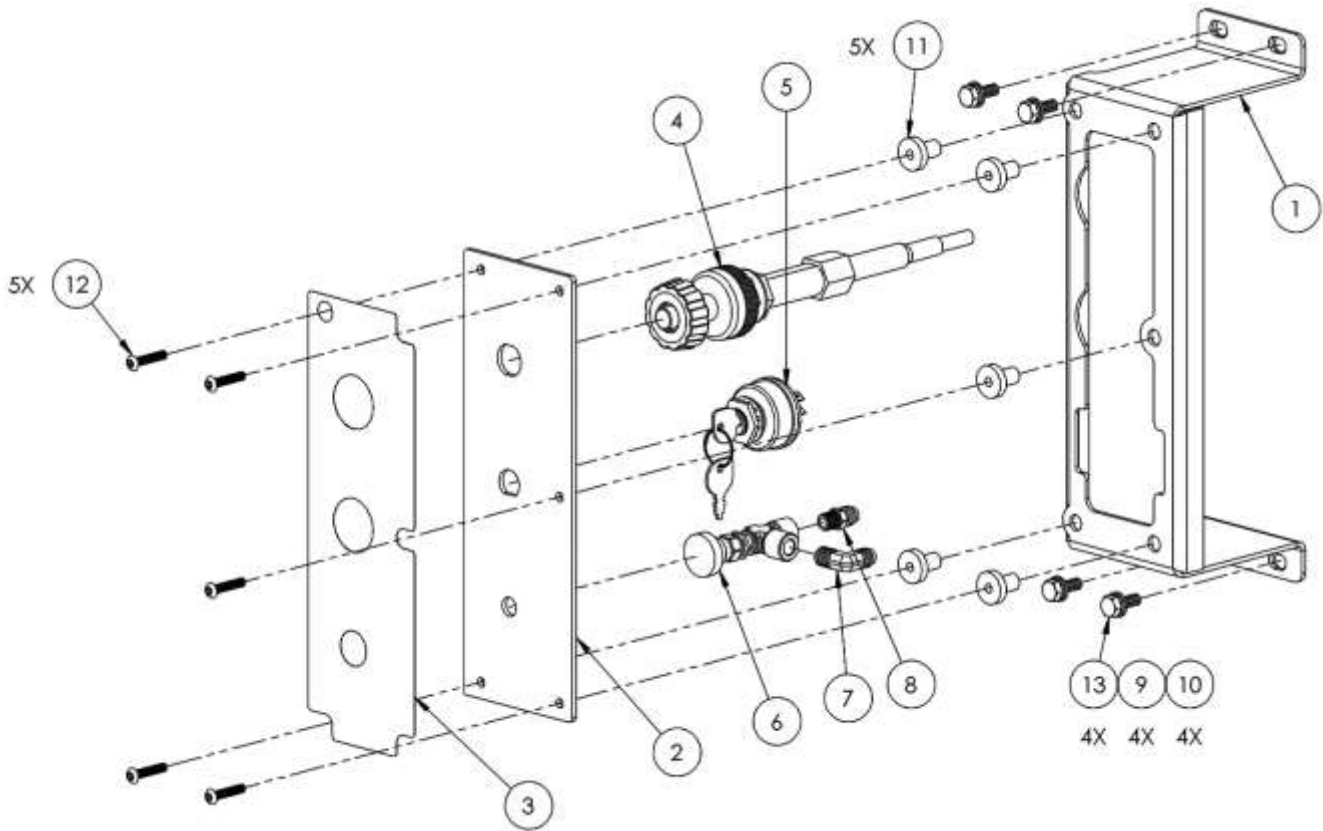

4	13	10-025	SCREW, MACH 1/4-20 X 3/4 HXHD GRD5
5	12	10-181	SCREW, MACH 10-32 X 1 BHSCS SS
5	11	11-002	NUT, WELL G 10-32
4	10	12-011	WASHER, FLAT #12 SAE
4	9	12-015	LKWSR, 1/4 ZINC
1	8	21-001	CONN, 1/8 P X 1/4 T BR
1	7	21-054	ELL, 1-8P X 1/4 T BRASS
1	6	23-028	VLV, MET 1/8 FP (CHEM) RT ANG SS
1	5	29-047	SWITCH, BRIGGS & STRATTON
1	4	40-031	CABLE, THROTTLE
1	3	44-327	DECAL, CONTROL PANEL
1	2	58-1002	PLT, CONTROL PANEL
1	1	61-1591	WMT, CONTROL PANEL SUPPORT
QTY	ITEM	PART NO.	DESCRIPTION

69-954, ENGINE ASSEMBLY

SECTION FIVE: PARTS LISTING AND REFERENCE

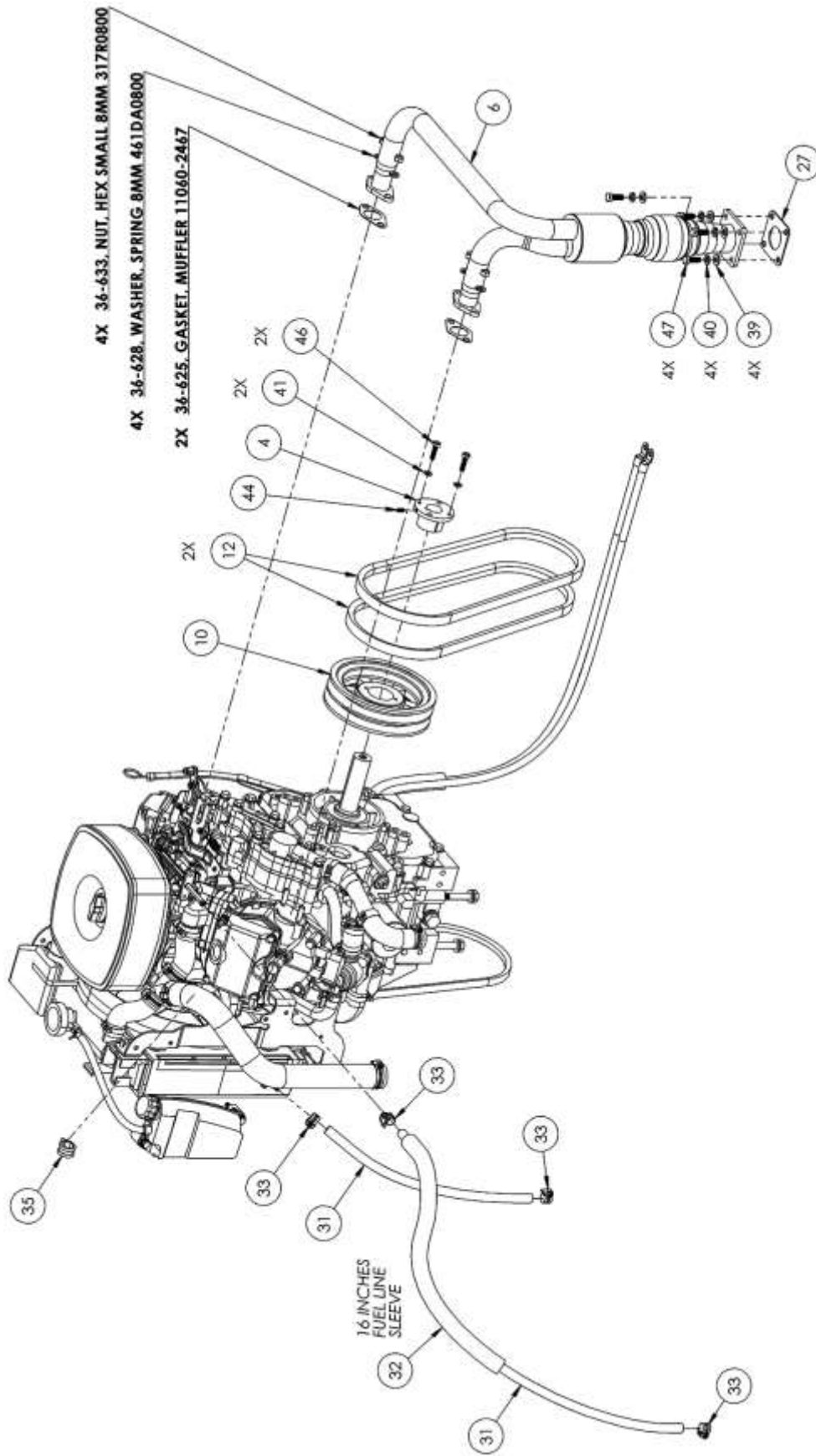

69-954, ENGINE ASSEMBLY

SECTION FIVE: PARTS LISTING AND REFERENCE

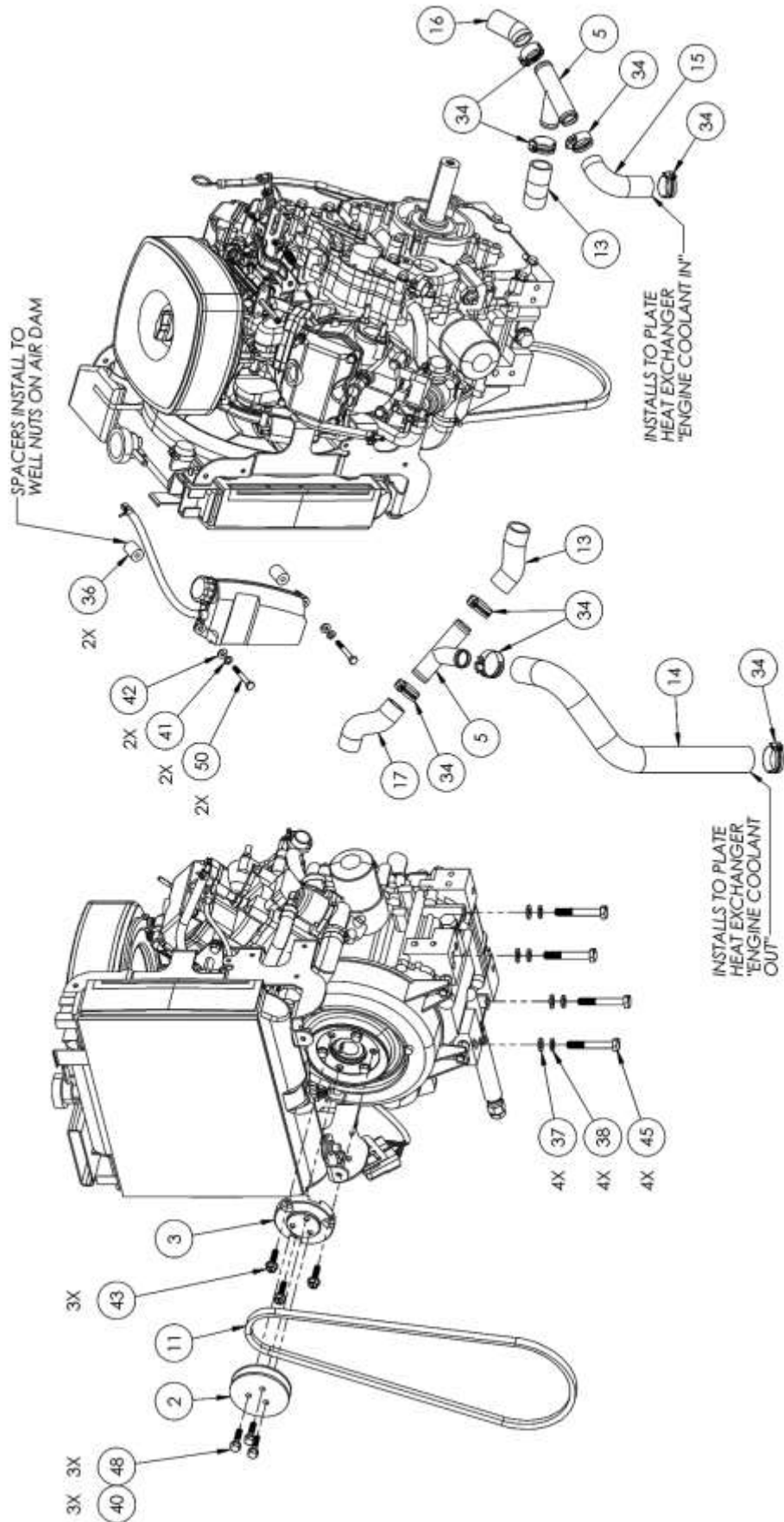

SECTION FIVE: PARTS LISTING AND REFERENCE
69-954, ENGINE ASSEMBLY

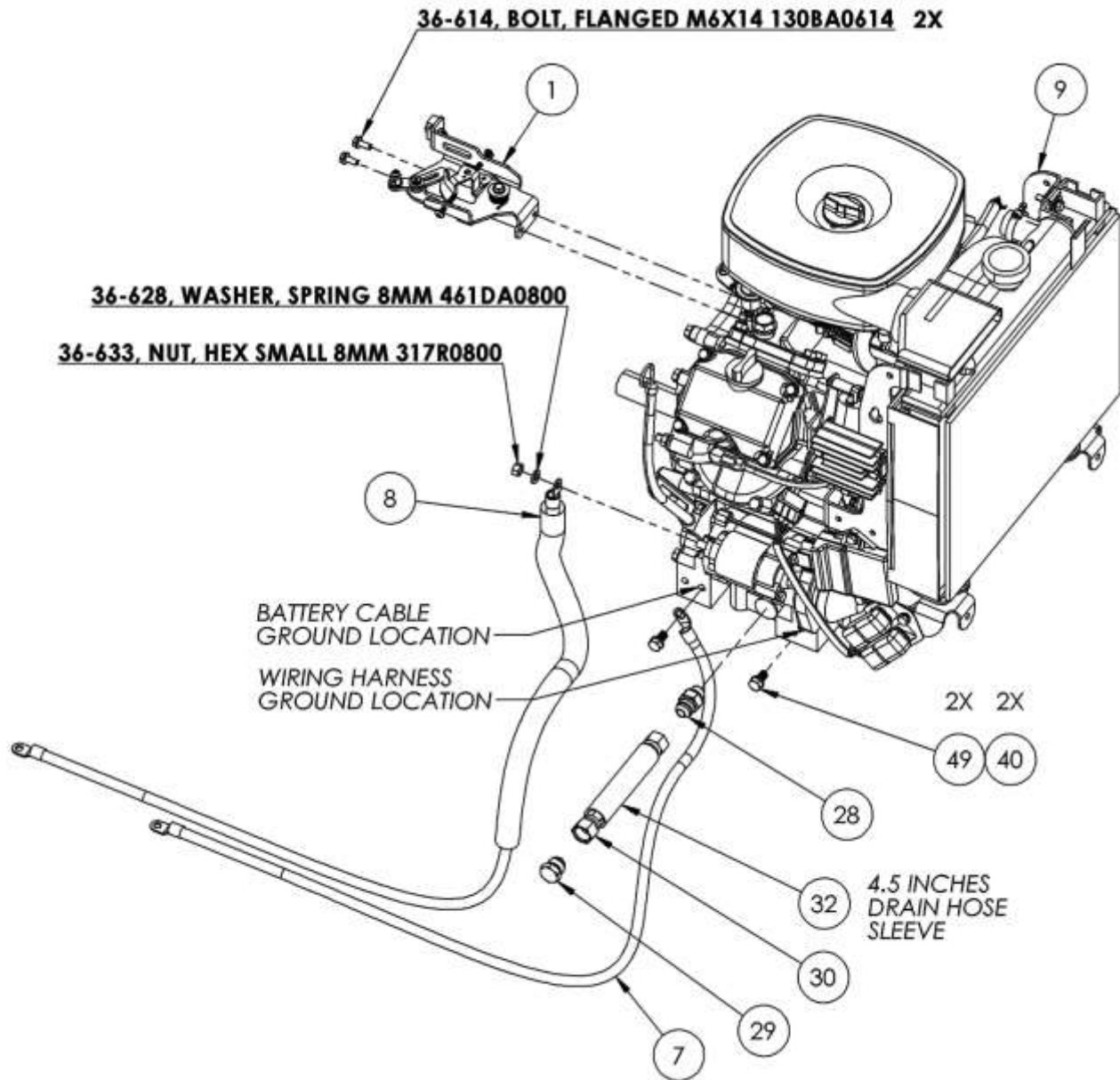

SERVICE PARTS NOT SHOWN IN DRAWING VIEWS:

- 36-643, FILTER, OIL 49065-2071
- 36-644, SPARK PLUG, BPR4ES SOLID
- 36-645, BELT, COOLING FAN 59011-2056
- 36-646, SCREEN, RADIATOR 14037-2142
- 36-647, CAP, RESERVOIR 11012-1084

69-954, ENGINE ASSEMBLY

SECTION FIVE: PARTS LISTING AND REFERENCE

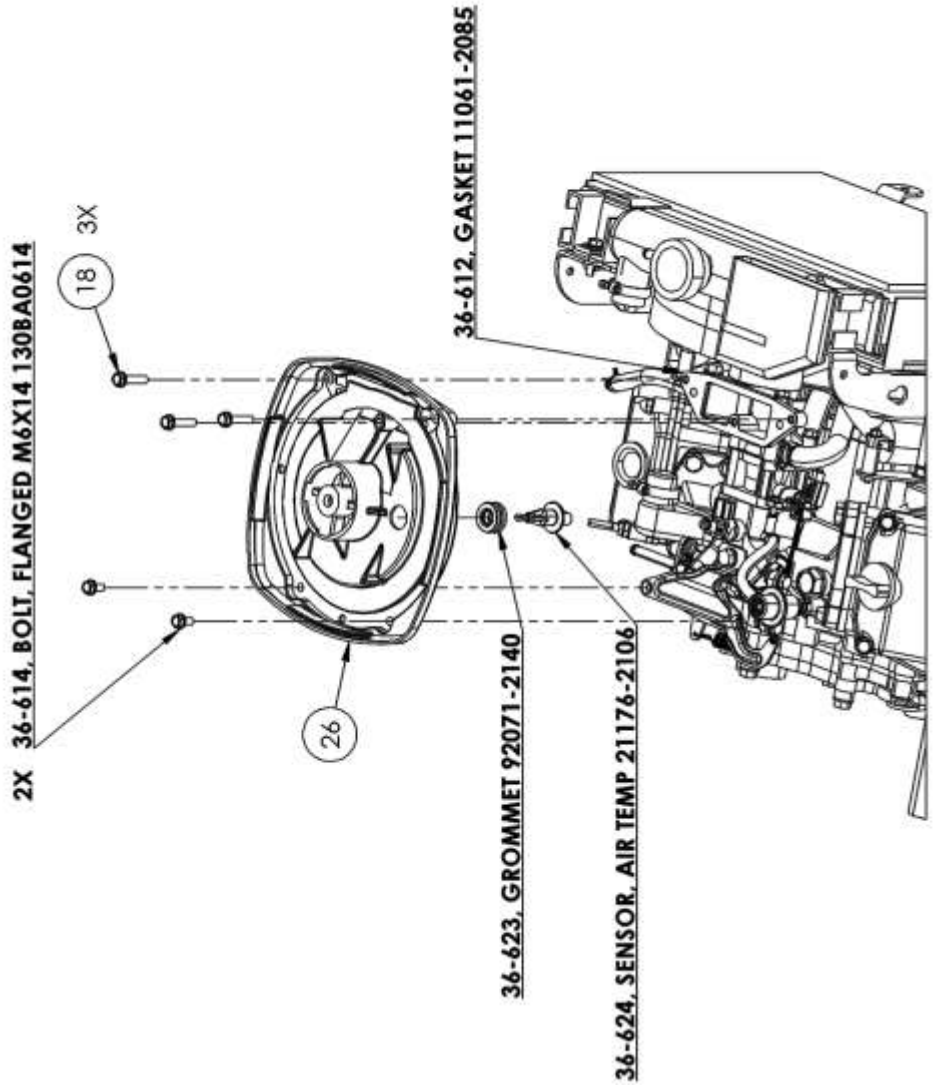
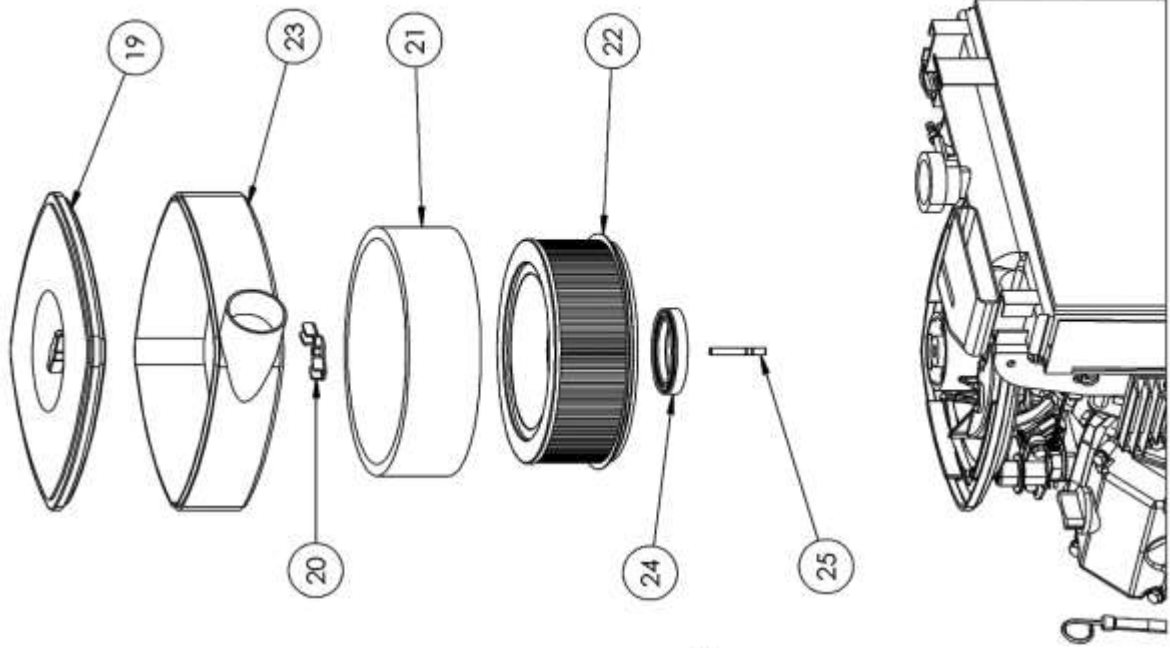

SECTION FIVE: PARTS LISTING AND REFERENCE
69-954, ENGINE ASSEMBLY BOM TABLE

2	50	10-005	SCREW, MACH, 1/4-20 X 2 HXHD
2	49	10-008	SCREW, MACH 8MM-16 X 1.25MM
3	48	10-036	SCREW, MACH 5/16-18 X 1-1/4 HXHD
4	47	10-119	BOLT, 5/16-18 X 7/8 HHCS
2	46	10-175	SCREW, MACH 1/4-20 X 1 HXHD YZ8
4	45	10-187	SCREW, M10-1.5 X 70MM Z HXHD G8.8
1	44	10-356	SCREW, SET 10-32 X .5 CP SOCHD BLK
3	43	10-427	BOLT, HEX FLANGE M8-1.25 X 30MM YZP
2	42	12-011	WASHER, FLAT #12 SAE
4	41	12-015	LKWSR, 1/4 ZINC
9	40	12-016	LKWSR, 5/16 ZINC
4	39	12-017	WASHER, FLAT 5/16 SAE ZINC
4	38	12-024	LKWSR, 10MM ZINC
4	37	12-025	WASHER, FLAT M10
2	36	12-113	SPACER, .26 ID X .75 OD X 1 L LDPE
1	35	14-004	CLAMP,WIRE CUSHION 3/4 ID X 1/4 BOLT
8	34	14-006	CLAMP, HOSE #20 SS
4	33	14-007	CLAMP, HOSE #4
20.5 IN	32	16-028	SLEEVE, 1ID WOVEN NYLON BLACK
4.0 FT	31	16-103	HOSE, FUEL 5/16 30R9 FUEL INJECTION
1	30	18-355	HOSE ASSY, .38 ID X 08 FJIC X 6.5L
1	29	21-027	PLUG, 1/2 T BR
1	28	21-604	ADAPTER, 08 JIC X M16-1.5 SS
1	27	36-205	GASKET, ENGINE EXHAUST KUBOTA 31 HP
1	26	36-604	CASE, AIR FILTER 11011-2334
1	25	36-605	STUD, M6X30 92004-2152
1	24	36-606	SEAL, 92093-2123
1	23	36-607	CASE, AIR FILTER BODY 11011-2314
1	22	36-608	ELEMENT, AIR FILTER 11013-2213
1	21	36-609	ELEMENT, AIR FILTER 11013-2199
1	20	36-610	NUT 92210-2079
1	19	36-611	CASE, AIR FILTER UPPER 11011-2358
3	18	36-613	BOLT, FLANGED M6X30 130BA0630
1	17	36-626-01	HOSE, UPPER SEGMENT A
1	16	36-626-02	HOSE, LOWER SEGMENT B
1	15	36-627-01	HOSE, LOWER SEGMENT A
1	14	36-631	HOSE, RADIATOR UPPER
2	13	36-632	HOSE, BYPASS
2	12	37-123	BELT, BX41 GATES EPDM
1	11	37-124	BELT, AX43 GATES EPDM
1	10	38-050	SHEAVE, BROWNING 2BK70H
1	9	45-064	ENGINE, KAWASAKI FD851D-DFI
1	8	47-001	ASSY, BATTERY CABLE RED THERMAL
1	7	47-002	ASSY, BATTERY CABLE BLK THERMAL
1	6	61-1573	WMT, EXHAUST TUBES
2	5	61-1595	WMT, COOLANT Y ADAPTER
1	4	66-543	HUB, H X 1-1/8 W/SET SCREW
1	3	66-602	ADAPTER, FRONT PULLEY
1	2	66-604	PULLEY, ENGINE FRONT
1	1	69-963	ASSY, THROTTLE CONTROL
QTY	ITEM	PART NO.	DESCRIPTION

SECTION FIVE: PARTS LISTING AND REFERENCE
69-963, THROTTLE CONTROL ASSEMBLY

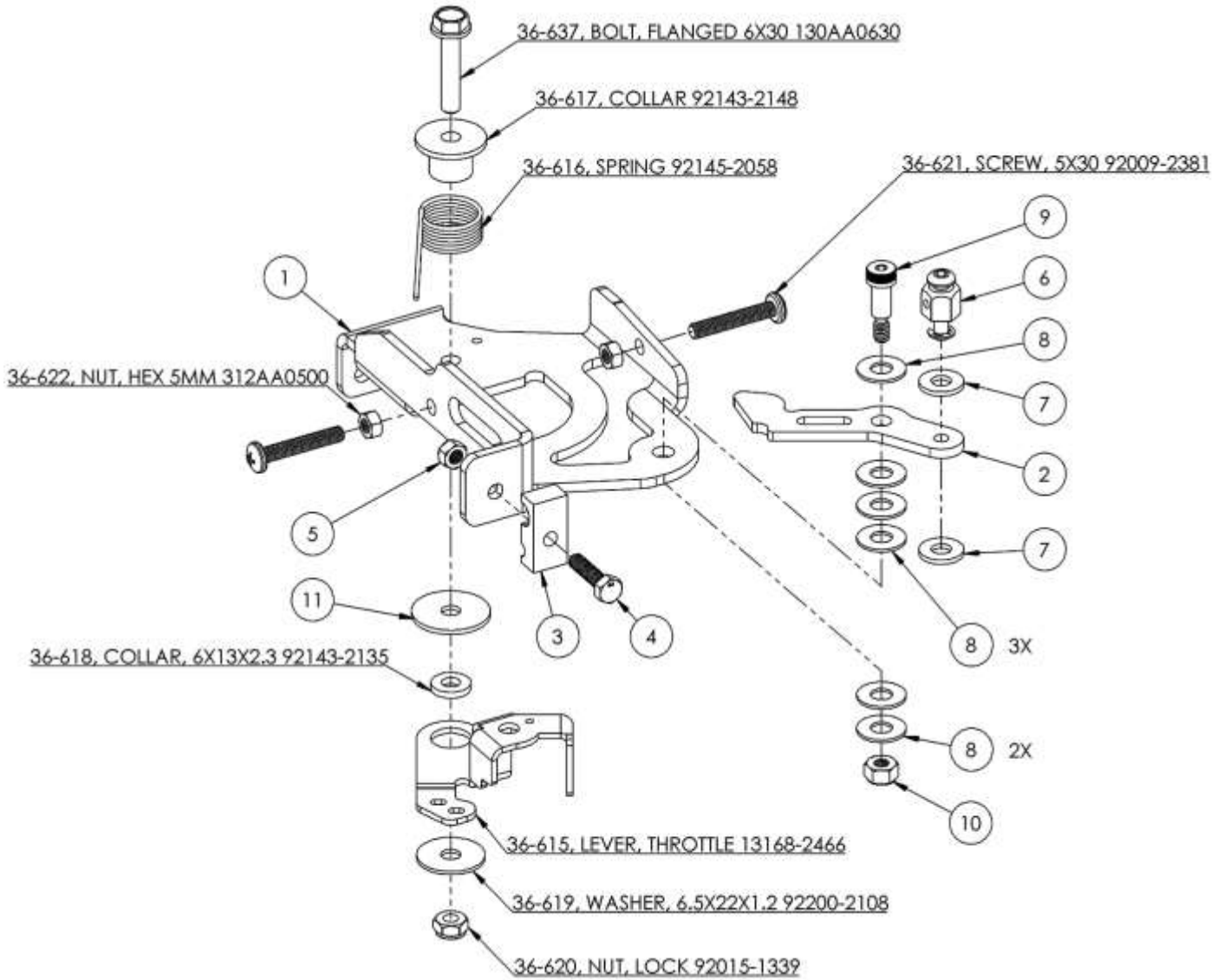

1	11	12-069	WASHER, FENDER 1/4 X 1.0 ZP
1	10	11-022	NUT, 10-24 NYLOK SS
1	9	10-429	SCREW, SHOULDER 1/4X1/2X10-24 SS
6	8	12-002	WASHER, FLAT 1/4 SS ANC
2	7	12-011	WASHER, FLAT #12 SAE
1	6	15-085	WIRE PIVOT, 3/16 SHANK X 1/4 GRIP
1	5	11-078	NUT, M5-0.8 NYLOCK ZP
1	4	10-243	SCREW, MACH M5-0.8 X 20MM Z HXHD G8.8
1	3	66-122	RETAINER, CABLE
1	2	58-1008	LEVER, THROTTLE CONTROL
1	1	58-1007	BRKT, THROTTLE CONTROL
QTY	ITEM	PART NO.	DESCRIPTION

SECTION FIVE: PARTS LISTING AND REFERENCE
69-955, VACUUM PUMP ASSEMBLY

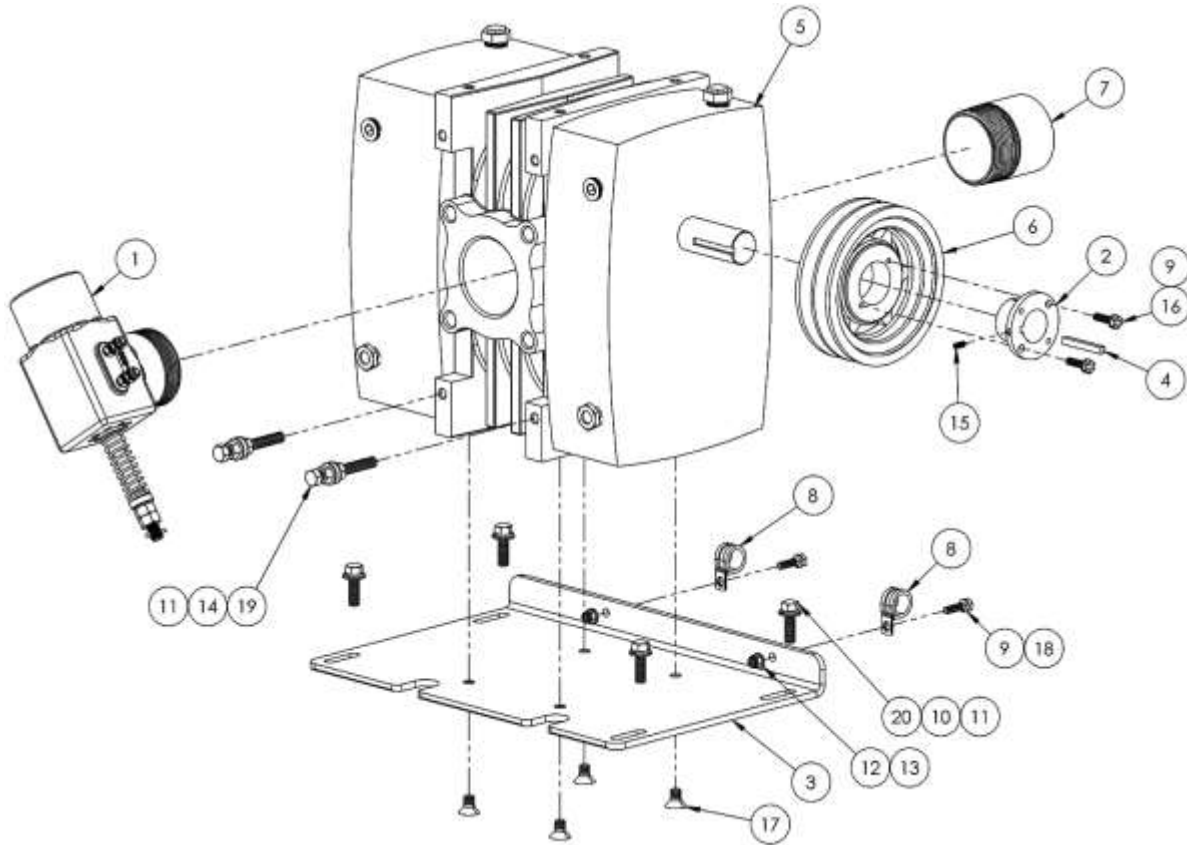

4	20	10-004	SCREW, MACH 3/8-16 X 1-1/4 HEXHD
2	19	10-010	SCREW, MACH 3/8-16 X 4 ALLTHRD
2	18	10-026	SCREW, MACH 1/4-20 X 1 HXHD
4	17	10-166	SCREW, 3/8-16 X 5/8 SS FHSCS
2	16	10-175	SCREW, MACH 1/4-20 X 1 HXHD YZB
1	15	10-356	SCREW, SET 10-32 X .5 CP SOCHD BLK
4	14	11-006	NUT, 3/8-16 ZINC
2	13	11-013	NUT, 1/4-20 NYLOK SS
2	12	12-011	WASHER, FLAT #12 SAE
8	11	12-013	WASHER, FLAT 3/8 USS
4	10	12-014	LKWSR, 3/8 ZINC
4	9	12-015	LKWSR, 1/4 ZINC
2	8	14-004	CLAMP,WIRE CUSHION 3/4 ID X 1/4 BOLT
1	7	21-607	NIPPLE, TOE 2-1/2 NPT X 3 IN ALUM
1	6	38-049	PULLEY, BROWNING 2BK62H
1	5	46-055	VACUUM PUMP, GD TI-406
1	4	55-286	MACHINE KEY, 1/4 X 3/16 X 2.0 LG SQ END 1018 CRS
1	3	58-1000	PLT, BLOWER MOUNT
1	2	66-544	HUB, H X 1-1/4 W/SET SCREW
1	1	69-432	ASSEMBLY, VACUUM BRAKE, 3L
QTY	ITEM	PART NO.	DESCRIPTION

SECTION FIVE: PARTS LISTING AND REFERENCE
69-432, VACUUM RELIEF VALVE ASSEMBLY

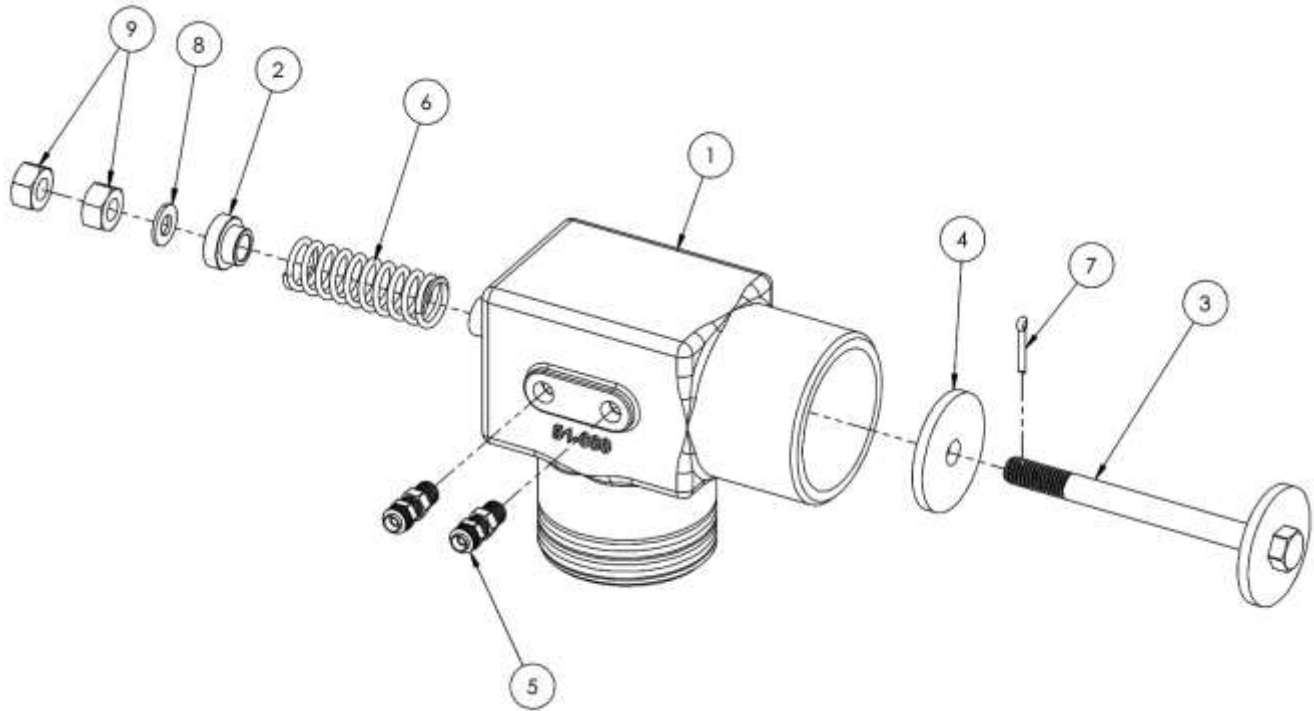

2	9	11-012	NUT, 7/16-14 ZP
1	8	12-017	WASHER, FLAT 5/16 SAE ZINC
1	7	14-032	PIN, COTTER 7/64 X 3/4 SS
1	6	15-002	SPRING, VAC RELIEF VALVE
2	5	21-028	CONN, 1/8 P X 1/4 POLY
1	4	41-010	DIAPHRAGM, VAC RELIEF 3L&4M
1	3	61-1142	WELDMENT, VACUUM STEM
1	2	66-501	BUSHING, SMALL SPRING RETAINER
1	1	66-576	VAC BRAKE, MACHINED 3L
QTY	ITEM	PART NO.	DESCRIPTION

SECTION FIVE: PARTS LISTING AND REFERENCE
69-917, PRESSURE PUMP ASSEMBLY

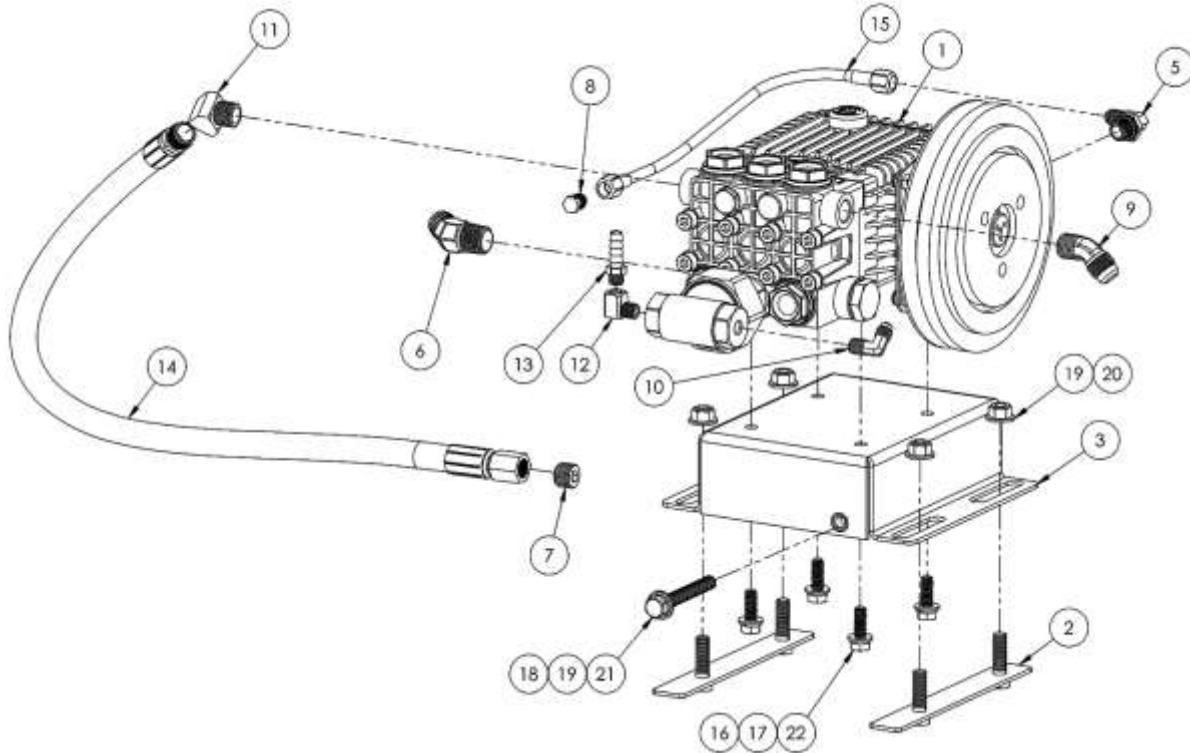

4	22	10-013	SCREW, MACH M8-1.25 X .25 HEXHD G8.8 ZP
1	21	10-057	BOLT, TAP 3/8-16 X 3 GR 5
4	20	11-019	NUT, 3/8-16 NYLOK
5	19	12-013	WASHER, FLAT 3/8 USS
1	18	12-014	LKWSR, 3/8 ZINC
4	17	12-016	LKWSR, 5/16 ZINC
4	16	12-017	WASHER, FLAT 5/16 SAE ZINC
1	15	18-215-09	HOSE ASSY, 3/16 ID X 04 FJIC X 04 FJIC X 16.5L
1	14	18-352	HOSE, PULSE 3/8 X 26 3/8 MNPT X 3/8 FNPT ZP
1	13	21-007	FTTG, BRB 1/8 P X 5/16 H BR
1	12	21-038	ELL, STREET 1/8 IN BRASS
1	11	21-043	ELL, STREET 3/8 IN 45 DEG BRASS
1	10	21-054	ELL, 1-8P X 1/4 T BRASS
1	9	21-059	ELL, 3/8 NPT X 1/2 JIC 45 DEG BRASS
1	8	21-096	PLUG, 1/4 JIC BRASS
1	7	21-146	PLUG, 3/8 NPT BRASS
1	6	21-431	ELL, 1/2P X 3/4H 45 DEG BRASS
1	5	21-599	ELL, 1/4 BSPP X 1/4 JIC STEEL
10 IN	4	32-025	LOOM, HI HEAT .250 DIA. BLACK
1	3	61-1498	WELDMENT, PRESS PUMP BRKT
2	2	61-1505	WELDMENT, WTR PUMP BOLT PLT
1	1	68-179	ASSY, PRESSURE PUMP
QTY	ITEM	PART NO.	DESCRIPTION

SECTION FIVE: PARTS LISTING AND REFERENCE
68-179, PRESSURE PUMP BREAKDOWN

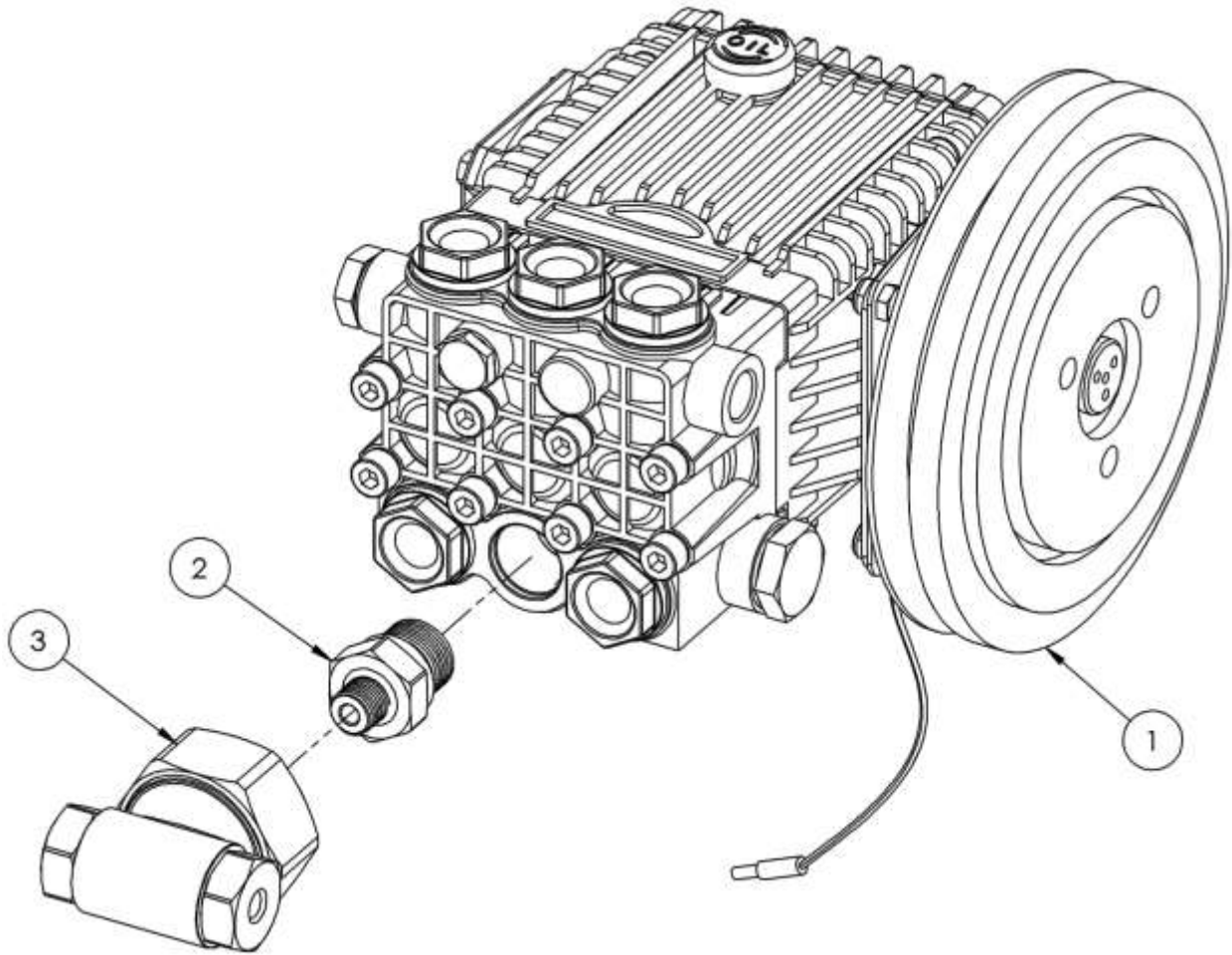

1	3	46-056	PUMP, CHEMICAL GENERAL 100906
1	2	36-412	ADAPTER, 63(TX) PUMP SERIES
1	1	46-063	PUMP, WATER GENERAL HTX1813S
QTY	ITEM	PART NO.	DESCRIPTION

AVAILABLE FOR SERVICE:

36-463, SEAL KIT, HTS PUMP SERIES (20MM PLUNGER SEAL REPLACEMENT KIT)

36-467, VALVE KIT, HTS PUMP SERIES (HIGH TEMPERATURE VALVE REPLACEMENT KIT)

SECTION FIVE: PARTS LISTING AND REFERENCE
46-056, PUMP, CHEMICAL GENERAL 100906

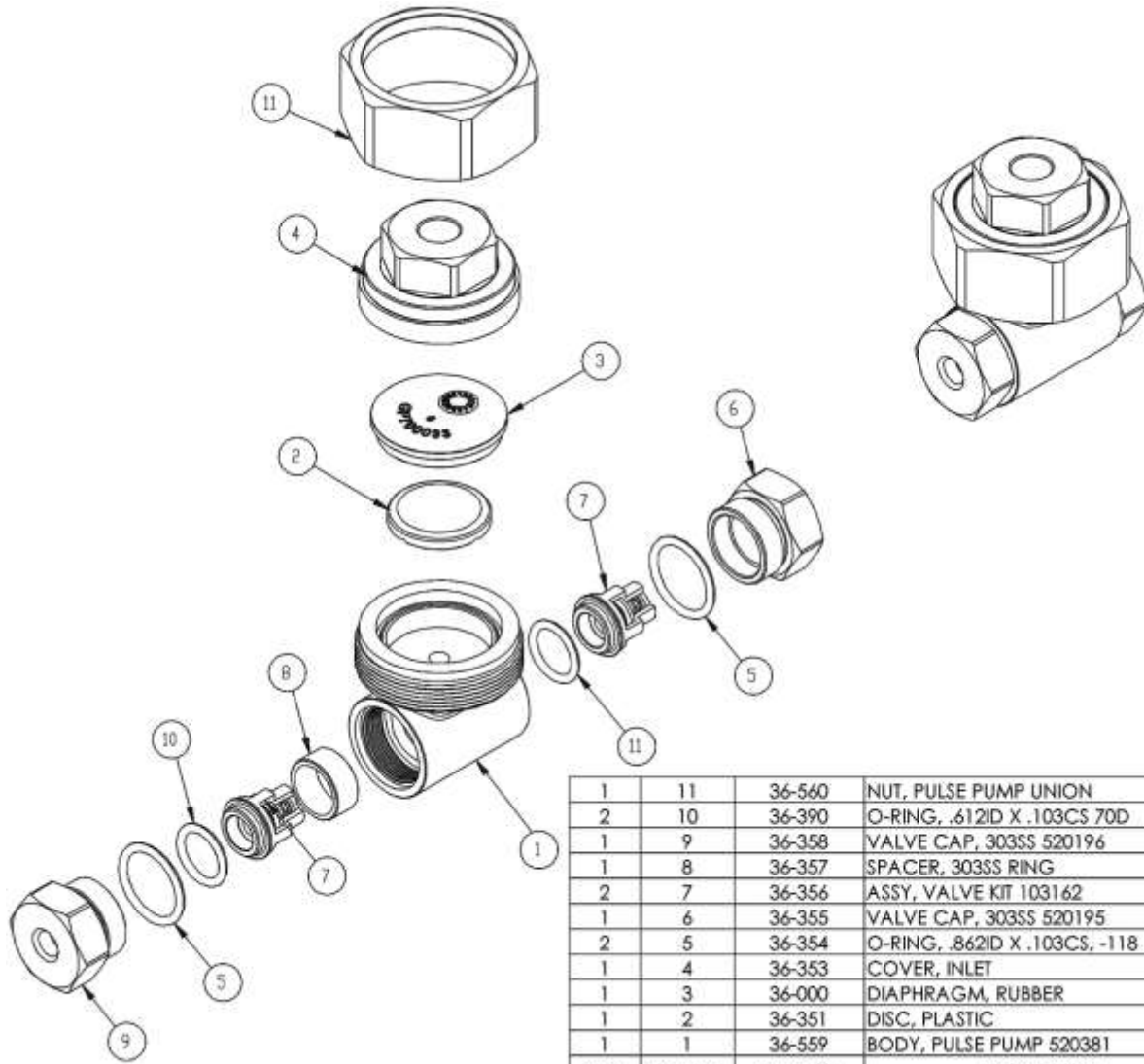

1	11	36-560	NUT, PULSE PUMP UNION
2	10	36-390	O-RING, .612ID X .103CS 70D
1	9	36-358	VALVE CAP, 303SS 520196
1	8	36-357	SPACER, 303SS RING
2	7	36-356	ASSY, VALVE KIT 103162
1	6	36-355	VALVE CAP, 303SS 520195
2	5	36-354	O-RING, .862ID X .103CS, -118
1	4	36-353	COVER, INLET
1	3	36-000	DIAPHRAGM, RUBBER
1	2	36-351	DISC, PLASTIC
1	1	36-559	BODY, PULSE PUMP 520381
QTY	ITEM NO.	PART NO.	DESCRIPTION

SECTION FIVE: PARTS LISTING AND REFERENCE
69-951, HEAT EXCHANGER ASSEMBLY

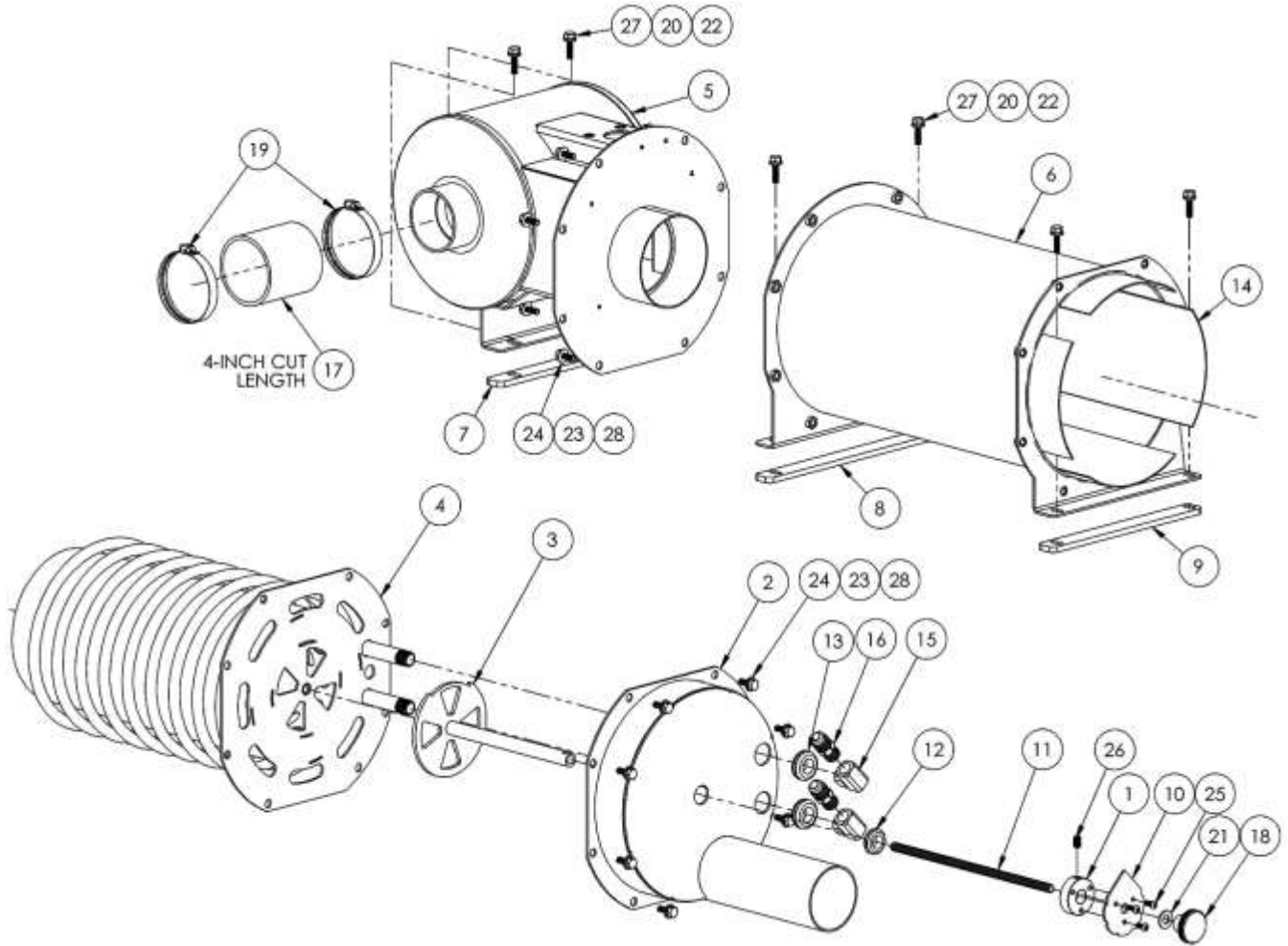

SECTION FIVE: PARTS LISTING AND REFERENCE
69-951, HEAT EXCHANGER ASSEMBLY BOM TABLE

16	28	10-020	SCREW, MACH 1/4-20 X 3/4 HXHD SS
6	27	10-026	SCREW, MACH 1/4-20 X 1 HXHD
1	26	10-051	SCREW, SET 5/16-18 X 1/2
3	25	10-421	SCREW, MACH 10-32 X 1/2 BHSCS ZP
16	24	12-002	WASHER, FLAT 1/4 SS ANC
16	23	12-003	LKWSR, 1/4 IN SS
6	22	12-011	WASHER, FLAT #12 SAE
1	21	12-013	WASHER, FLAT 3/8 USS
6	20	12-015	LKWSR, 1/4 ZINC
2	19	14-081	CLAMP, HOSE #44 SS
1	18	15-087	KNOB, STEEL ROUND KNURLED RIM BO
4.00 IN	17	16-122	HOSE, 2.88 IN ID X 3FT SILICONE 550F
2	16	21-057	CONN, 3/8 NPT X 1/2 JIC BRASS
2	15	21-152	ELL, 3/8 FNPT X 3/8 FNPT BRASS
4	14	41-092	GASKET, 5-13/16 X 17 X .062 SILICONE SHT W/PSA
2	13	41-206	GROMMET, 1.31 OD X .69 ID X .12 PNL SILICONE
1	12	41-218	GROMMET, 1.13 OD X .63 ID X .12 PNL SILICONE
1	11	57-008-01	ALL THREAD, 3/8-16 X 10 IN LG PLAIN GRD A
1	10	58-1020	PLT, EXHAUST OUTLET INDICATOR
1	9	58-1022	SPACER, HEAT EXCHANGER FRONT
1	8	58-1023	SPACER, HEAT EXCHANGER MID
1	7	58-1024	SPACER, HEAT EXCHANGER REAR
1	6	61-1480	WELDMENT, HOUSING
1	5	61-1481	WELDMENT, MUFFLER
1	4	61-1486	ASSY, FINNED TUBE COIL
1	3	61-1593	WMT, EXHAUST BYPASS
1	2	61-1594	WMT, EXHAUST OUTLET COVER
1	1	66-612	MOUNT, EXHAUST OUTLET INDICATOR
QTY	ITEM	PART NO.	DESCRIPTION

SECTION FIVE: PARTS LISTING AND REFERENCE
69-973, COOLANT HEAT EXCHANGER

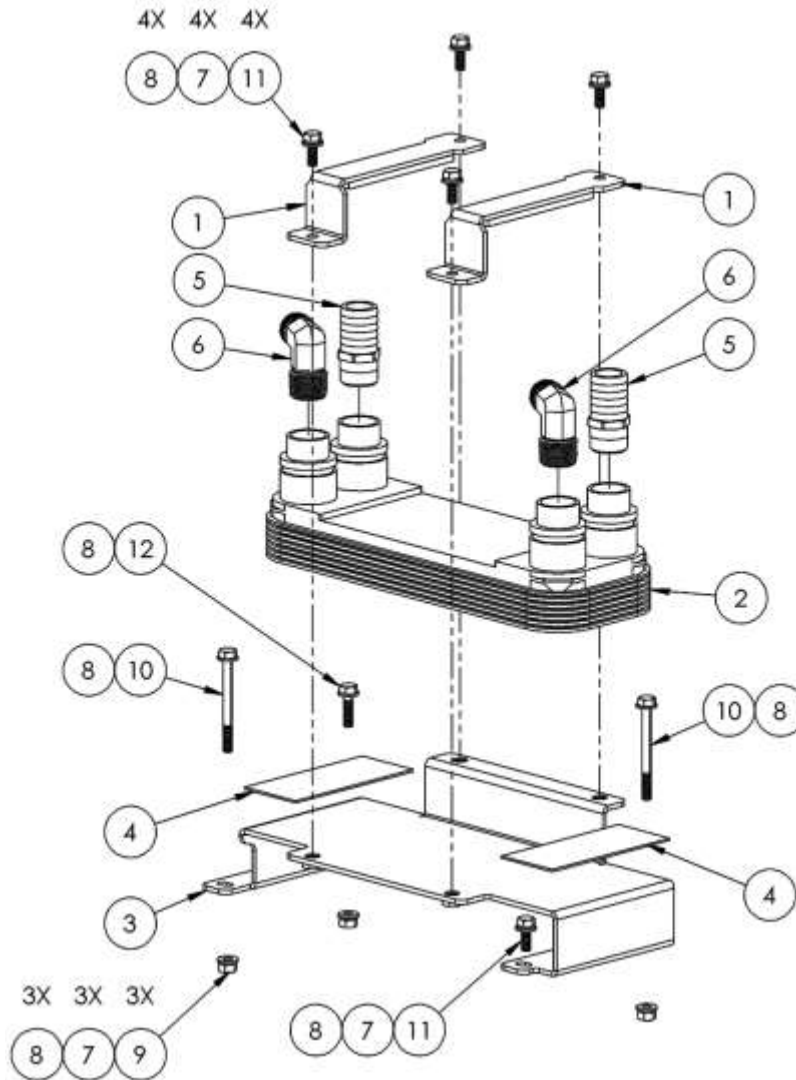

1	12	10-011	SCREW, MACH 1/4-20 X 1 HXHD SS
5	11	10-025	SCREW, MACH 1/4-20 X 3/4 HXHD GRD5
2	10	10-028	SCREW, MACH 1/4-20 X 2-3/4 HXHD
3	9	11-004	NUT, 1/4-20 ZINC
11	8	12-011	WASHER, FLAT #12 SAE
8	7	12-015	LKWSR, 1/4 ZINC
2	6	21-074	ELL, 3/4 P X 1/2 T BRASS
2	5	21-381	FTG, 3/4P X 1H BRASS
2	4	41-212	GASKET, HEAT EXCHANGER BRKT
1	3	61-1421	WELDMENT, HEAT EXCH BASE
1	2	63-244	HEAT EXCHANGER, PLATE
2	1	69-968	ASSY, PLT HEAT EXCH CLAMP
QTY	ITEM	PART NO.	DESCRIPTION

SECTION FIVE: PARTS LISTING AND REFERENCE
69-980, WATER BOX ASSEMBLY

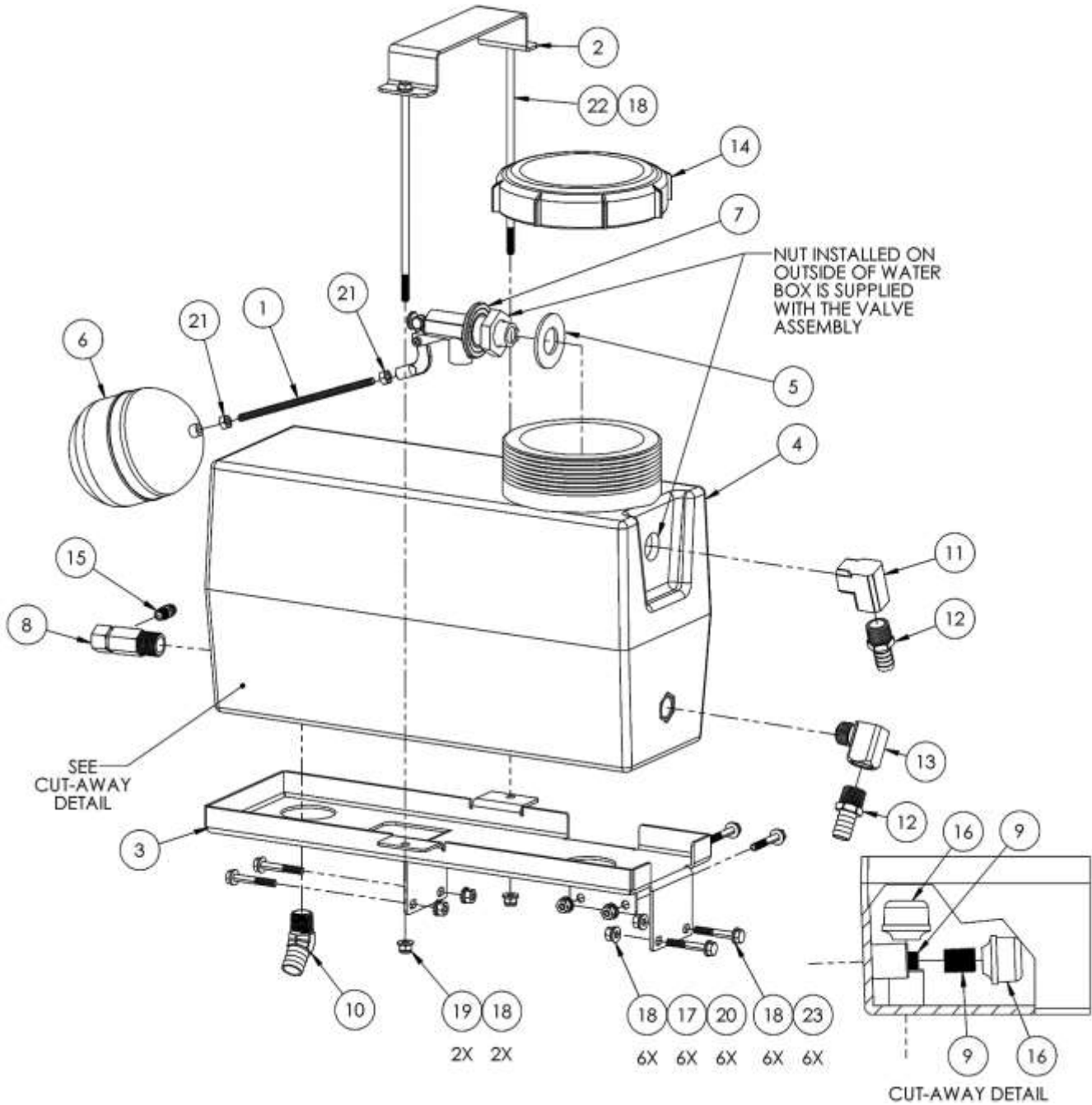

SECTION FIVE: PARTS LISTING AND REFERENCE
69-980, WATER BOX ASSEMBLY

6	23	10-170	SCREW, MACH, 1/4-20 X 1-3/4 HH G5
2	22	10-416	SCREW, MACH 1/4-20 X 8 HXHD ZP
2	21	11-001	NUT, 1/4-20 SS
6	20	11-004	NUT, 1/4-20 ZINC
2	19	11-013	NUT, 1/4-20 NYLOK SS
16	18	12-011	WASHER, FLAT #12 SAE
6	17	12-015	LKWSR, 1/4 ZINC
2	16	20-014	STRAINER, SUC END1/2FP 40 MESH
1	15	21-001	CONN, 1/8 P X 1/4 T BR
1	14	21-025	CAP, 5 IN, BLACK
1	13	21-034	ELL, STREET 1/2 NPT BRASS
2	12	21-109	FTTG, 1/2 NPT X 5/8 BARB BRASS
1	11	21-127	ELL, 1/2 NPT BRASS
1	10	21-431	ELL, 1/2P X 3/4H 45 DEG BRASS
2	9	21-515	NIPPLE, 1/2 NPT CLOSE BRASS
1	8	23-033	VALVE, 165 DEG THERMAL CAT 7145
1	7	23-134	VALVE, FLOAT 1/4 NPT LEGEND
1	6	28-001	BALL, FLOAT
1	5	41-214	GASKET, 1.0 ID X 2.0 OD X 3MM NEOPRENE
1	4	51-118	MOLDING, WATER BOX LEGEND
1	3	58-966	BRKT, WTR BOX MTG
1	2	58-967	BRKT, WTR BOX HOLDDOWN
1	1	64-072	ROD, FLOAT 6 IN SS
QTY	ITEM	PART NO.	DESCRIPTION

SECTION FIVE: PARTS LISTING AND REFERENCE
69-958, PRESSURE REGULATOR ASSEMBLY

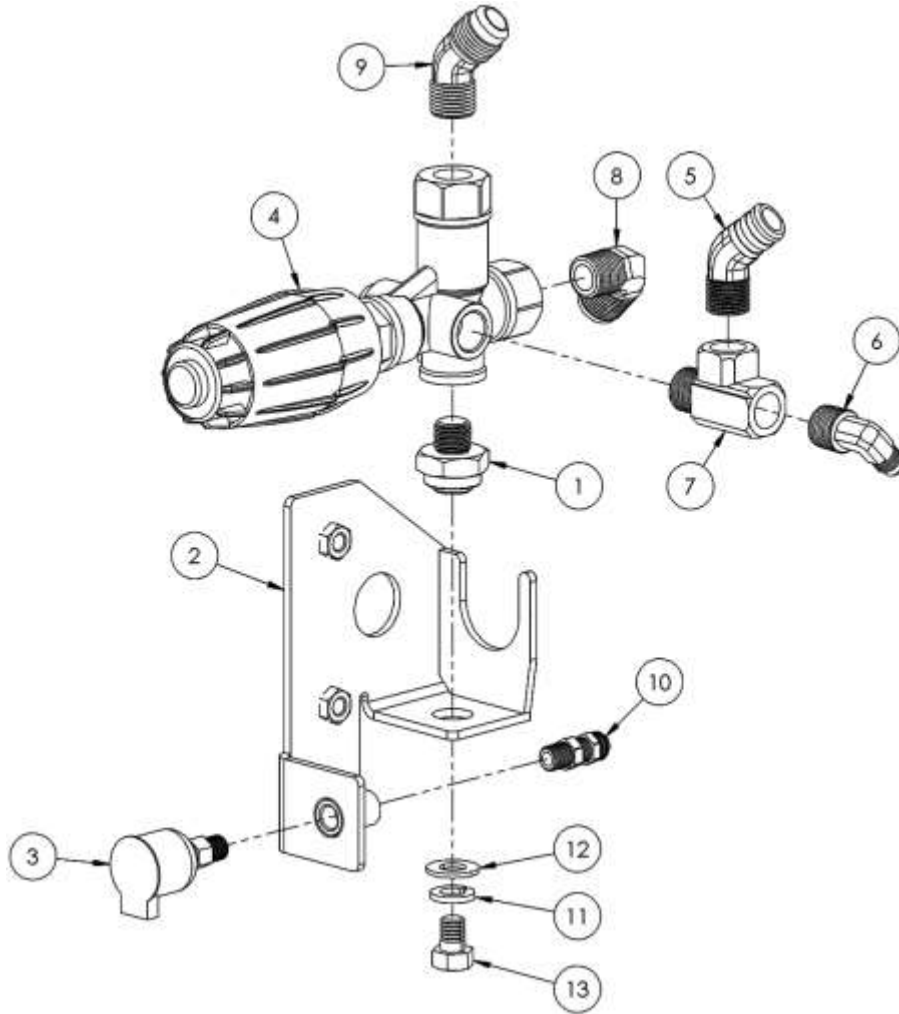

1	13	10-157	SCREW, MACH 3/8-16 X 1/2 HH ZP
1	12	12-013	WASHER, FLAT 3/8 USS
1	11	12-014	LKWSR, 3/8 ZINC
1	10	21-028	CONN, 1/8 P X 1/4 POLY
1	9	21-059	ELL, 3/8 NPT X 1/2 JIC 45 DEG BRASS
1	8	21-061	ELL, 3/8 P X 1/2 T BRASS
1	7	21-062	TEE, 3/8 FNPT X NPT X FNPT BRASS
1	6	21-063	ELL, 3/8 P X 1/4 T BRASS
1	5	21-413	FTG, BARB 45 DEG 3/8P X 5/8H
1	4	23-143	UNLOADER, VRT3 1500 PSI
1	3	28-000	CUP, OILFILL, 1/8 NPT
1	2	61-1585	WMT, PRESSURE REG BRKT
1	1	66-340	FITTING, 3/8 NPT M X 3/8-16 F STANDOFF
QTY	ITEM	PART NO.	DESCRIPTION

SECTION FIVE: PARTS LISTING AND REFERENCE
69-971, SOLUTION MANIFOLD ASSEMBLY

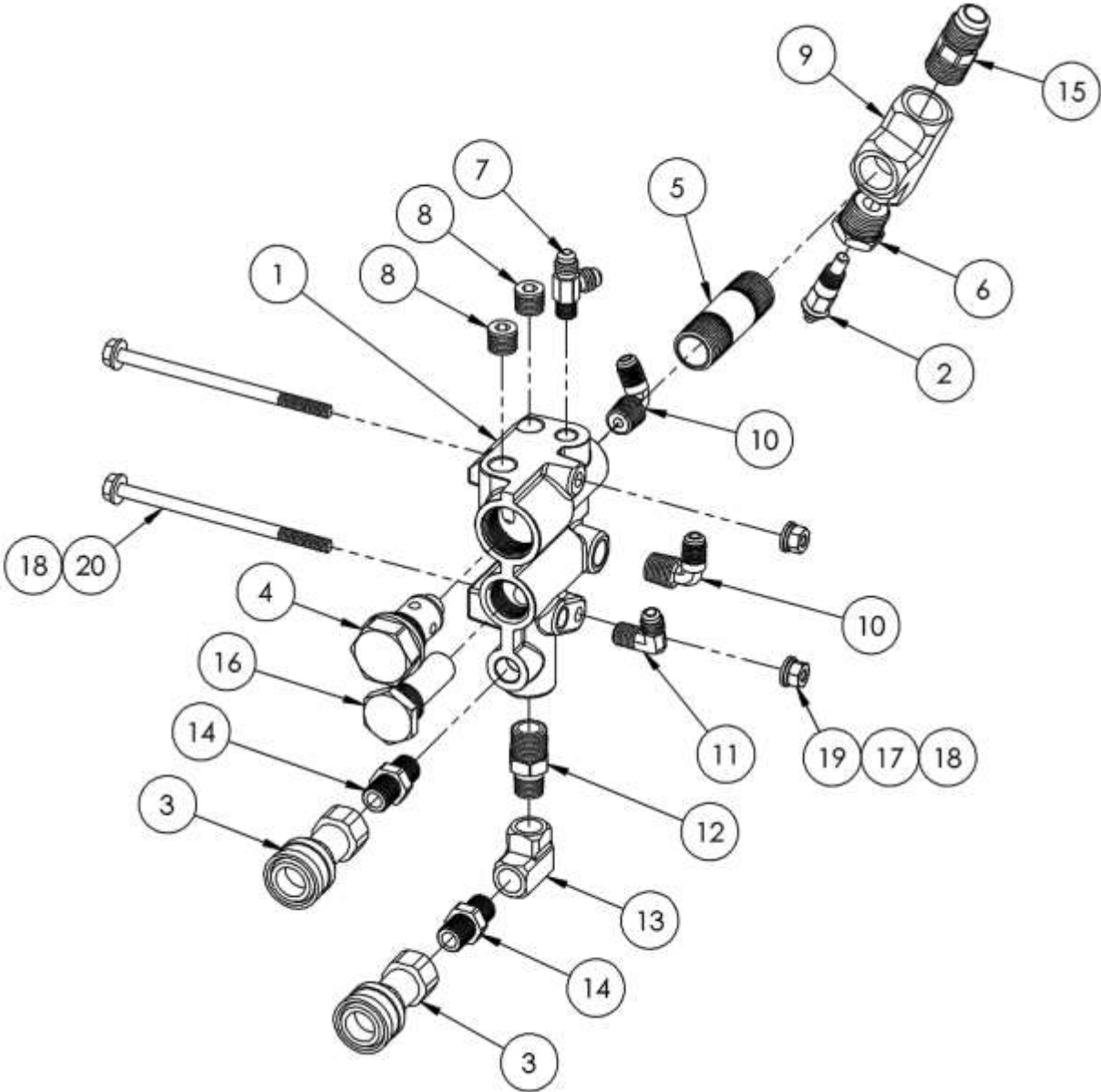

SECTION FIVE: PARTS LISTING AND REFERENCE
69-971, SOLUTION MANIFOLD ASSEMBLY BOM TABLE

2	20	10-160	BOLT, 1/4-20 X 4 1/2 HH ZP
2	19	11-004	NUT, 1/4-20 ZINC
4	18	12-011	WASHER, FLAT #12 SAE
2	17	12-015	LKWSR, 1/4 ZINC
1	16	20-018	SCREEN, CHECK VALVE MANIFOLD
1	15	21-012	CONN, 1/2 NPT X 1/2 T BRASS
2	14	21-026	NIP, 1/4 HEX BRASS
1	13	21-037	ELL, 1/4 IN. BRASS
1	12	21-052	NIP, 3-8 X 1-4 HEX BRASS
1	11	21-054	ELL, 1-8P X 1/4 T BRASS
2	10	21-064	ELL, 1/4 P X 1/4 T BRASS
1	9	21-110	TEE, 1/2 NPT BRASS
2	8	21-264	PLUG, 1/4 NPT BRASS
1	7	21-336	TEE, RUN 1/8 NPT X 1/4 JIC X 1/4 JIC BRASS
1	6	21-373	BUSHING, 1/2 NPT X 1/8 FNPT BRASS
1	5	21-374	NIPPLE, 1/2 NPT X 2-1/2L 304SS
1	4	23-063	ASSY, CHECK VALVE
2	3	25-001	DSC, 1/4F X 1/4FP BRASS
1	2	34-000	SENSOR, TEMP, 140-320 DEGREE
1	1	66-205	MANIFOLD BLOCK
QTY	ITEM	PART NO.	DESCRIPTION

SECTION FIVE: PARTS LISTING AND REFERENCE
69-972, BYPASS MANIFOLD ASSEMBLY

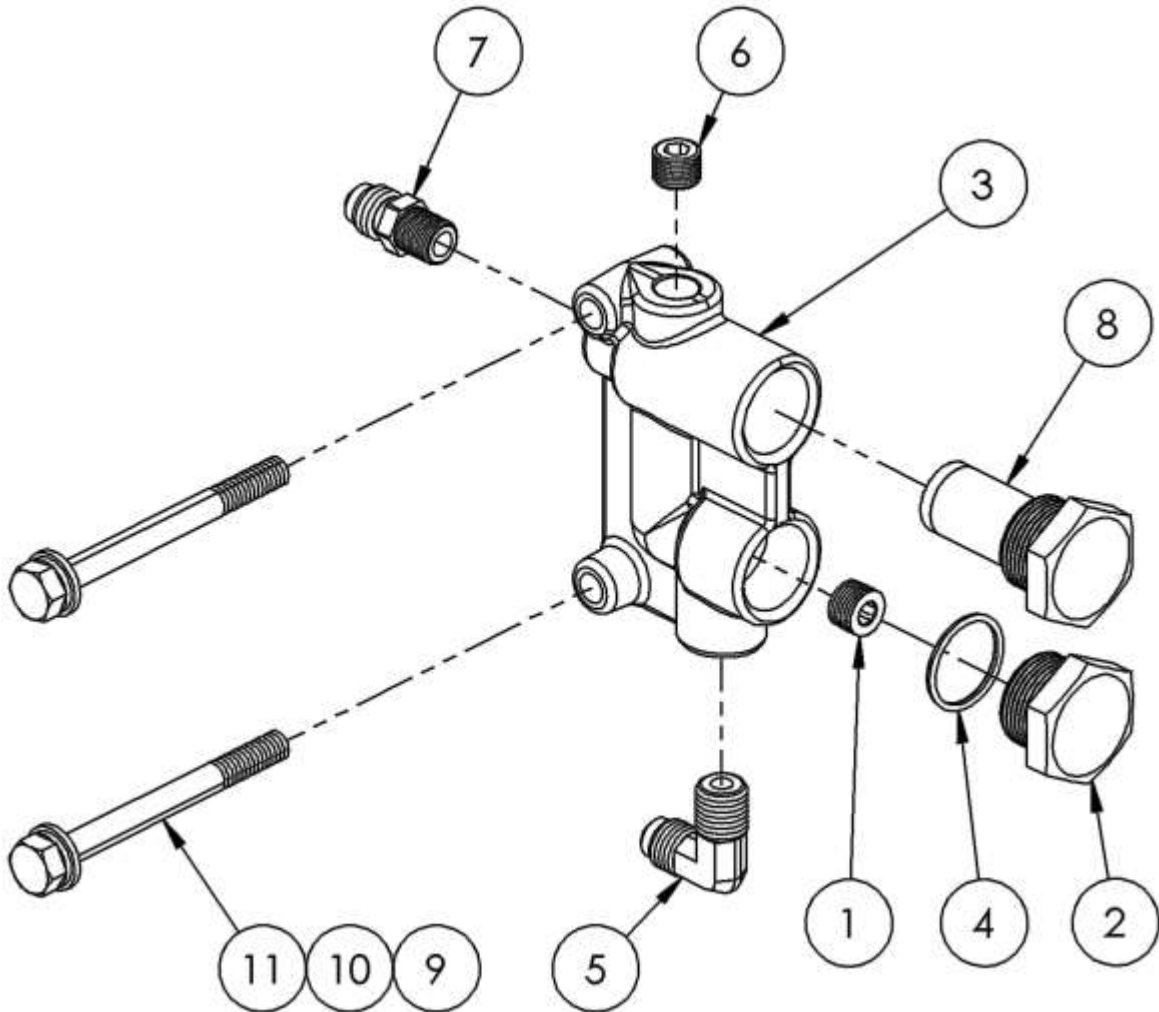

2	11	10-028	SCREW, MACH 1/4-20 X 2-3/4 HXHD
2	10	12-011	WASHER, FLAT #12 SAE
2	9	12-015	LKWSR, 1/4 ZINC
1	8	20-015	SCREEN, BYPASS MANIFOLD
1	7	21-001	CONN, 1/8 P X 1/4 T BR
1	6	21-029	PLUG, 1/8 NPT SOCKET HD BRASS
1	5	21-054	ELL, 1-8P X 1/4 T BRASS
1	4	41-003	ORING, .676 ID .816 OD
1	3	66-011	MANIFOLD, BYPASS
1	2	66-017	CAP, CHECK VALVE
1	1	66-019	ORIFICE, BYPASS, .029 RED
QTY	ITEM	PART NO.	DESCRIPTION

SECTION FIVE: PARTS LISTING AND REFERENCE
69-956, WATER/VACUUM INLET BRACKET ASSEMBLY

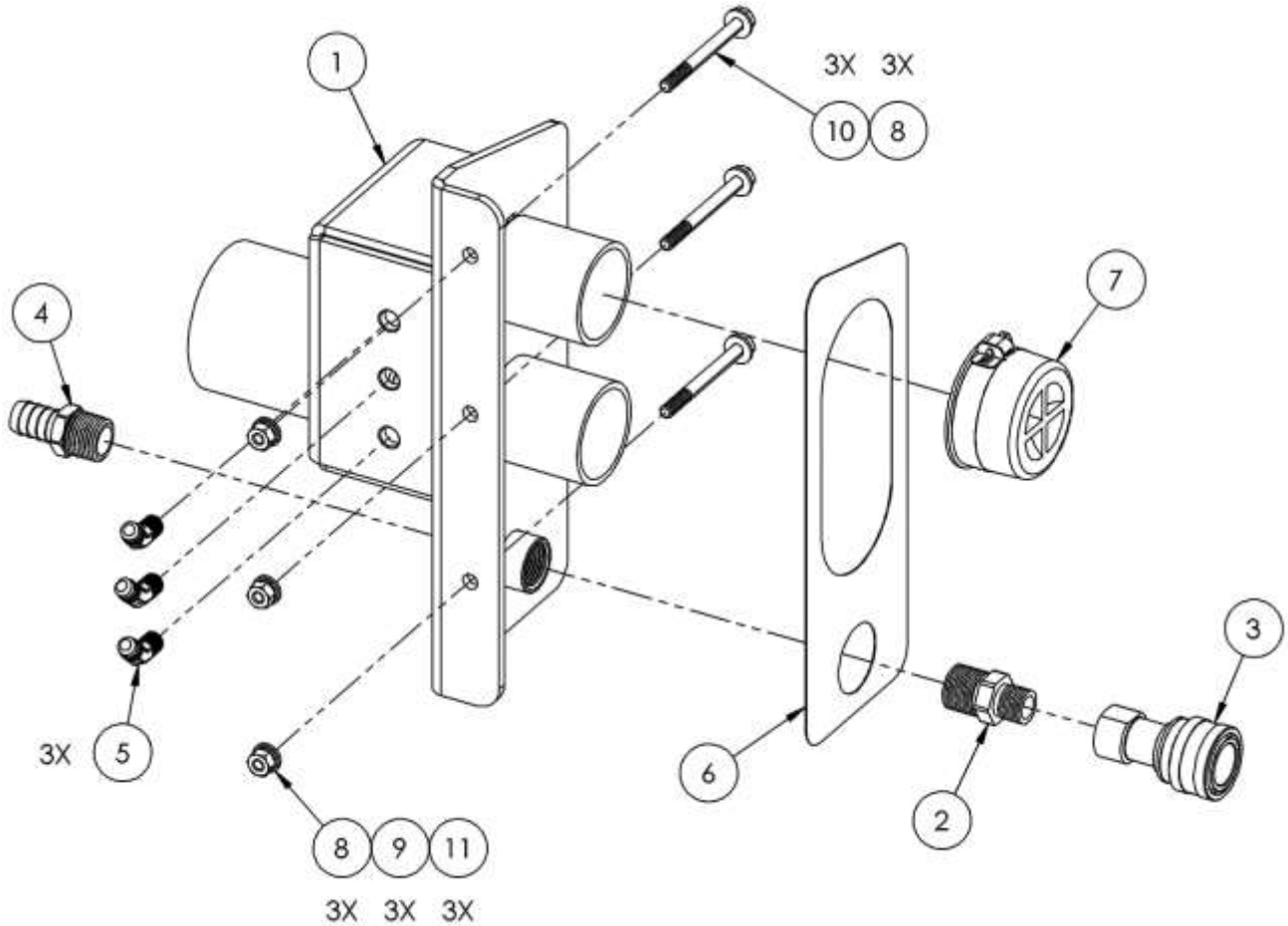

3	11	11-004	NUT, 1/4-20 ZINC
3	10	10-028	SCREW, MACH 1/4-20 X 2-3/4 HXHD
3	9	12-015	LKWSR, 1/4 ZINC
6	8	12-011	WASHER, FLAT #12 SAE
1	7	19-009	CAP, PLUG 2IN RUBBER
1	6	44-331	DECAL, WTR-VAC INLET
3	5	21-055	ELL, 1-8 P X 1/4 T 45 DEG BRASS
1	4	21-109	FTG, 1/2 NPT X 5/8 BARB BRASS
1	3	25-005	QUICK COUPLING, 3/8 F X 3/8 FNPT BRASS
1	2	21-030	NIPPLE, HEX 1/2 NPT X 3/8 NPT BRASS
1	1	61-1578	WMT, WTR-VAC INLET BRKT
QTY	ITEM	PART NO.	DESCRIPTION

SECTION FIVE: PARTS LISTING AND REFERENCE
69-926, 90 GALLON WASTE TANK ASSEMBLY

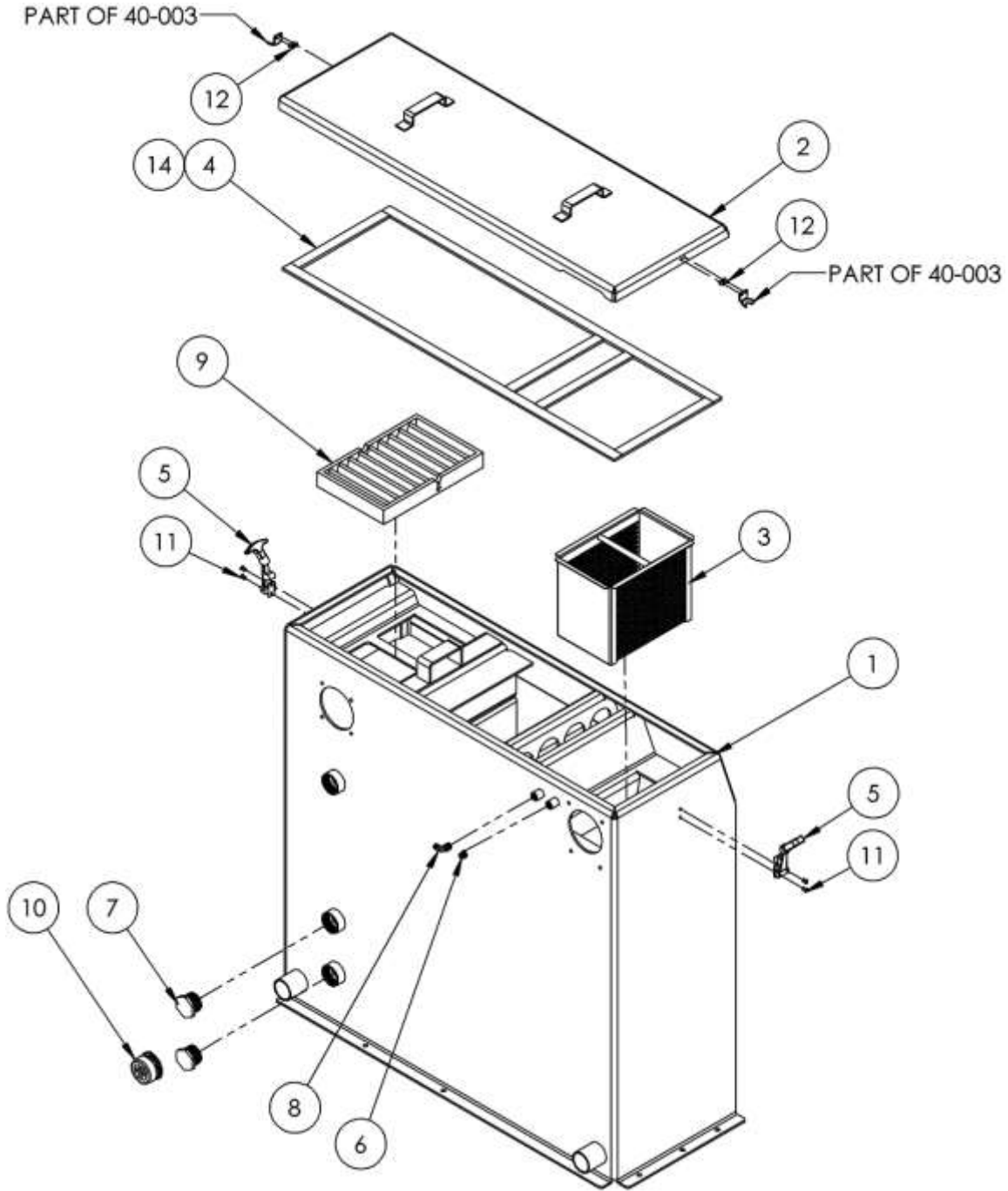

SECTION FIVE: PARTS LISTING AND REFERENCE
69-926, 90 GALLON WASTE TANK ASSEMBLY TABLE

.34	13	13-005	ADHESIVE, GASKET BOSTIK 1100 10.1 OZ TUBE
4	12	14-018	RIVET, SS 3/16 LONG
4	11	14-031	RIVET, SS 3/16 X 1/2 SHORT
1	10	19-009	CAP, PLUG 2IN RUBBER
1	9	20-071	STRAINER, WASTE TANK RECT
1	8	21-064	ELL, 1/4 P X 1/4 T BRASS
2	7	21-097	PLUG, 1-1/4 IN PVC
1	6	21-264	PLUG, 1/4 NPT BRASS
2	5	40-003	LATCH, PRE-FILTER BOX
124 IN	4	41-018	GASKET, SPONGE 1 IN X 45 FT
1	3	61-002	WELDMENT, STRAINER BASKET
1	2	61-1517	WELDMENT, WASTE TANK LID 90 GAL
1	1	61-1518	WELDMENT, WASTE TANK 90 GAL
QTY	ITEM	PART NO.	DESCRIPTION

SECTION FIVE: PARTS LISTING AND REFERENCE
69-925, 120 GALLON WASTE TANK ASSEMBLY

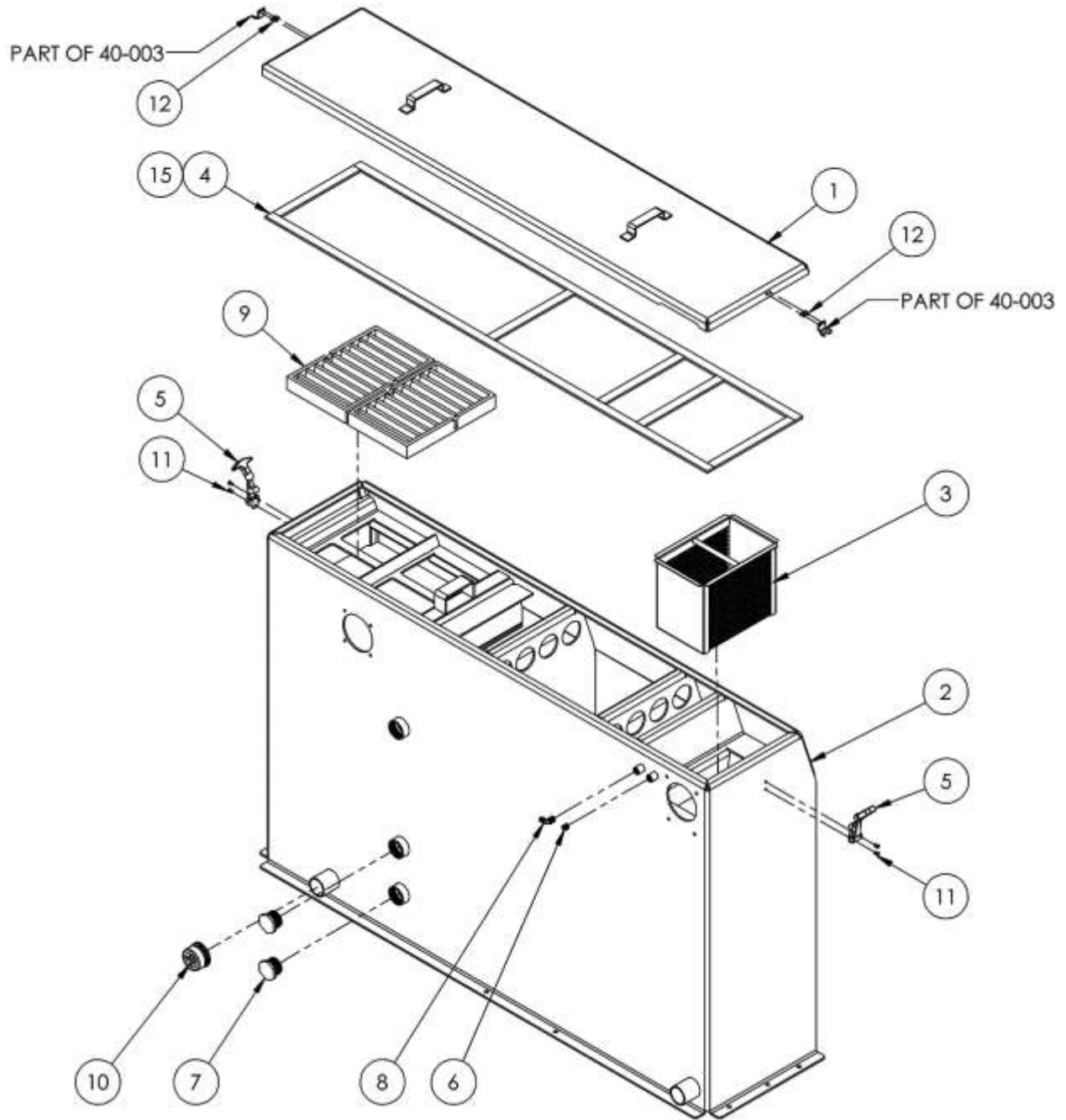

SECTION FIVE: PARTS LISTING AND REFERENCE
69-925 120 GALLON WASTE TANK ASSEMBLY TABLE

.48	13	13-005	ADHESIVE, GASKET BOSTIK 1100 10.1 OZ TUBE
4	12	14-018	RIVET, SS 3/16 LONG
4	11	14-031	RIVET, SS 3/16 X 1/2 SHORT
1	10	19-009	CAP, PLUG 2IN RUBBER
2	9	20-071	STRAINER, WASTE TANK RECT
1	8	21-064	ELL, 1/4 P X 1/4 T BRASS
2	7	21-097	PLUG, 1-1/4 IN PVC
1	6	21-264	PLUG, 1/4 NPT BRASS
2	5	40-003	LATCH, PRE-FILTER BOX
175 IN	4	41-018	GASKET, SPONGE 1 IN X 45 FT
1	3	61-002	WELDMENT, STRAINER BASKET
1	2	61-1519	WELDMENT, WASTE TANK 120 GAL
1	1	61-1520	WELDMENT, WASTE TANK LID 120 GAL
QTY	ITEM	PART NO.	DESCRIPTION

SECTION FIVE: PARTS LISTING AND REFERENCE
48-165 WASTE TANK PORTS KIT

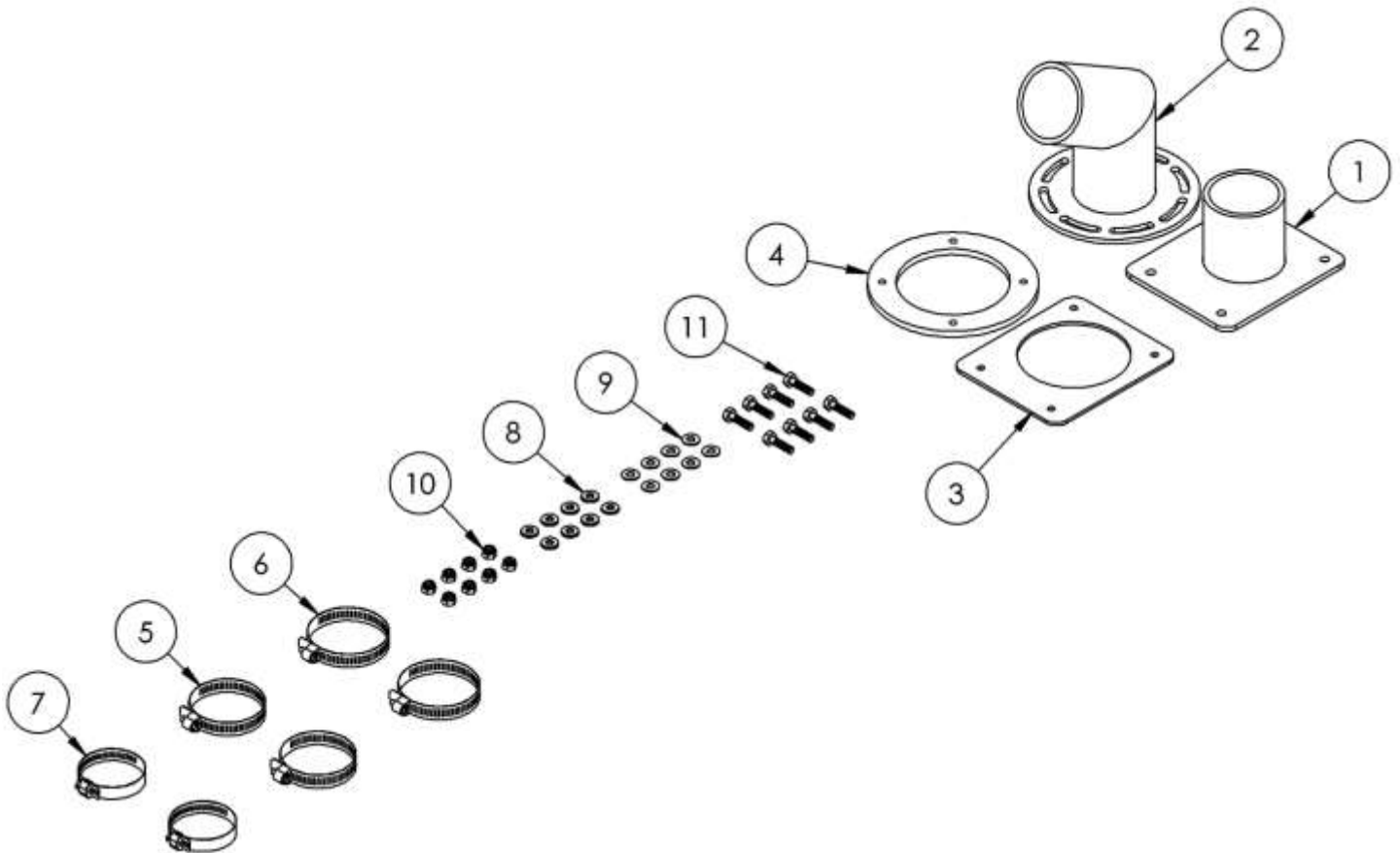

8	11	10-011	SCREW, MACH 1/4-20 X 1 HXHD SS
8	10	11-139	LKNUT, 1/4-20 NYLOK SS
8	9	12-002	WASHER, FLAT 1/4 SS ANC
8	8	12-071	WASHER, SEALING .27 ID X .625 OD
2	7	14-010	CLAMP, HOSE #32
2	6	14-024	CLAMP, HOSE #48 SS
2	5	14-066	CLAMP, HOSE #40 SS
1	4	41-207	GASKET, VAC OUTLET
1	3	41-211	GASKET, VAC INLET LG
1	2	61-1508	WELDMENT, 2-7/8 VAC OUTLET
1	1	61-1576	WMT, 2-7/8 VAC INLET
QTY	ITEM	PART NO.	DESCRIPTION

SECTION FIVE: PARTS LISTING AND REFERENCE
48-164 WASTE TANK HOSES KIT

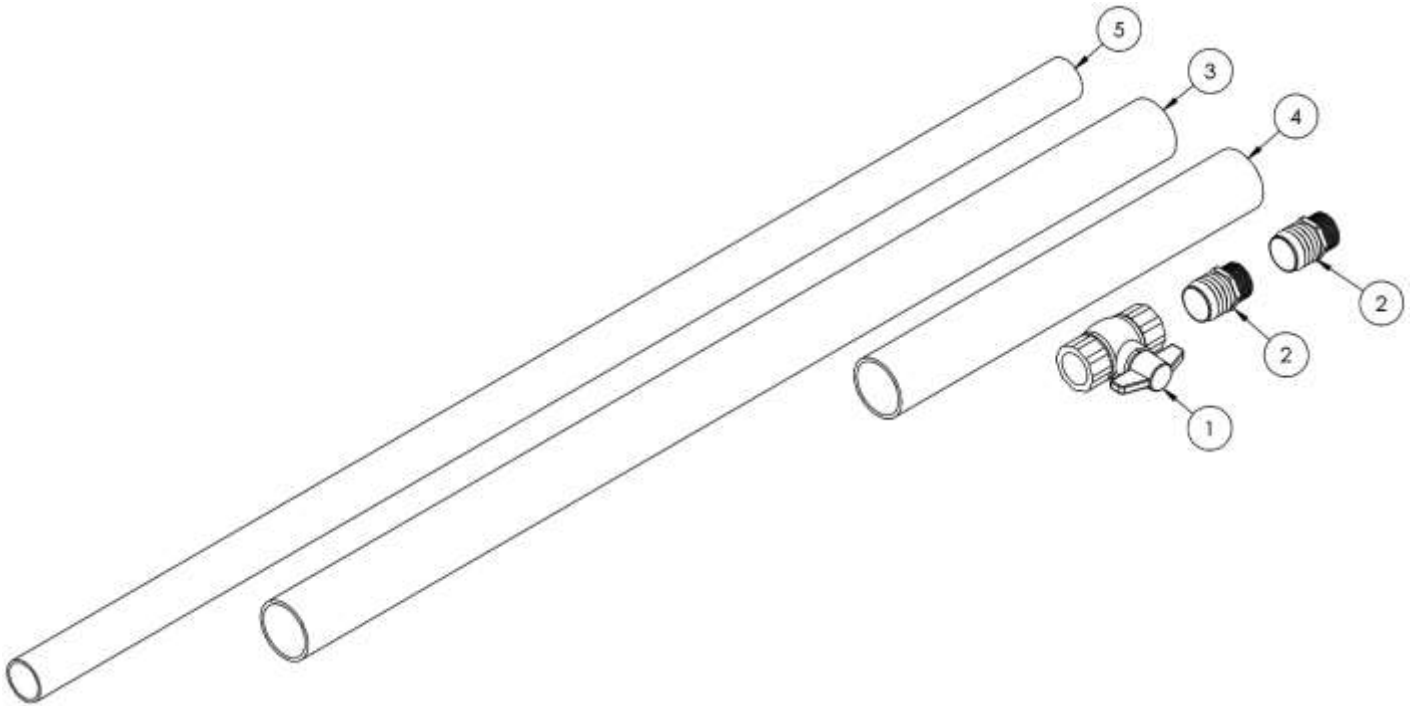

1	5	17-421	HOSE, INT VACUUM 2 IN X 6 FT
1	4	17-554	HOSE, INT VAC 2-7/8 X 25 IN
1	3	17-563	HOSE, INT VAC 2-7/8 X 60 IN
2	2	21-094	FTG, 1-1/2 P X 2H DRAIN
1	1	23-022	VLV, BALL 1-1/2 FP PVC DUMP
QTY	ITEM	PART NO.	DESCRIPTION

SECTION FIVE: PARTS LISTING AND REFERENCE
48-163 FUEL PUMP KIT

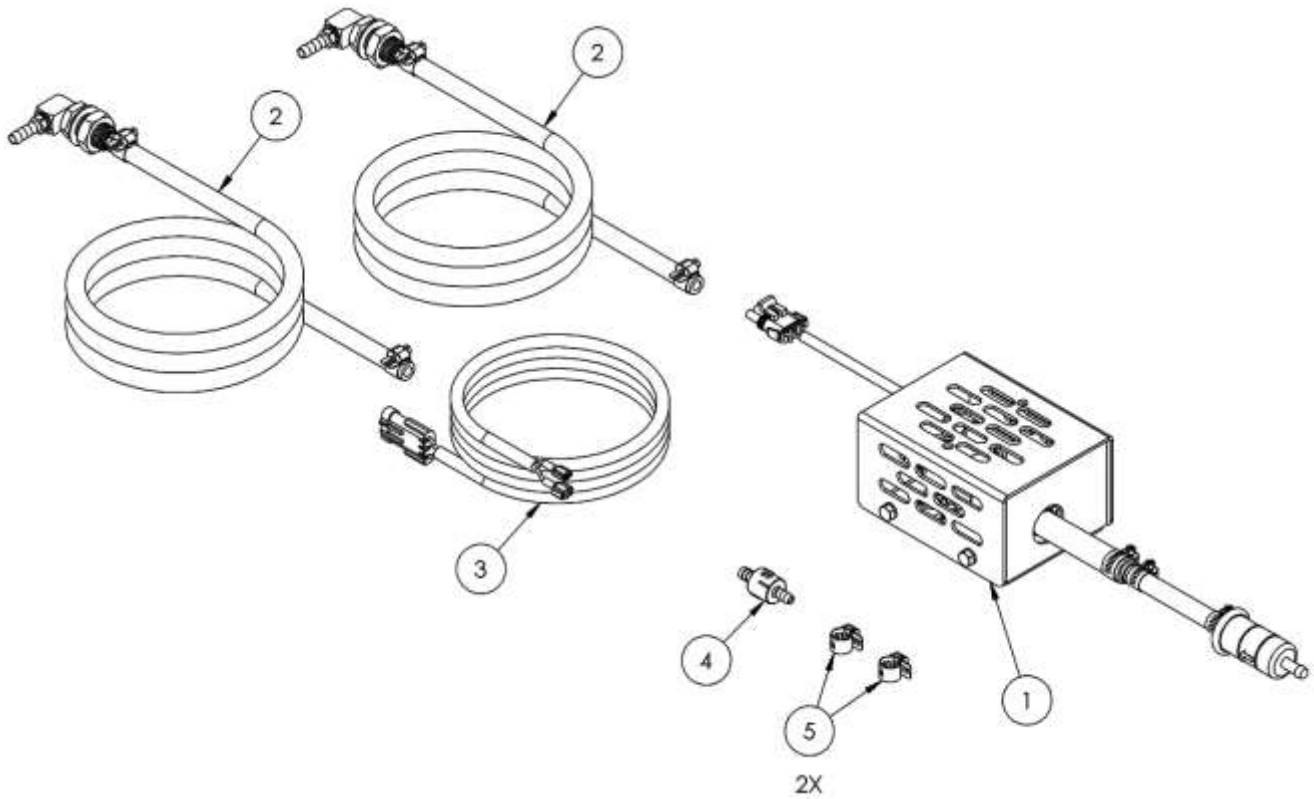

2	5	14-007	CLAMP, HOSE #4
1	4	23-087	CHECK VALVE, FUEL
1	3	47-017	HARNESS, WIRE FUEL PUMP
2	2	68-422	KIT. FUEL LINE BULKHEAD
1	1	68-421	ASSY, FUEL PUMP
QTY	ITEM	PART NO.	DESCRIPTION

SECTION FIVE: PARTS LISTING AND REFERENCE
68-421 FUEL PUMP AND HOUSING ASSEMBLY

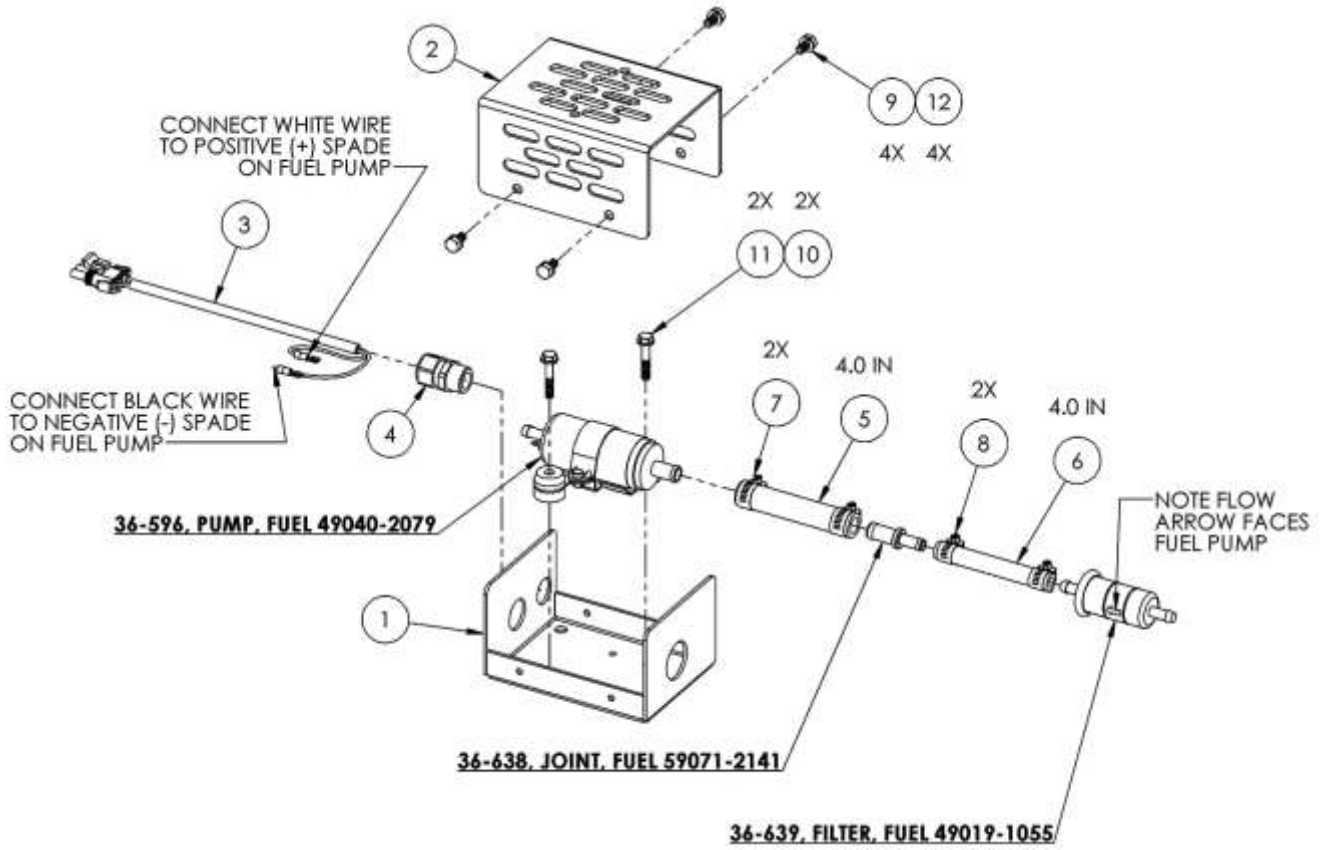

4	12	10-006	SCREW, MACH 1/4-20 X 1/2 HEXHD
2	11	10-247	SCREW, M8-1.0 X 35MM HXHD G8.8 ZP
2	10	12-010	WASHER, FLAT M6 ZP
4	9	12-015	LKWSR, 1/4 ZINC
2	8	14-007	CLAMP, HOSE #4
2	7	14-012	CLAMP, HOSE #8
1	6	16-103	HOSE, FUEL 5/16 30R9 FUEL INJECTION
1	5	16-151	HOSE, FUEL 1/2 IN X 25 FT SAE J30R14T2
1	4	31-047	STRAIN RELIEF #2612
1	3	47-168	HARNESS, FUEL PUMP
1	2	58-034	PNL, BOX TOP FUEL PUMP
1	1	59-210	PNL, BOX BOTTOM FUEL PUMP
QTY	ITEM	PART NO.	DESCRIPTION

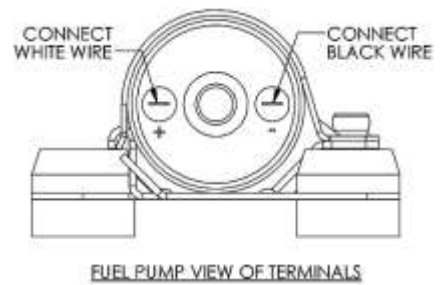

SECTION FIVE: PARTS LISTING AND REFERENCE

68-422, BULKHEAD FUEL FITTING/LINE ASSEMBLY

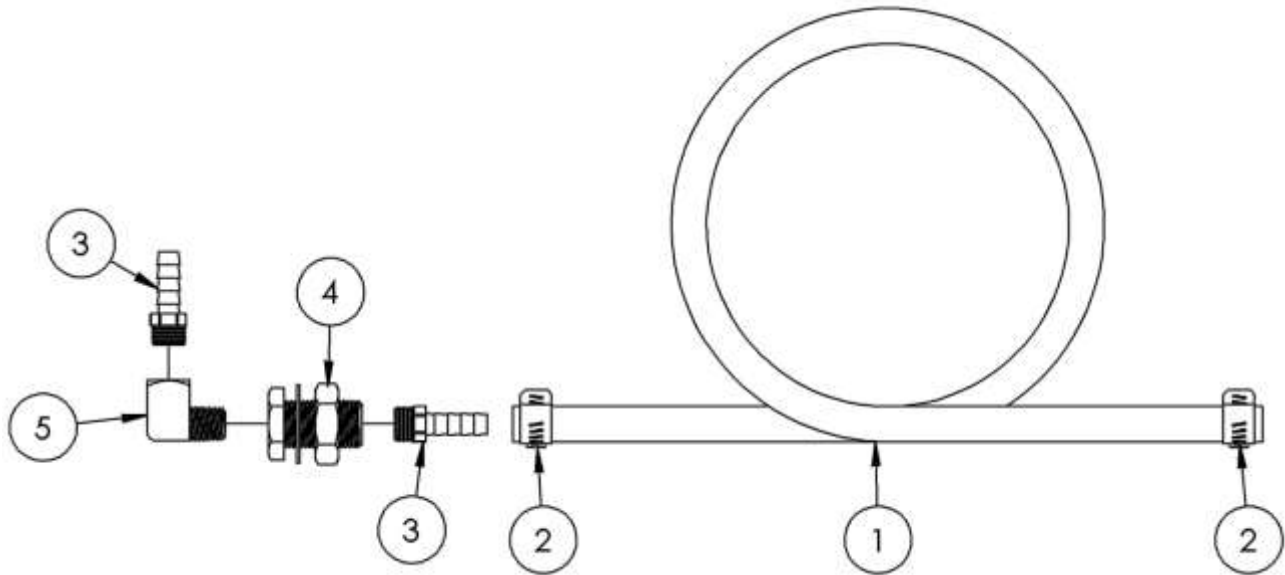

1	5	21-039	FITTING - ELBOW 1/4 IN STREET BRASS
1	4	21-086	FTTG, BULKHEAD 1/4 IN BRASS
2	3	21-006	FITG, BRB 1/4 P X 5/16 H BRASS
2	2	14-007	CLAMP, HOSE #4
1	1	16-103	HOSE, FUEL 5/16 30R9 FUEL INJECTION
QTY	ITEM	PART NO.	DESCRIPTION

SECTION FIVE: PARTS LISTING AND REFERENCE

DECALS



44-084, DECAL, CAUTION HOT SURFACE

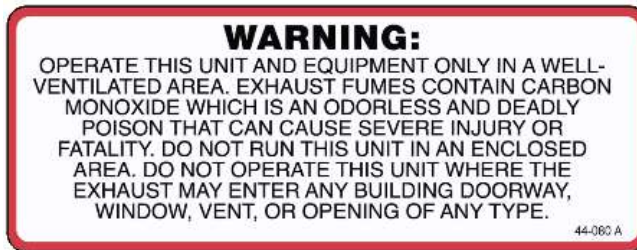

44-080, DECAL, WARNING USE IN WELL VENTILATED AREA

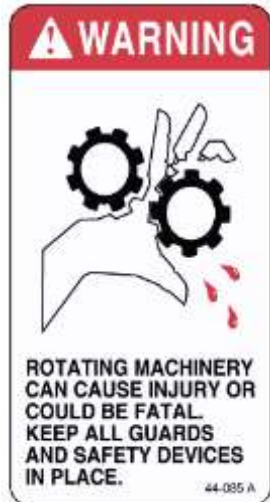

44-085, DECAL, WARNING ROTATING MACHINERY

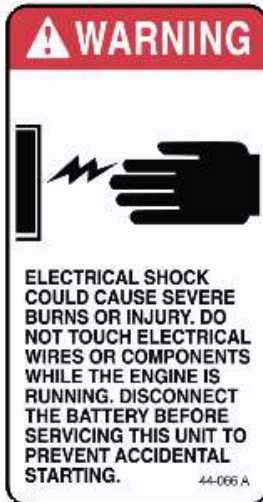

44-066, DECAL, WARNING ELECTRIC SHOCK



44-067, DECAL, WARNING READ MANUAL



44-090, DECAL, WARNING MANIFOLD MAINTENANCE



44-079, DECAL, UNLEADED FUEL ONLY



44-312, DECAL, 500 EMBLEM

SECTION FIVE: PARTS LISTING AND REFERENCE

PEAK 500 WIRING DIAGRAM

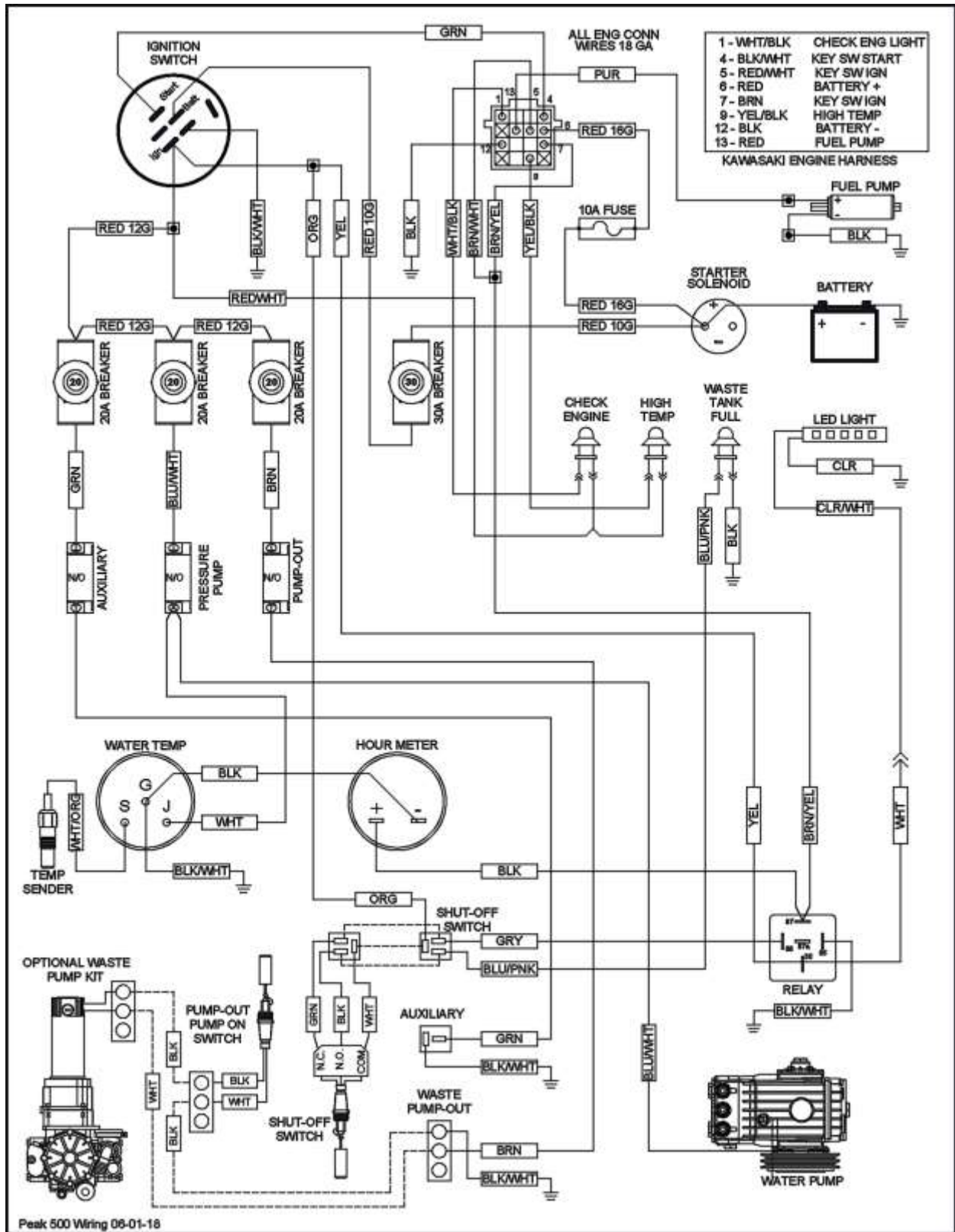

SECTION FIVE: PARTS LISTING AND REFERENCE
PEAK 500 HOSE ROUTING AND FLOW DIAGRAM

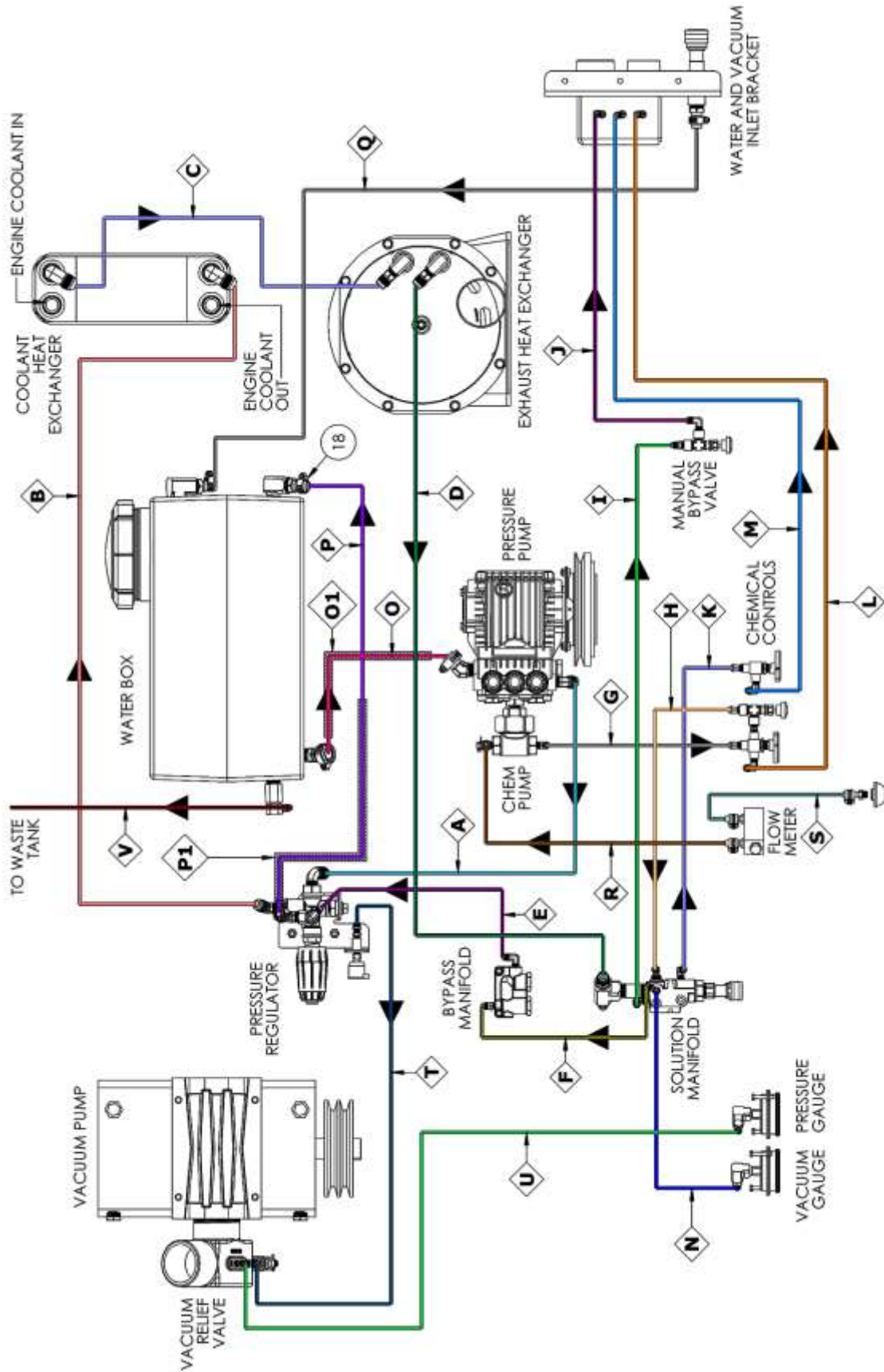

SECTION FIVE: PARTS LISTING AND REFERENCE

HOSE IDENTIFICATION CHART (SEE HOSE ROUTING DIAGRAM)

HOSE LENGTHS			
ID	PART NO. (HOSE ID)	LENGTH (IN)	CLAMPS
A	18-214-03 (7/16)	15	N/A
B	18-214-14 (7/16)	20	N/A
C	18-214-05 (7/16)	24	N/A
D	18-214-14 (7/16)	20	N/A
E	18-215-08 (3/16)	15.5	N/A
F	18-215-04 (3/16)	10	N/A
G	18-215-21 (3/16)	28	N/A
H	18-215-13 (3/16)	24	N/A
I	18-215-33 (3/16)	36	N/A
J	18-215-13 (3/16)	24	N/A
K	18-215-33 (3/16)	36	N/A
L	18-215-33 (3/16)	36	N/A
M	18-215-13 (3/16)	24	N/A
N	18-215-13 (3/16)	24	N/A
O	16-004 (3/4)	36	14-000 X2
O1	16-027	36	N/A
P	16-005 (5/8)	45	14-012 X1
P1	16-028	30	N/A
Q	16-005 (5/8)	48	14-012 X1
R	16-006 (5/16)	42	14-007 X2
S	16-006 (5/16)	60	14-007 X2
T	16-017 (1/4)	46	N/A
U	16-017 (1/4)	56	N/A
V	18-215-33 (3/16)	36	N/A

SECTION FIVE: PARTS LISTING AND REFERENCE

1992 TO 2002 FORD FUEL LINE INSTALLATION

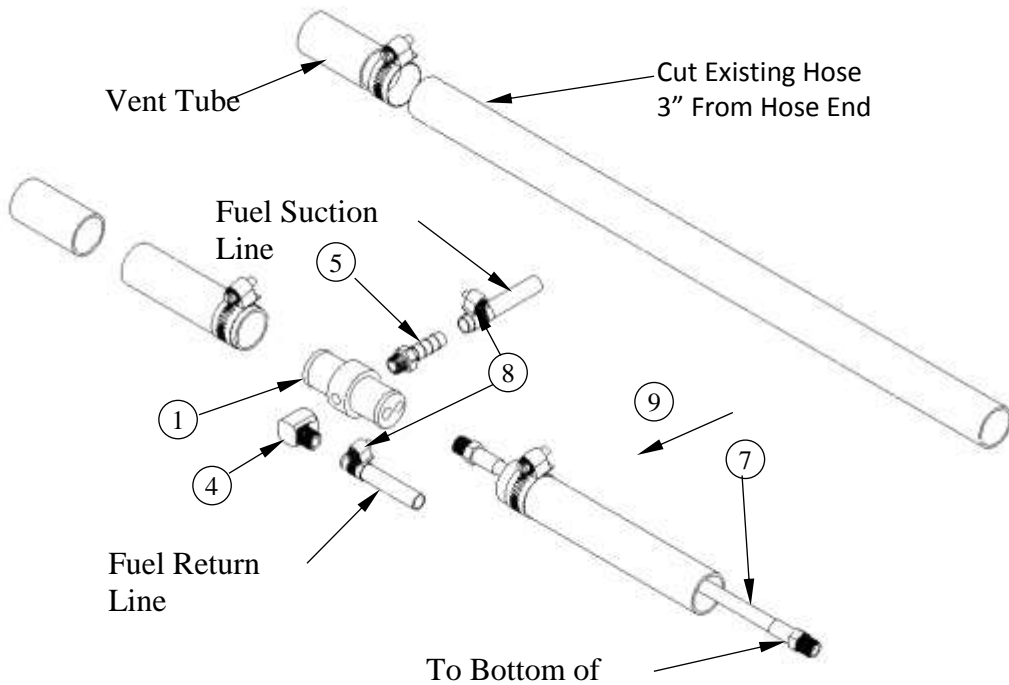

69-005FI KIT, FUEL HOOKUP FORD FI

Item No.	Part Number	Qty	Description
1	66-031	1	ADAPTOR, VENT TUBE(FORD)
2	21-086	2	FTTG, BULKHEAD 1/4 IN BRASS
3	21-039	2	ELL, 1/4 IN LG STREET BRASS
4	21-038	1	ELL, STREET 1/8 IN BRASS
5	21-007	2	FTTG, BRB 1/8P X 5/16 H BR
6	21-006	4	FTTG, BRB 1/4P X 5//16H BR
7	18-028	1	HOSE, 3/16 X 25 (1/8P X 1/8P NO COVER)
8	14-011	6	CLAMP, HOSE FUEL # 6
9	14-000	2	CLAMP, HOSE #12

SECTION FIVE: PARTS LISTING AND REFERENCE
CHEVY AND GMC FULL SIZE VAN FUEL LINE INSTALLATION

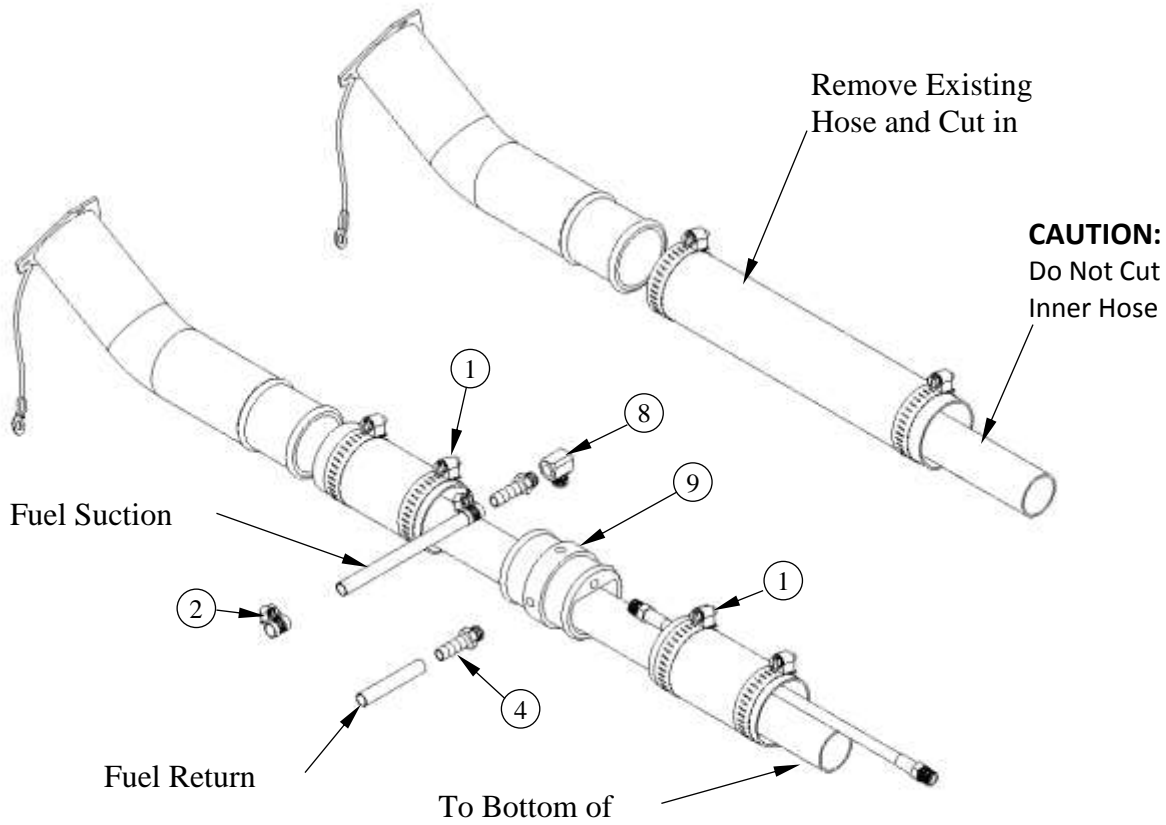

69-003FI KIT, FUEL HOOKUP 97 & 2002 FI

Item No.	Part Number	Qty	Description
1	14-010	2	CLAMP, HOSE # 32
2	14-011	6	CLAMP, HOSE FUEL # 6
3	21-006	4	FTTG, BRB 1/4P X 5//16H BR
4	21-007	2	FTTG, BRB 1/8P X 5/16 H BR
5	21-038	1	ELL, STREET 1/8 IN BRASS
6	21-039	2	ELL,1/4 IN LG STREET BRASS
7	21-086	2	FTTG, BULKHEAD 1/4 IN BRASS
8	21-116	1	ELL, 1/8 FP X 1/8 FP BRONZE
9	66-030	1	ADAPTOR,FUEL NECK(CHEVY)
10	18-027	2	HOSE, 3/16 X 5 (1/8P X 1/8P NO CVR)

SECTION FIVE: PARTS LISTING AND REFERENCE
2003 CHEVY AND GMC FULL SIZE VAN FUEL LINE INSTALLATION

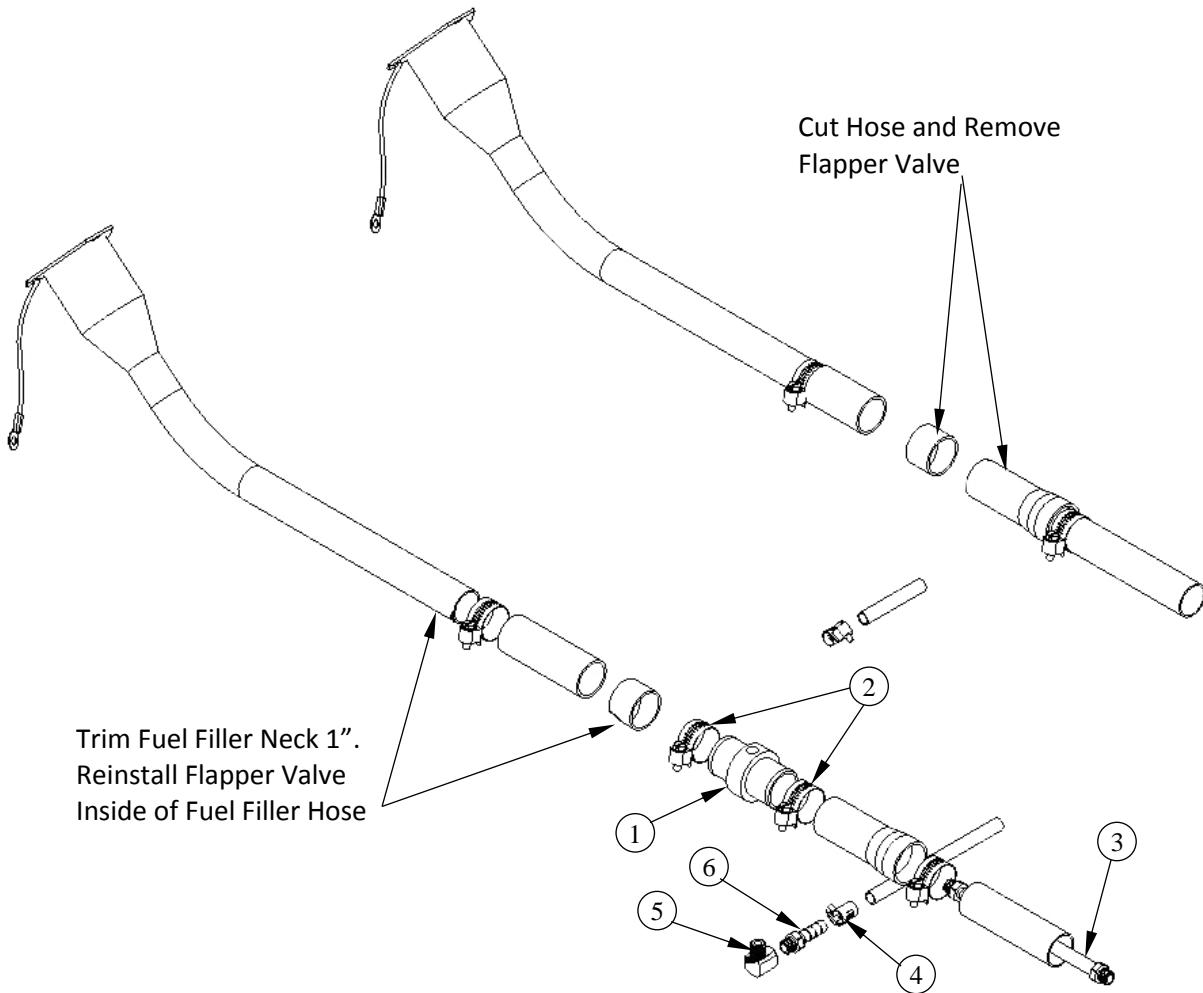

69-018FI KIT, FUEL HOOKUP 2003 CHEVY FI

Item No.	Part Number	Qty	Description
1	66-034	1	ADAPTOR, FUEL FLR CHVY 2003
2	14-006	2	CLAMP, HOSE # 20
3	18-028	1	HOSE, 3/16 X 25 (1/8P X 1/8P NO COVER)
4	14-011	6	CLAMP, HOSE FUEL # 6
5	21-038	1	ELL, STREET 1/8 IN BRASS
6	21-007	2	FTTG, BRB 1/8P X 5/16 H BR
7	21-039	2	ELL, 1/4 IN LG STREET BRASS
8	21-006	4	FTTG, BRB 1/4P X 5//16H BR
9	21-086	2	FTTG, BULKHEAD 1/4 IN BRASS

SECTION FIVE: PARTS LISTING AND REFERENCE
1997-2002 DODGE FULL SIZE VAN FUEL LINE INSTALLATION

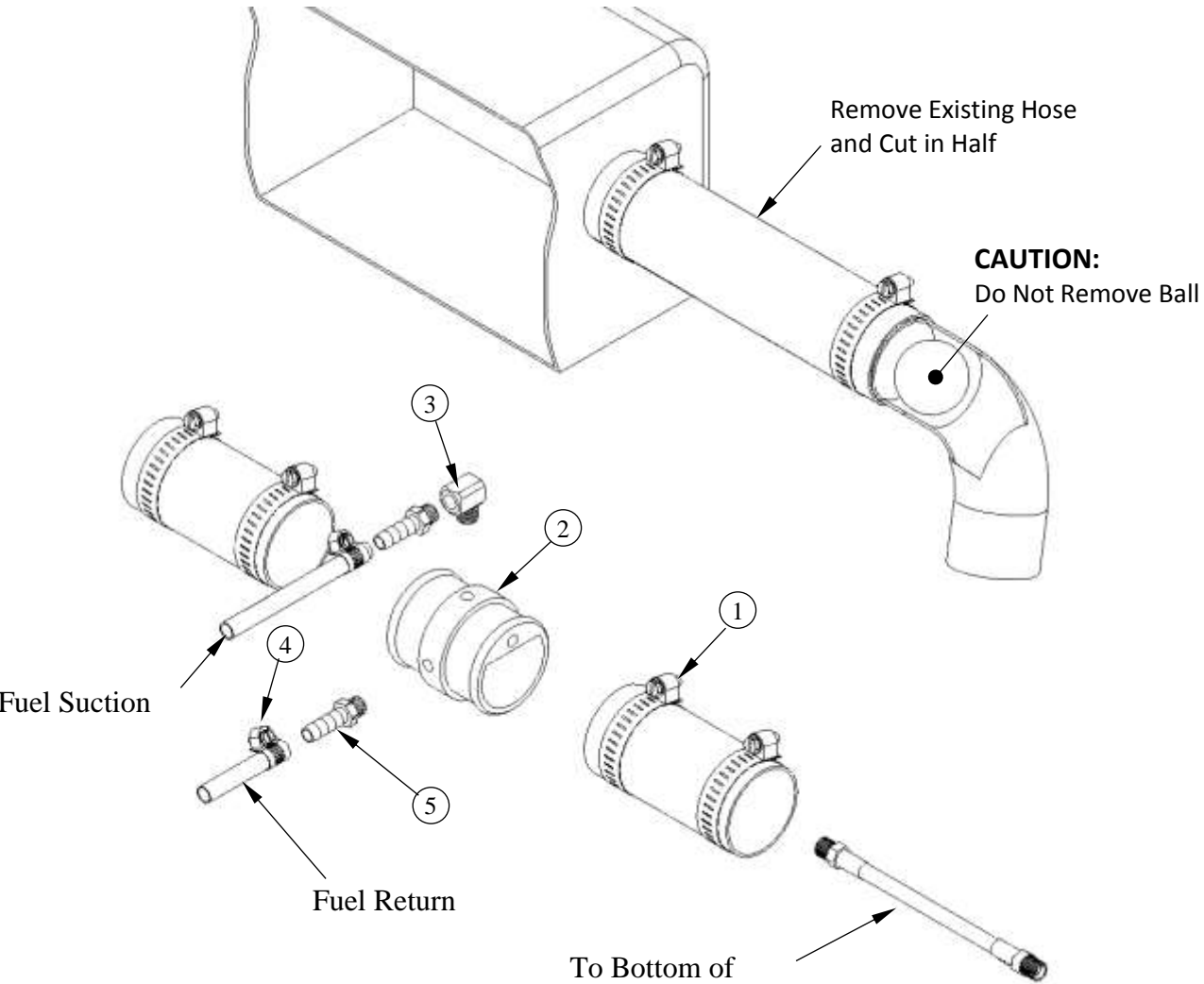

69-004FI KIT, FUEL HOOKUP CHEVY/DODGE FI

Item No.	Part Number	Qty	Description
1	14-010	2	CLAMP, HOSE # 32
2	66-030	1	ADAPTOR,FUEL NECK(CHEVY)
3	21-038	1	ELL, STREET 1/8 IN BRASS
4	14-011	6	CLAMP, HOSE FUEL # 6
5	21-007	2	FTTG, BRB 1/8P X 5/16 H BR
6	18-028	1	HOSE, 3/16 X 25 (1/8P X 1/8P NO COVER)
7	21-086	2	FTTG, BULKHEAD 1/4 IN BRASS
8	21-006	4	FTTG, BRB 1/4P X 5//16H BR
9	21-039	2	ELL,1/4 IN LG STREET BRASS