

PROCHEM®

SAFETY, OPERATION & MAINTENANCE INSTRUCTIONS

POWERMATE AC1204



- **CAUTION-READ THE INSTRUCTION MANUAL BEFORE USING THE APPLIANCE.**
- **ORIGINAL INSTRUCTIONS**
- **MANUAL ALSO AVAILABLE ON-LINE AT WWW.PROCHEM.CO.UK**

MACHINE DATA

MODEL NO.	AC1204
SERIAL NO.	
DATE OF PURCHASE	
DISTRIBUTOR NAME	
DISTRIBUTOR TEL NO.	
MANUFACTURER CONTACT	Prochem Europe Ltd. Oakcroft Road, Chessington, Surrey KT9 1RH, UK Telephone: + 44 (0)20 8974 1515 Fax: + 44 (0)20 8974 1511 Email: sales@prochem.co.uk Website: www.prochem-uk.com

All information and specifications in this manual are current at the date of issue. However, because of Prochem Europe's policy of continual product improvement, we reserve the right to make changes at any time without notice. Please note that this manual applies to all models and explains variations including accessories used. Therefore, you may find some explanations for variations and options not installed on your equipment.

CONTENTS

	PAGE NO.
WARRANTY	5
WARNING SECTION	6
IMPORTANT SAFETY INSTRUCTIONS	7
GENERAL DESCRIPTION OF APPLIANCE & IMPORTANT OPERATING INSTRUCTIONS	8
GENERAL OPERATING INSTRUCTIONS	9
GENERAL MAINTENANCE	11
GENERAL FAULT FINDING	12
PARTS DIAGRAM	13
PARTS LIST	14
PARTS DIAGRAM	15
PARTS LIST	16
WIRING DIAGRAMS	17
DECLARATION OF CONFORMITY	18



This product is marked according to the **European Directive (2002/96/EC) on Waste Electrical and Electronic Equipment (WEEE)**.

The symbol on this product indicates that this product must not be disposed of with normal household waste. Please protect human health and the environment by disposing of this product responsibly in the correct manner.

For further information regarding the disposal, treatment, recycling and recovery of this product, please contact:

Prochem Europe Sales Department
Telephone: +44 (0)20 8974 1515

Prochem Europe Ltd. EEE Producer Registration Number: WEE / AJ0044SY

European Directive (2015/863/EU) Restriction of use of certain Hazardous Substances in Electrical and Electronic Equipment (RoHS2).

This equipment does not contain more than the maximum permitted levels by weight of the following substances:
Lead (Pb), Mercury (Hg), Cadmium (Cd), Hexavalent Chromium (Cr (VI)),
Polybrominated Biphenyls (PBB), Polybrominated Diphenyl Ethers (PBDE)



MACHINE WARRANTY

DATE EFFECTIVE: 1/7/15

As of the above date, this warranty supersedes all previous warranties and forms part of the contract of sale. Prochem Europe Ltd. (hereafter referred to as "Prochem") guarantees this machine to be free from defects in materials and workmanship for the relevant time period as shown below, and from the actual date of purchase by the user. Proof of the purchase date from a Prochem Authorised Distributor will be required for performance of this warranty.

Rotationally moulded polyethylene tanks2 Years
All other parts except maintenance items (see below)1 Year

THIS WARRANTY EXCLUDES NORMAL MAINTENANCE ITEMS, including but not limited to HOSES, FILTERS, O-RINGS, DIAPHRAGMS, VALVES, DRIVE BELTS, GASKETS, CARBON BRUSHES and damage to motors and other components as a result of failure to replace normal maintenance items. THIS LIST IS NOT EXHAUSTIVE.

To obtain performance of this warranty, contact the Prochem Authorised Distributor who supplied the product.

The Prochem Authorised Distributor is responsible as the selling agent for the provision of initial training in the correct use and application of the machine and approved chemicals. The distributor is also responsible for service maintenance and repairs during and after the warranty period and the administration of any warranty claims in conjunction with the Prochem Service Department. Failure of any of these provisions and responsibilities may invalidate the warranty and the authorised status of the distributor.

If Prochem receives notice of any defects during the warranty period, Prochem reserves the right to either repair, or replace components that prove to be defective. Goods must be returned before the warranty is approved. Goods sent out prior to the return of faulty items will be invoiced at current prices, subject to standard payment terms (see Prochem Standard Terms and Conditions of Sale). Replacement parts supplied under warranty will be guaranteed for the remainder of the original machine warranty and **NOT** from the date of installation. Spare parts supplied after expiry of machine warranty may be covered by a manufacturer's warranty, subject to inspection by Prochem Europe Ltd. and at its sole discretion. Normal maintenance items, however, are not covered. Replacement or credit of any returned parts will be at the discretion of the Prochem Service Department. Any subsequent refusal to accept their decision will serve to invalidate this warranty with immediate effect.

PROCHEM AUTHORISED DISTRIBUTORS are responsible for machine and accessories service back up during and after the warranty period. Prochem will furnish parts if the warranty is approved, but **DISTRIBUTORS** will be responsible for fitting, service, labour and related charges including travel, if applicable, and the cost of returning the machine or parts to Prochem. If any chargeable work is undertaken by Prochem for **DISTRIBUTORS** the labour, parts (if applicable) and return carriage will be charged at **FULL LIST PRICE**. If warranty is approved due to genuine manufacturing defect, then labour charges and carriage charges may be waived at Prochem's discretion.

Prochem may send replacement parts to customers supplied by a **DISTRIBUTOR** or directly by Prochem, subject to the same conditions of replacement and payment above. The customer, however, will be responsible for fitting, labour and the carriage costs of returning repaired parts. Alternatively, Prochem will undertake warranty work at Chessington, subject to the same conditions, but the customer will be responsible for all carriage charges.

Any of the following circumstances involving the machine will serve to invalidate this warranty:-
NORMAL WEAR, ACCIDENTS, USE OF THE MACHINE FOR A PURPOSE OTHER THAN THAT FOR WHICH IT WAS INTENDED, INCORRECT MAINTENANCE, THE USE OF CHEMICALS OTHER THAN THOSE SUPPLIED OR APPROVED BY PROCHEM, INCORRECT INSUFFICIENT OR NON-USE OF DEFOAMER, EXPOSURE TO EXTREME TEMPERATURES OR CONDITIONS, INCORRECT INSTALLATION OR REPAIR & UNAUTHORISED INTERVENTION.

Liability is excluded for the following: -
All forms of damage and special damage founded in tort (apart from death and personal injury) and contract law including but not limited to consequential loss, loss of income and losses incurred in reliance of the contract; service, labour or third-party charges and the cost of returning the machine or defective parts to Prochem or Prochem's Authorised Distributor.
As against a person dealing as a consumer, this warranty creates specific rights in addition to any statutory rights, which are unaffected. As against a person dealing otherwise than as a consumer, however, this warranty excludes any implied term that the machine will correspond with a description or a product sample.
With the exception of some specific products which are labelled and intended to be used by a consumer, all equipment, machinery, accessories, products, services and advice supplied by Prochem is intended for professional and industrial use only.

Your Prochem unit is designed to give you many years of reliable service. If a problem should arise during or after the warranty period, contact the Prochem Authorised Distributor or the Prochem Service Department, for details of the services available. Only the original purchaser of the new equipment may seek performance of this warranty – these rights cannot be transferred to a third party.

Prochem Europe Ltd.
Oakcroft Road, Chessington, Surrey KT9 1RH, ENGLAND
Telephone: + 44 (0)20 8974 1515 Fax: + 44 (0)20 8974 1511

Machine Warranty Issue 10 1/7/15

WARNINGS!

- **Warning!**
Machines shall not be used by children. Children should be supervised to ensure that they do not play with the appliance. This machine can be used by people with reduced physical, sensory or mental capabilities or lack of experience and knowledge if they have been given supervision or instruction concerning the use of the machine in a safe way and understand the hazards involved.
- **Caution:** this machine is for indoor use only.
- **Caution:** this machine shall be stored indoors only.
- **Warning!**
This machine must be disconnected from the mains during cleaning or maintenance, when replacing any parts or converting the machine to another function.
- **Caution:** under no circumstances should the machine be carried by or bumped up a flight of stairs using the handle.

IMPORTANT SAFETY INSTRUCTIONS

**PLEASE READ THE FOLLOWING IMPORTANT SAFETY INSTRUCTIONS (!!)
BEFORE ATTEMPTING TO USE THIS MACHINE. FAILURE TO OBSERVE THE
INSTRUCTIONS MAY RESULT IN PERSONAL INJURY.**

!! CAUTION

Read the instruction manual before using the appliance.

!! SOUND PRESSURE LEVEL

The sound pressure of this machine, when in use, does not exceed 85 dB (A).

!! APPLIANCE SUITABILITY

This appliance is suitable for commercial use, for example, in hotels, schools, hospitals, factories, shops, offices and rental businesses.

!! FOR MAINS POWERED APPLIANCES during cleaning and maintenance – the plug is to be removed from the outlet socket.

!! TRAINING

You must be trained in the operation of this machine before use. Please read this manual carefully and obtain operating instruction from your Prochem Distributor or authorised representative in the correct use of this equipment and suitable chemicals before attempting to clean.

!! REPAIRS

Should any repairs, including supply cord replacement be required, we recommend that the appliance be returned to an authorised dealer.

!! ELECTRICAL CABLE INSPECTION & REPLACEMENT

This machine must be earthed while in use to protect the operator from electric shock. It is equipped with a sealed and approved EC three conductor cable and three-prong 13A plug. If the supply cord is damaged it must be replaced by a special cord or assembly available from the manufacturer or its service agent. During operation a hazard may occur when running the machine over the power supply cord. The power supply cord should be regularly inspected for signs of damage. If the power supply cord is damaged, it must be replaced.

!! RCD CIRCUIT BREAKER

In common with other household and commercial electrical equipment, an 'RCD' circuit breaker plug device is strongly recommended for this type of equipment.

!! EXTENSION CABLES

Avoid using extension cables with this machine. If an extension cable is used it should be of a suitable rating and no longer than 30 metres. Use only three wire CE approved extension cable with CE approved three-prong earthed plugs and three pole receptacles that accept the machine 13 amp plug.

!! DO NOT use a multiple adaptor socket to connect the machine and heating units or other devices to a single extension cable.

!! DO NOT stand the machine in water to operate such as during flood extraction.

SERIOUS INJURY OR DEATH MAY RESULT IF MACHINE IS IMMERSSED IN WATER!

!! DO NOT pull the machine by the power cable or hoses.

!! DO NOT use this machine with or near flammable vapours. These machines can ignite flammable vapours such as fuels, solvents or thinners.

!! DO NOT operate the machine unless it is completely assembled.

!! DO NOT attempt repairs or maintenance unless you are suitably qualified or experienced. Repairs and maintenance should only be performed by qualified personnel and the machine should be tested for electrical safety before re-use.

!! SPRAY LIQUID ejection could be hazardous as a result of its temperature, pressure or chemical content.

!! ALWAYS disconnect machine from mains supply when left unattended when cleaning the appliance.

GENERAL DESCRIPTION OF APPLIANCE

The AC1024 Powermate is an accessory for use with Hot Water Extraction Carpet Cleaning machines.

It has a mains electricity supplied motor driven rotary brush and a spray tip.

The unit attaches by a high-pressure solution hose and vacuum suction hose to the main machine and to the mains electricity outlet via a power cord.

IMPORTANT OPERATING INSTRUCTIONS

PLEASE READ THE FOLLOWING IMPORTANT OPERATING INSTRUCTIONS (!) BEFORE ATTEMPTING TO USE THIS MACHINE. FAILURE TO OBSERVE THE INSTRUCTIONS MAY RESULT IN DAMAGE TO THE EQUIPMENT.

! DO NOT expose the machine to rain or freezing temperatures. Drain solution system and store indoors when not in use.

! DO NOT operate the machine without solution and waste tank filters.

! DO NOT use boiling water or temperature in excess of 76°C.

! DO NOT use chemicals in the machine other than those manufactured or recommended by Prochem Europe.

! DO NOT use the machine for dry vacuuming. The vacuum must only be used for wet extraction in conjunction with the spray system.

! DO NOT run the solution pump and/or heating unit dry. Always switch off and disconnect the machine and/or heating unit electrical supply when re-filling with solution.

! ALWAYS use a clean bucket to fill the solution tank.

! AFTER USE flush solution system and rinse the waste tank with clean water and remove loose fibres from the vacuum filter.

! ALWAYS observe directions and safety precautions on chemical products.

! ALWAYS pre-test carpet or fabric for colour fastness and suitability with ready-to-use cleaning solution before proceeding.

! ALWAYS use defoamer in the waste tank to control foaming from previous shampoo residues in the carpet.

! IF POWDERED CHEMICALS are used, always premix in a separate bucket before adding to solution tank. If not properly dissolved, powdered cleaning solution may result in damage to the solution pump.

! USE ONLY genuine replacement parts for this machine, supplied by an authorised Prochem Distributor.

! DO NOT use this machine for any purpose other than for its intended design function. Any deviation from its proper use or purpose and any consequential **damage** that may occur is the sole responsibility of the user.

! ALWAYS discharge soiled solution to a sewage drain linked to a sewage treatment facility.

! DO NOT discharge soiled solution into roadside storm drains.

! DO NOT use the drain valve to lift the machine which may result in damage to the drain valve or leakage from the drain valve mounting.

GENERAL OPERATING INSTRUCTIONS

UNPACKING YOUR NEW AC1204 POWERMATE:

When your package is delivered, check the carton carefully for signs of rough handling. If your AC1024 is damaged, notify the carrier immediately and request an inspection. Be sure to keep the carton, packing inserts, packing lists and carrier's receipt until the inspector has verified your claim.

PROCHEMS liability ceases when the carrier picks up the shipment. However, our customer service staff will be happy to furnish any information needed in connection with the claim and will attempt to expedite a resolution.

PLEASE READ BEFORE OPERATING YOUR NEW AC1204 POWERMATE:

Read the manual carefully and completely before attempting to operate the unit. This manual has important information for the use and safe operation of the machine. Keep this manual handy at all times.

This equipment has been engineered and manufactured to provide excellent performance and service.

To ensure that your equipment will continue to perform as intended:

Maintain equipment regularly- following the suggested maintenance schedule provided.

Use only original PROCHEM parts when servicing.

Operate equipment with care.

If additional information is needed, please contact:

PROCHEM 0208 974 1515

All information and specifications printed in the manual are current at the time of printing; however, because of PROCHEMS policy of continual product development, we reserve the right to make changes at any time without notice.

Preparing the AC1024 POWERMATE for Use.

Set up your extraction machine ensuring that the machine has solution in the solution tank and the waste tank is empty and defoamer has been drawn through the vacuum hose.

1. Attach the solution hose to the Powermate via the female quick connect on the handle.
2. Attach the 1 1/2 in cuff of the vacuum hose onto the Powermate tube handle.
3. Ensuring that the power switch of the Powermate is in the off position plug the power cord into the 13A mains supply.

Operating the AC1204 POWERMATE.

The Powermate is now ready for use.

1. Switch on the pump and vacuums of the main parent machine.
2. Switch on the Powermate the green switch should illuminate.
3. You can now squeeze the trigger on the solution valve and use the Powermate to agitate the solution in the carpet fibre and vacuum up the used waste solution.

Practical use of the AC1204 POWERMATE

Once the above instructions have been carried out the Powermate must be operated in the following manner.

1. Tilt back the AC1204 so that the brush is clear of the carpet and push the unit forward to full extent of arm movement.
2. Tilt the AC1204 forward until the brush contacts the carpet.
3. Tilting the unit to maintain contact squeeze the solution valve trigger and pull the unit towards you.
4. This is the end of the cleaning stroke you should notice waste solution being drawn through the front clear suction cover.
5. **Under no circumstances should the AC1204 be pushed forward with the brush in contact with the surface being cleaned, this action will result in the machine being damaged.**

Packing up the AC1204 POWERMATE after use.

When the cleaning task is finished.

1. Switch off the Powermate the switch illumination will extinguish and the brush will stop turning.
2. Remove the plug from the mains outlet.
3. Flush the Powermate with clean water when you flush the pump system on the parent machine.
4. Disconnect the solution line and release any pressure in the Powermate by depressing the solution valve trigger.
5. Recover the power cord and wind around the cord wrap hooks for safe storage.

Storage of the AC1204 POWERMATE

The AC1204 Powermate must be stored indoors in a clean warm environment.

1. If you expose the AC1204 to freezing conditions it will result in serious damage to the unit.
2. If you expose the AC1204 to rain or a flooded environment you will cause serious damage to the unit and could in certain circumstances cause injury to the operator.

GENERAL MAINTENANCE

MAINTENANCE:

This AC1204 has been engineered and built to require minimum maintenance. But like any machine, it does require some care to keep it in optimum working condition. Careful attention to these maintenance instructions will give you maximum operating performance and life expectancy of the machine.

CAUTION: Disconnect the power cord from the outlet before doing any clean up or maintenance on the machine.

DAILY MAINTENANCE:

Some maintenance of the AC1204 Powermate will be required.

1. Flush solution line with clean water by filling the solution tank of the parent machine and spraying.
2. Keep the exterior of the Powermate free from dust and debris by wiping it down with a cloth.
3. Inspect the Power Cord for damage, do not use the Powermate with a damaged power cord.
4. Remove any hair or debris from the rotating brush.
5. Check the spray tip for any debris and clean if necessary.
6. Check security of all nuts and screws paying particular attention to the trigger valve hanger.

DO NOT ATTEMPT REPAIR

INSTRUCTION FOR THE REPLACEMENT OF POWER CORD WITH COMBINED PLUG (ALL MACHINES)

!!Caution – only qualified maintenance personnel should attempt the following repair

Should the power cord require replacement please follow the instructions below.

1. The replacement cord and plug shall be of the same specification as the original, Prochem part number BE4901(3 core, 1.5mm with 13Amp sealed plug unit)
2. Ensure that the machine is disconnected from the electrical supply and open the electrical housing by means of the tool required.
3. Disconnect the live (brown), neutral (blue) and earth (green/yellow) wires from the cable terminal block by unscrewing the terminal block clamp wire screws.
4. Release the outer cable clamp next to the terminal block by unscrewing the two securing screws, then unscrew the outer cable gland to release the cable which can then be pulled out of the cable gland assembly.
5. Insert the new cable through the gland, then secure and clamp the outer cable by means of tightening the outer gland and the two securing screws next to the terminal block.
6. Connect the live (brown), neutral (blue) and earth (yellow/green) to the cable terminal block ensuring that the earth strand is longer than the live and neutral strand as follows.
The conductor of the wire coloured brown shall be connected to the terminal marked (L), the conductor of the wire coloured blue shall be connected to the terminal marked (N) and the conductor of the wire coloured yellow and green shall be connected to the terminal marked with the earth symbol.
7. Ensure that all connections are secure, close the machine electrical housing and secure with the tool required.
8. A Portable Appliance Test (PAT) should now be carried out.

GENERAL FAULT-FINDING GUIDE

NO POWER

With the unit plugged into the mains outlet and the brush motor switched to on.

PROBABLE CAUSES

Defective power cord
Blown plug fuse
House or Building circuit breaker tripped

CORRECTIVE ACTION

Replace Power Cord
Replace fuse
Reset breaker switch.

NO OR MINIMAL SPRAY

With solution hose connected, parent machine pump on and functioning correctly, trigger valve squeezed.

PROBABLE CAUSES

Parent machine pump inoperative or defective
Spray tip blocked
Blockage in solution line
Defective Trigger Valve Assembly
Damaged solution hose connectors

CORRECTIVE ACTION

Repair pump
Clean spray tip
Clear blockage
Repair or replace trigger valve Assembly
Replace solution hose connectors

NO OR MINIMAL VACUUM

With vacuum hose connected to parent machine and vacuum switched on and functioning correctly.

PROBABLE CAUSES

Damaged suction cover
Glide missing or defective
Damaged vacuum hose
Blocked vacuum hose and tube

CORRECTIVE ACTION

Replace suction cover
Replace glide
Replace vacuum hose
Remove blockage.

NO BRUSH ACTION

With unit connected to the mains and brush switch in the on position.

PROBABLE CAUSES

Same as no power
Defective switch
Broken drive belt
Defective motor

CORRECTIVE ACTION

Same as no power
Replace switch.
Replace drive belt
Replace motor

POWERMATE 1204ACH

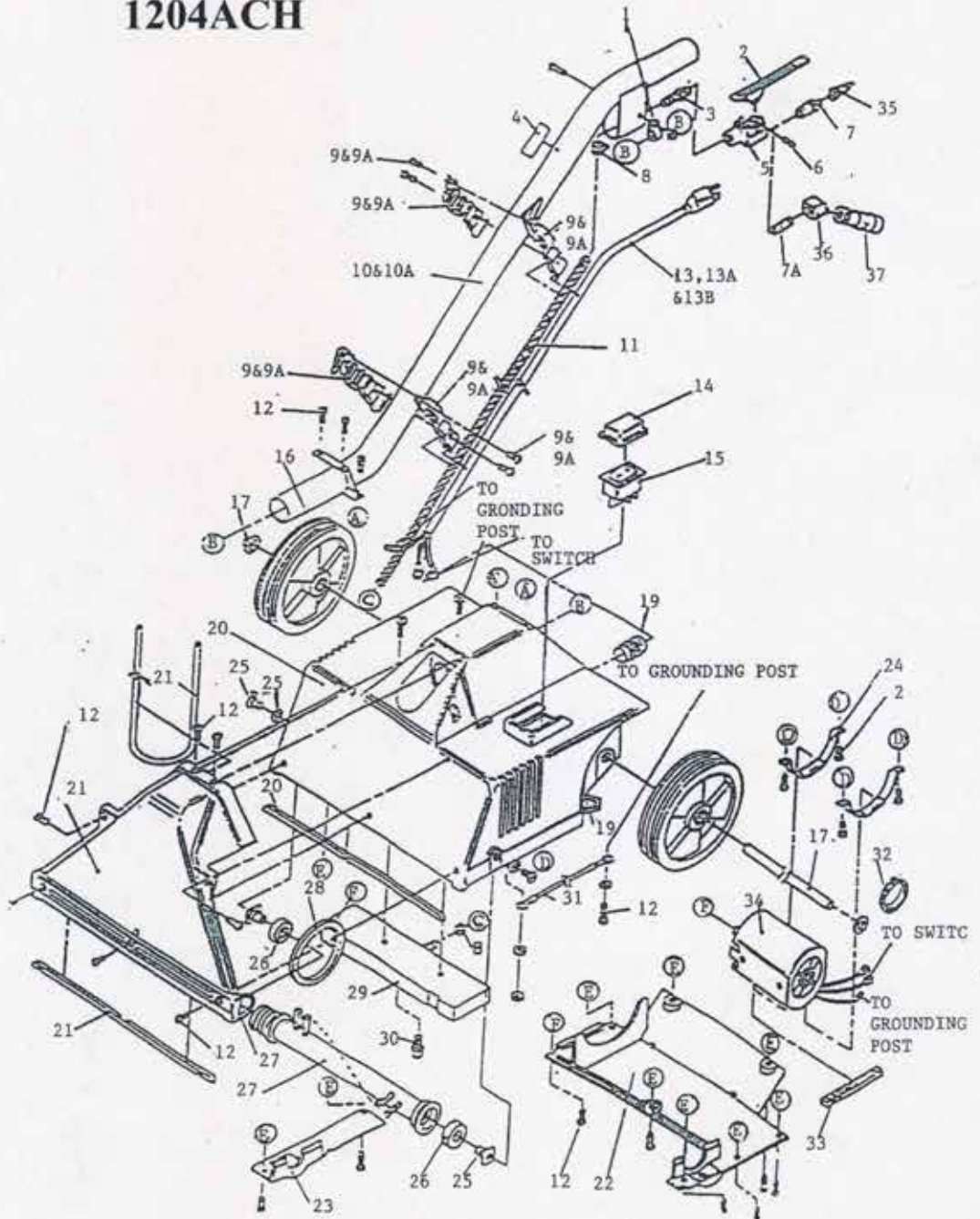

1204ACH-1.jpg

PARTS LIST

ITEM	STOCK CODE	PART NUMBER	DESCRIPTION	QTY
1	E02200	B02200	CABLE CLAMP	1
2		D00352-3	LEVER VALVE	1
3		A00065P	¼ BARB X ¼ MP NYLON	1
4		H00564-2	WARNING LABEL TO AVOID ELECTRIC SHOCK	1
5	E00525	G00525	PH VALVE	1
6		C00303	1/8 X ¾ TUBULAR PIVOT	
7	E00095-1	A00168-18	BUSH ¼ - 1/8	1
8		J00651	SCREW CLAMP ¼ HOSE	1
9	E02494-1A	02494-1A	CORD HOOK SET 1 1/4	1
10		D02382	HANDLE, ONE PIECE	1
11		J00596	¼ BRAIDED HOSE	4
12		C00310-38	8-32 X 3/8 RH MACHINE BLACK PHILLIPS SS	25
13	BE4901		POWER CORD	1
14	E00214-2	B00214-2	COVER, SWITCH, ROCKER	1
15	E02211-1	B02211-1	SWITCH ILLUM GREEN 240V	1
16		G02531-1	WHEEL, 4.25 X 3/8	2
17		82331-2A	AXLE ASSY	1
18		C00312-1	10-32 X 1 1/8 TRUSS HEAD BLACK ZINC	2
19		B02212	LIQUID TIGHT STRAIN 3/8 NPT WITH NUT	1
20		82490A	MOTOR HOUSING ASSY	1
21	E82491A	82491A	SUCTION HEAD LENS	1
22		F02492	BOTTOM COVER	1
23		F02493	BELT ACCESS COVER	1
24		82363A	MOTOR STRAP ASSY	2
25	E82424A	82424A	BEARING SHAFT ASSY	1
26		G00528-3	BRUSH BEARING	2
27	E80508-1A	80508-1A	BRUSH ASSY	1
28	E02445	E02445	MOTOR BELT	1
29		D00356-4	WEIGHT BLOCK	1
30	E00091	A00091-1	SPRAY TIP 110/08 1/8 MP BRASS	1
31		00185-6A	UE WIRE ASSY	1
32		B00190	4 NYLON TIE	1
33		E03428	MOTOR SEAL GASKET	1
34		G00539	PW MOTOR	1
35	GU00102	A00102	FEMALE QC	1
36	E00053	A00053	45 ELBOW ¼ MP X ¼ FP	1
		E90001A	RFI/ EMC FILTER (Not Shown)	1

**WAND VALVE SET UP FROM
JANUARY 2018**

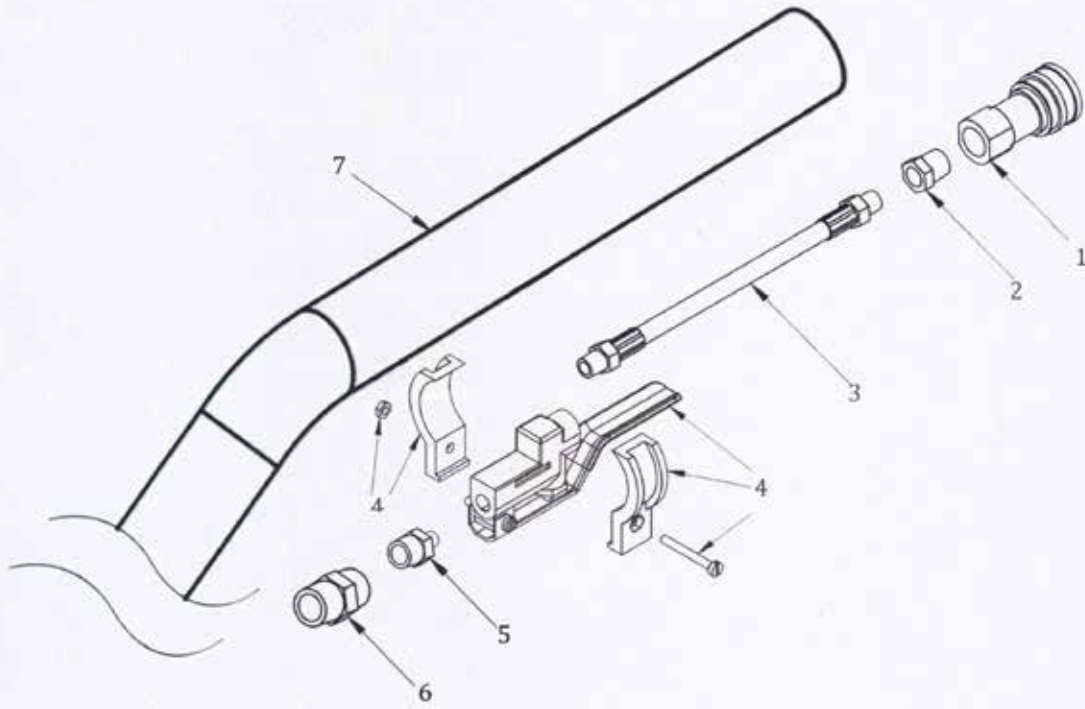

ITEM	STOCK CODE	PART NUMBER	DESCRIPTION	QTY
1	GU00102	A00102	FEMALE QC	1
2	E00095-1	A00168-18	BRASS BUSHING	1
3	E11527A	11527A-PW	1/8 HP HOSE ASSY	1
4	E11593A	G13658	VALVE WITH BRACKET	1
5	CH4018	A00114B	HEX NIPPLE 1/4MP X 1/8MP	1
6	E12964	A12964	¼ BRASS COUPLER	1
7		D02382	WAND HANDLE	1

WIRING DIAGRAM AC1204

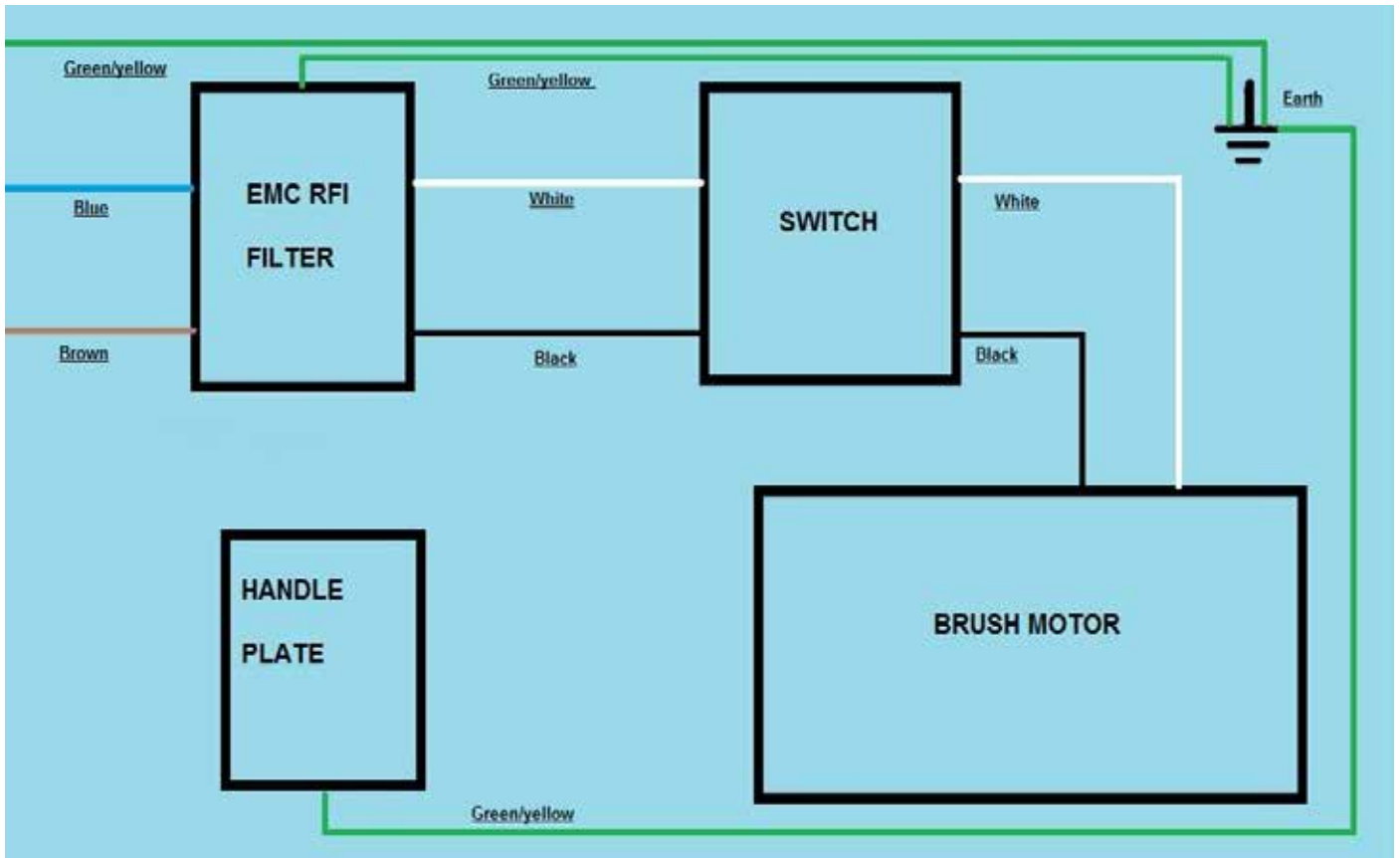

DECLARATION OF CONFORMITY

We:

Prochem Europe Ltd.,
Oakcroft Road,
Chessington,
Surrey, KT9 1RH
UK
(Importer / EC Responsible Person)

E.D.I.C
1753, Blake Avenue,
Los Angeles,
California, 90031-1006
USA
(Manufacturer)

Declare that the product(s):

Type(s): **POWERMATE**
Model(s): **AC1204**
Description: **POWER BRUSH ACCESSORY**

Has been tested to comply with the

2014/35/EU Low Voltage (LVD) Directive

A Technical file is held by Prochem Europe Ltd.

Certificate of compliance and test reports have been issued by:

Signed

(For and on behalf of the Importer / EC Responsible Person)



Name: J Hattersley
Position: Equipment Product Manager
Place of Issue: Chessington UK
Date of Issue: 29/03/2021